

MODELLING AND SIMULATION OF SOLAR PV AND WIND HYBRID POWER SYSTEM USING MATLAB/SIMULINK

Vishal Prajapati¹, Sanket Patel², Pushprajsinh Thakor³, Tejal Chaudhary⁴

¹PG Scholar, Dept. Electrical Engineering, TITS Modasa, Gujarat, India

^{2,3,4} Asst. Professor, Dept. Electrical Engineering, TITS Modasa, Gujarat, India

Abstract - Renewable energy sources have become a popular alternative electrical energy source where power generation in conventional ways is not practical. In the last few years the photovoltaic and wind power generation have been increased significantly. In this study, we proposed a hybrid energy system which combines both solar panel and wind turbine generator as an alternative for conventional source of electrical energy like thermal and hydro power generation. A simple control technique which is also cost effective has been proposed to track the operating point at which maximum power can be coerced from the PV system and wind turbine generator system under continuously changing environmental conditions. The entire hybrid system is described given along with comprehensive simulation results that discover the feasibility of the system. A software simulation model is developed in MATLAB/Simulink.

Key Words: PV System, Boost Converter, Wind Turbine, PMSG, Battery Charging

1. INTRODUCTION

Due to the critical condition of industrial fuels which include oil, gas and others, the development of renewable energy sources is continuously improving. This is the reason why renewable energy sources have become more important these days. Few other reasons include advantages like abundant availability in nature, eco-friendly and recyclable. Many renewable energy sources like solar, wind, hydro and tidal are there. Among these renewable sources solar and wind are the world's fastest growing energy sources.

1.1 Solar PV System

In 1839, a French physicist Edmund Becquerel proposed that few materials have the ability to produce electricity when exposed to sunlight.[2] But Albert Einstein explained the photoelectric effect and the nature of light in 1905. Later photoelectric effect became the basic principle for the technology of photovoltaic power generation. The first PV module was manufactured by Bell laboratories in 1954.

1.2 Wind Energy System

A wind turbine converts kinetic energy of air i.e. wind power into mechanical power i.e. rotating motion of the turbine that can be used directly to run the machine or generator. Power captured by wind turbine blade is a concomitant of the blade shape, the pitch angle, speed of rotation, radius of the rotor purposes.

2. SYSTEM CONFIGURATION

Hybrid generation systems that use more than a single power source can greatly enhance the certainty of load demands all the time. Even higher generating capacities can be achieved by hybrid system. In stand-alone system we can able to provide fluctuation free output to the load irrespective of weathers condition. To get the energy output of the PV system converted to storage energy, and constant power delivered by the wind turbine, an efficient energy storage mechanism is required, which can be realized by the battery bank.

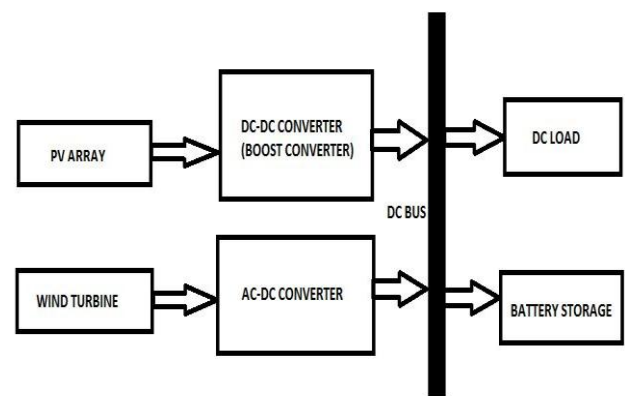

Fig.1 : Block Diagram of Hybrid System

3. DETAILED DESCRIPTION

Hybrid systems are basically an integration of solar panels and wind turbine. The output of this combination is used to charge batteries, this stored energy can be transmitted to local power stations.

3.1 Solar PV System

It contains PV modules or arrays, which convert solar energy in the form of solar irradiation into electric energy. The dc-dc converter changes the level of the voltage to match it with the electrical appliances that are supplied by this system. This DC-DC converter may be either buck or boost or buck-boost contingent on the required and available voltage levels.

The basic theory involved in working of an individual PV cell is the Photoelectric effect according to which, when a photon particle hits a PV cell, after receiving energy from sunbeam the electrons of the semiconductor get excited and hop to the conduction band from the valence band and

become free to move. Movement of electrons create positive and negative terminal and also create potential difference across these two terminals.[2]

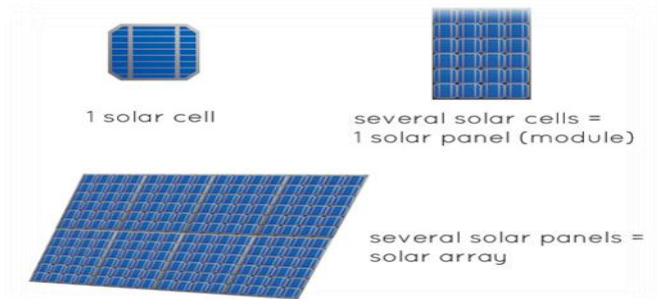

Fig: 2 PV cell, PV module and PV array [2]



Fig.5 : Horizontal Axial Wind Turbine [3]

The output of the turbine depends on the speed of the wind. The power generated by the turbine is fluctuating in the nature. In order to obtain continuous supply of power first the electricity is stored in a battery unit and then it is transferred to the load. The efficiency of wind energy system is more than solar PV system.

3.2.1 Components of Wind Turbine

The list of components which are used in wind energy system are given below :

- 1) Rotor and Rotor Blade
- 2) Hub
- 3) Main Shaft
- 4) Gearbox
- 5) Generator
- 6) Anemometer
- 7) Controller
- 8) Nacelle
- 9) Yo Motor Mechanism
- 10) Tower

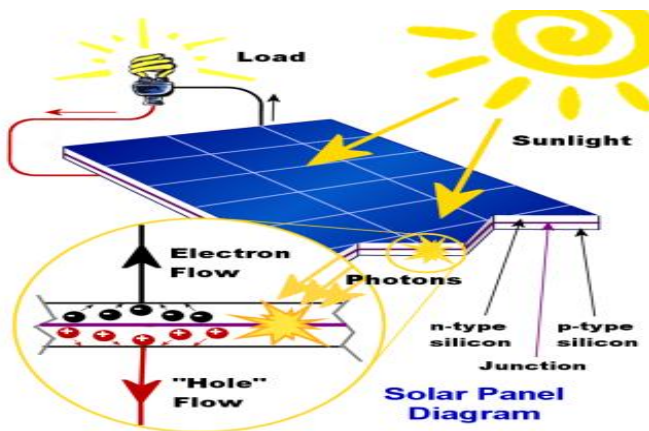

Fig.3 : Photovoltaic effect [2]

3.2 Wind Energy System

Wind is a renewable source of energy. A wind turbine is used to convert the kinetic energy of wind into electric energy. The generator connected to the shaft of the blades which converts the mechanical energy into electrical energy. There are two types of wind turbine depending upon the rotating axis of the blade, first is the vertical axis wind turbine and horizontal axis wind turbine.



Fig.4 : Vertical Axial Wind Turbine [3]

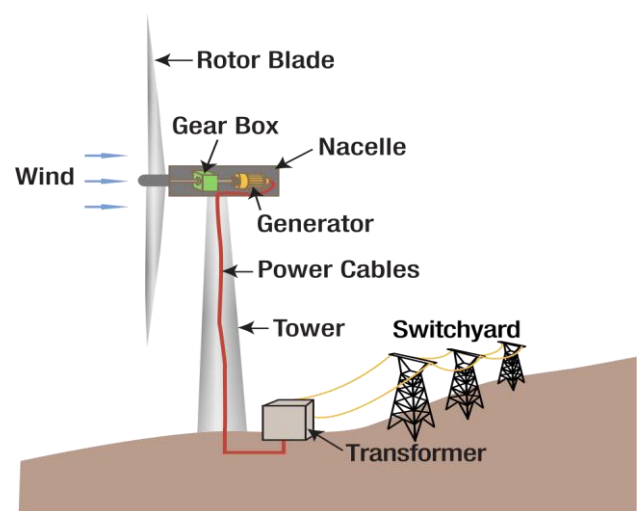

Fig.6 : Wind power diagram [5]

3.2.2 Types of Generator

Generators can be basically classified on the type of current. There are alternating current generators and direct current generators. But in either case, the voltage generated is alternating. By adding a commutator, we convert it to direct current. So for convenience, we go for alternating current generator.

In the AC generators, we can further classify them based on the rotor speed. There are synchronous generators (constant speed machine) and asynchronous generators (variable speed machine or the induction machine). Basically, a wind turbine can be equipped with any type of three-phase generator. Today, the demand for grid-compatible electric current can be met by connecting frequency converters, even if the generator supplies alternating current (AC) of variable frequency or direct current (DC).

- Asynchronous (induction) generator :
 - 1) squirrel cage induction generator (SCIG)
 - 2) wound rotor induction generator (WRIG)
 - 2.1) OptiSlip induction generator (OSIG)
 - 2.2) Doubly-fed induction generator (DFIG)
- Synchronous generator :
 - 1) wound rotor generator (WRSG)
 - 2) permanent magnet generator (PMSG)

In this project work, permanent magnet generator (PMSG) is use for wind power generation.

Permanent Magnet Generator (PMSG)

In the permanent magnet machine, the efficiency is higher than in the induction machine, as the excitation is provided without any energy supply. However, the materials used for producing permanent magnets are expensive, and they are difficult to work during manufacturing. Additionally, the use of PM excitation requires the use of a full scale power converter in order to adjust the voltage and frequency of generation to the voltage and the frequency of transmission, respectively.[7] This is an added expense. However, the benefit is that power can be generated at any speed so as to fit the current conditions.

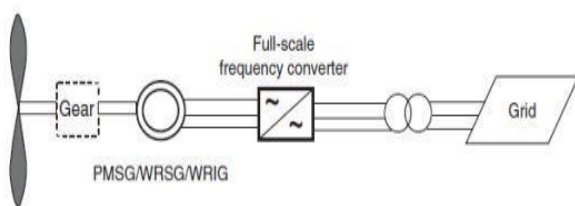

Fig.7 : Wind turbine with PMSG

The stator of PMSGs is wound, and the rotor is provided with a permanent magnet pole system. The synchronous nature of the PMSG may cause problems during startup, synchronization and voltage regulation. It does not readily provide a constant voltage. Another disadvantage of PMSGs is that the magnetic materials are sensitive to temperature. Therefore, the rotor temperature of a PMSG must be supervised and a cooling system is required.

3.3 Batteries

The batteries are used in order to store the electricity that is produced from wind and solar energy. The capacity of battery may depending on the size of wind turbine or solar power plant. Battery should be having low maintenance and charge leakage should also be low. Considering all these parameters free discharge type is the best option available.

4. SIMULATION RESULTS

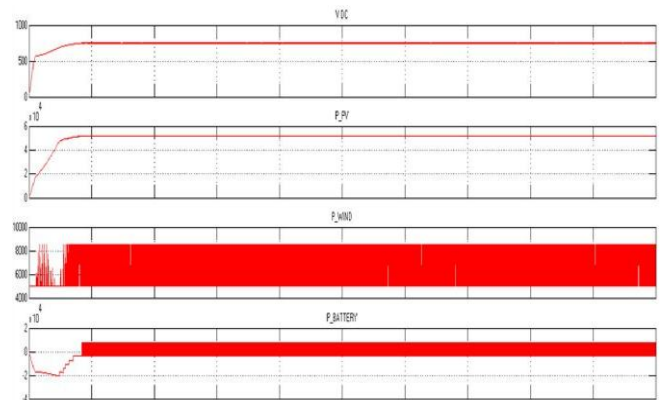

Fig.8 : Power at insolation 1000 w/m2, load : 40 KW

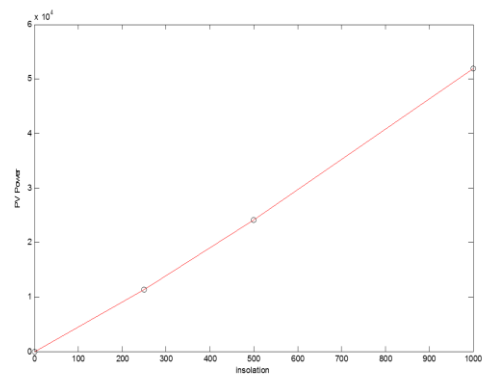

Fig.9 : PV power vs. insolation curve

| G | Load | PV | | |
|------|------|-------|-------|----------|
| W/m2 | KW | I (A) | V (V) | P (W) |
| 1000 | 30 | 69.17 | 761.6 | 5.27e+04 |
| 500 | 30 | 33.57 | 735.1 | 2.47e+04 |
| 250 | 30 | 15.97 | 715.2 | 1.14e+04 |
| 0 | 30 | 0 | 705.1 | 0 |

| | | | | |
|------|----|-------|-------|----------|
| 1000 | 40 | 69.17 | 750.1 | 5.19e+04 |
| 500 | 40 | 33.57 | 716.3 | 2.41e+04 |
| 250 | 40 | 15.97 | 705.1 | 1.13e+04 |
| 0 | 40 | 0 | 690.8 | 0 |

Table 1 : Result of PV System

| G | Load | Wind | | |
|------|------|-------|--------|---------|
| | | I (A) | V (V) | P (W) |
| 1000 | 30 | 8.58 | 615.96 | 5274.53 |
| 500 | 30 | 9.08 | 615.25 | 5584.14 |
| 250 | 30 | 7.13 | 614.79 | 4381.5 |
| 0 | 30 | 2.57 | 614.3 | 1580.19 |
| 1000 | 40 | 19.25 | 615.65 | 8500 |
| 500 | 40 | 10.17 | 614.8 | 6254.52 |
| 250 | 40 | 5.53 | 614.26 | 3398.46 |
| 0 | 40 | 0.56 | 613.65 | 343.37 |

Table 1 : Result of Wind System

| G | Load | Battery | |
|------|------|---------|-----------|
| | | I (A) | P (W) |
| 1000 | 30 | 10 | 7616 |
| 500 | 30 | -5 | -3676 |
| 250 | 30 | -15 | -1.07e+04 |
| 0 | 30 | -25 | -1.76e+04 |
| 1000 | 40 | 10 | 7501 |
| 500 | 40 | -15 | -1.07e+04 |
| 250 | 40 | -25 | -1.76e+04 |
| 0 | 40 | -25 | -1.72e+04 |

Table 1 : Result of Battery System

5. CONCLUSION

This dissertation is on modelling of a hybrid wind/PV alternative energy system. The main part of the dissertation focuses on the modelling of different energy systems.

A hybrid wind/PV system is proposed in this dissertation. Wind and PV are the primary power sources of the system, and the battery is used as a backup and long term storage unit.

Based on the dynamic component models, a simulation model for the proposed hybrid wind/PV energy system has been developed successfully using MATLAB/Simulink. The overall power management strategy for coordinating the power flows among the different energy sources is presented in the dissertation. Simulation studies have been

carried out to verify the system performance under different scenarios using practical load profile and real weather data. The results show that the overall power management strategy is effective and the power flows among the different energy sources and the load demand is balanced successfully.

6. APPENDICES

| | |
|------------------------------------|-----------|
| Nominal Mechanical o/p power (W) | 8.5e3 |
| Base Power of Electrical Gen.(VA) | 8.5e3/0.9 |
| Base Wind Speed (m/s) | 12 |
| Max. Power at Base Wind Speed (pu) | 0.8 |
| Base Rotational Speed (pu) | 1 |
| Pitch Angle Beta to Wind | 0 |
| Turbine Power Characteristic (deg) | |

Table 4 : Wind Energy Gen. System Parameters

ACKNOWLEDGEMENT

Author Vishal Prajapati wishes to thank the Department of Electrical Engineering, Tatva Institute of Technological Studies, Modasa for the working of Project under the guidance of Electrical faculty.

REFERENCES

- [1] M.MAHALAKSHMI, Dr.S.LATHA,"modeling, simulations and sizing of photovoltaic/wind/fuel cell hybrid generation system" International Journal of Engineering Science and Technology (IJEST), Vol. 4 No.05 May 2012.
- [2] M.M Hoque , I.K.A Bhuiyan , Rajib Ahmed, A.A .Farooque & S.K Aditya," Design, Analysis and Performance Study of a Hybrid PV Diesel - Wind System for a Village Gopal Nagar in Comilla", Global Journal of Science Frontier Research Physics and Space Sciences Volume 12 Issue 5 Version 1.0 year 2012.
- [3] Rosana Melendez1, Dr. Ali Zilouchian2 Dr. H. Abtahi3, Power Management System applied to Solar/Fuel Cell Hybrid Energy Systems, 8th Latin American and Caribbean Conference for Engineering and Technology, June 1-4, 2010.
- [4] Guiting Xue, Yan Zhang and Dakang Zhu, "Synthetically Control of a Hybrid PV/FC/SC Power System for Stand-Alone Applications" Research Journal of Applied Science, Engineering and Technology.
- [5] Esmaeil Alikhani, Mohammad Ahmadian, Ahmad Salemnia, Optimal Short-term Planning of a Stand-Alone Micro grid with Wind/PV/Fuel Cell/Diesel/Micro turbine, Canadian Journal on Electrical and Electronics Engineering Vol. 3, No. 3, March 2012.

[6] Caisheng Wang and M. Hashem Nehrir, "Power Management of a Stand-Alone Wind/Photovoltaic/Fuel Cell Energy System" IEEE TRANSACTIONS ON ENERGY CONVERSION, VOL. 23, NO. 3, SEPTEMBER 2008.

[7] M. Hashem Nehrir and Caisheng Wang "Modelling and Control Of Fuel Cells Distributed Generation Application". International Journal of Advanced Research in Electrical, Electronics and Instrumentation Engineering December 2013.

[8] T.U. Townsend, A Method for Estimating the Long-Term Performance of Direct-Coupled Photovoltaic Systems, MS thesis, University Of Wisconsin - Madison, 1989.

[9] Hohm, D. P. & M. E. Ropp "Comparative Study of Maximum Power Point Tracking Algorithms" Progress in Photovoltaic: Research and Applications November 2002, page 47-62.

[10] Dezso Sera, Tamas Kerekes, Remus Teodorescu and Frede Blaabjerg "Improved MPPT algorithms for rapidly changing environmental conditions".