

DESIGN AND FABRICATION OF SOLAR POWERED MULTIPURPOSE AGRICULTURAL MACHINE/VEHICLE/ROBOT

S. Ram kumar¹, K. Rajesh², V. Ranjith kumar³, M. Purosothaman⁴

Bachelor of Mechanical Engineering Student, Department of Mechanical Engineering , KANCHI PALLAVAN ENGINEERING COLLEGE Kanchipuram, Tamil Nadu, India

Abstract - Agriculture being one of the major occupation in India, Agriculture plays a vital role in the Indian economy. Indian agriculture has registered impressive growth over last few decades. It is very essential to discover and implement new idea in this field, though lot of work has been done in this area. It is unfortunate that, these ideas are not being implemented properly in actual field. This is due to high cost and is complicated for rural people. Multipurpose agriculture or farming machine is basic and major machine involved in agriculture for maximum yielding. The Conventional method of weeding, seed sowing and pesticide spraying is a laborious process and hence for that reason there is a scarcity of labours and basically, many farmers in India also use bullocks, horses and buffalo for farming operation. This will not satisfy need of energy requirement of the farming as compared to other countries in the world. This result in delayed agriculture crop production practices to overcome these difficulties, we are thinking that human and animal efforts can be replaced by some advance mechanism which will be suitable for small scale farmer from economical and effort point of view. So, we are developing this machine which will satisfy all this need and to solve labour problem. A solar powered multipurpose agricultural machine is designed for weeding, seed sowing and pesticide spraying purpose.

Key Words: Agricultural, solar, labour, bullocks, growth, farmer.

1. INTRODUCTION

Agriculture is the backbone of India. The history of Agriculture in India dates back to Indus Valley Civilization Era and even before that in some parts of Southern India. Today, India ranks second worldwide in farm output. The special vehicles plays a major role in various fields such as industrial, medical, military applications etc., The special vehicle field are gradually increasing its productivity in agriculture field. Some of the major problems in the Indian agricultural are rising of input costs, availability of skilled labour, lack of water resources and crop monitoring. To overcome these problems, the automation technologies were used in agriculture. The automation in the agriculture could help farmers to reduce their efforts. The vehicles are being developed for the processes for weeding, seed sowing, levelling and water spraying. All of these functions have not yet performed using a single vehicle. In this the robots are developed to concentrate in an efficient manner and also it is expected to perform the operations autonomously. The

proposed idea implements the vehicle to perform the functions such as ploughing, seed sowing, mud levelling and water spraying. These functions can be integrated into a single vehicle and then performed.

1.1 Objectives

- To reduce human effort in the agricultural field with the use of small machine.
- To perform all 4 operations at single time, hence increases production and saves time.
- To complete large amount of work in less time.
- The usage of solar can be utilized for Battery charging. As the Machine works in the field, the rays of the sun can be used for solar power generation

1.2 solar power

Every day, the sun radiates an enormous amount of energy called solar energy. It radiates more energy in one day than the world uses in one year. This energy comes from within the sun itself. Like most stars, the sun is a big gas ball made up mostly of hydrogen and helium gas. The sun makes energy in its inner core in a process called nuclear fusion. It takes the sun's energy just a little over eight minutes to travel the 93 million miles to Earth. Solar energy travels at the speed of light, or 186,000 miles per second, or 3.0×10^8 meters per second. Only a small part of the visible radiant energy (light) that the sun emits into space ever reaches the Earth, but that is more than enough to supply all our energy needs. Every hour enough solar energy reaches the Earth to supply our nation's energy needs for a year solar energy is considered a renewable energy source due to this fact. Today, people use solar energy to heat buildings and water and to generate electricity. Solar energy accounts for a very small percentage of U.S. energy less than one percent. Solar energy is mostly used by residences and to generate electricity.

2. LITERATURE REVIEW

2.1 Blackmore S. (2007)

A systems view of agricultural robotics

This research paper presents design and development of Agricultural robotics. In this they present objective of seed

planter machine design, factors affecting seed emergence, some mechanisms. The basic objective of sowing operation is to put the seed and fertilizer in rows at desired depth and seed to seed spacing, cover the seeds with soil and provide proper compaction over the seed. The recommended seed to seed spacing and depth of seed placement vary from crop to crop and for different agro-climate conditions to achieve optimum yields. From this we know that mechanical factors effects on seed germination like uniformity of depth of placement of seed, uniformity of distribution of seed along rows.

In this power transmission mechanism, seed meter mechanisms, weeder mechanism etc. The working as machine is pushed; power wheel is rotating which transmit power to weeder through chain and sprocket mechanism. Now cam is mounted on sprocket shaft which push weeder towards downward direction. Once weeder is penetrate in soil and during backward stroke flapper is opened so seed get separated from weeder and inserted in weed. From this we get idea that if we use the belt having small holes with defined thickness then it is beneficial for our project. As our multipurpose vehicle is only for using of chain drives is useful.

In this paper authors draws our attention towards the performance factor of a power tiller. Among those demand for light weight power tiller was sought out most. Fuel efficiency and field capacity such parameters are also discussed. We take those points in consideration while designing a sustainable multifunctional agricultural vehicle.

2.2 Srinivasan R.Zanwar, R.D.Kokate (June2012)

This research paper presents design modification in multipurpose sowing machine. In this they present that for sowing purpose we import the machinery which are bulk in size having more cost. To prevent this they design multipurpose sowing machine which consists of hopper, seed metering mechanism, ground wheel, power transmission system, seed distributor, and tiller. In this they design model on PRO-E software.

Actually the working is very simple as the tiller rotates it directly transmit motion into ground wheel which directly connected through main shaft. A main shaft has a disc with scoops inside the hopper. When the ground wheel rotates the main shaft also rotates with the help of power transmission system. The scoops collect the seed from hopper and leave it inside the seed distributor. The tiller is having very good contact with ground.

In this papers authors have used certain multipurpose machine with help of this paper we were able to derive our attention to broader way also how attachments can be used for making a model more useful in efficient and sustainable way.

3. METHODOLOGY

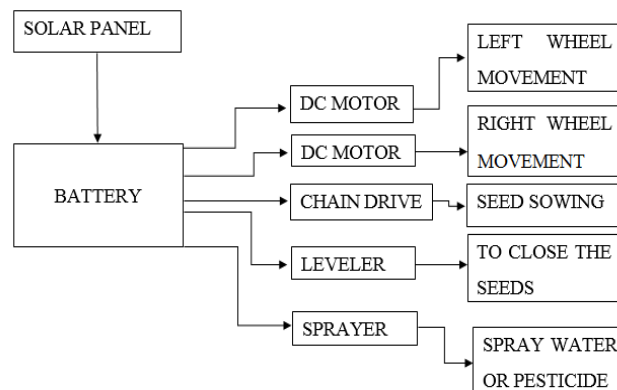

Block diagram

- The base frame is made for the 3 wheels connected and driven the rear wheel is dc motor.
- One end of the frame, cultivator is fitted which is also driven by dc motor and design is made to weed the soil.
- Hopper to store the seeds and the seeds flow through the funnel through the drilled hole on the shaft to the weed soil.
- On the end leveler is fitted to close the seeds to the soil, and water pump sprayer to spray the water.
- Solar panel is placed on top of the machine and is connected to the battery for charging the battery.
- Thus the max efficiency is utilized from the sun by the solar panel and to the battery
- The whole machine requires the 12v battery to operate the system
- Toggle switches are used to control the operation of the vehicle.

Table -1: Horizontal Distance between plants

s.no	Plants	Horizontal distance(ft)
1	Ground nut	1.25
2	Pearl millet	1.25
3	Sorghum	1.25
4	Sugar cane	1.25
5	Cotton	2 to 3
6	Soyabean	1.25
7	Corn	1.25

4. Working

The working of this solar powered multipurpose machine is based on the principles of motion transmission due to motor, chain and sprocket arrangement. The operator first stand behind the trolley. He will be handle and control the trolley forward by the uses of toggle switch. As trolley move forward, the wheel rotates in counter clockwise

direction. As sprocket is mounted on shaft of wheel, it also rotates in counter clockwise direction.

This motion is transferred to freewheel via transmission chain drive arrangement. The free wheel, thus, also starts rotating in counter clockwise direction. As freewheel and sprocket are mounted on same shaft, it also start rotating in anticlockwise direction. This will rotate sprocket in clockwise direction as it is externally meshed with it. Due to this, the disc start rotating which give motion to link as it is fixed on the disc.

The seed sowing arrangement is attached to disc via link. The seed sowing arrangement got motion due to this which stimulates seeds to come outside via vehicle movement. This continuously progress to sowing the seeds throughout from the hopper.

The weeder is to be placed the middle and bottom of the frame. This weeder is used to weed the farm land. This weeder is combined with the seed sowing arrangement. This arrangement can be used to sowing the seeds depends on the vehicle movement.

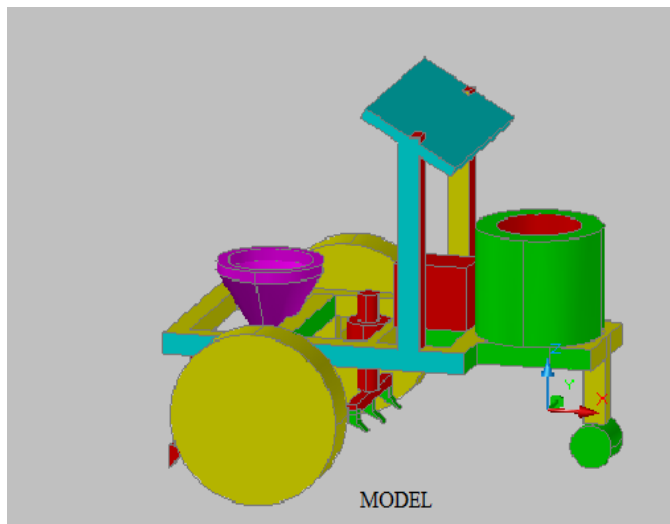

4.1 Advantages of Multipurpose machine

- Includes scientific forming techniques. Sequence spacing seed sowing machine has more advantages than regular seed sowing machine.
- Involves precision forming and fool proofing technology. By using this machine, a single seed can be placed in the desired spacing, so that the wastage of the seeds will be reduced. This will reduce the thinning operation during the germination time.
- Suitable for all types of seed to seed forming.
- Low cost, it's the lowest priced multipurpose agricultural equipment ever built.
- Reduces labours because of automation
- Reduces time consumptions, since it is a three row operated equipment.

- Machine can be used to operate small farming land.
- Eco friendly
- Fuel less process

5 Result and Discussion

5.1 Result

Practically our multipurpose agricultural equipment can be used for weeding, fertilizing, seed sowing, levelling and also used for weed removal purposes. All the parts are connected in such a way that in every stage of agriculture the equipment can be rearranged or easily assembled with fasteners to required length and specifications of field operation.

The working model of solar powered multipurpose machine successfully functioned and the machine can perform their operation such as weeding, seed sowing, and pesticide spraying and levelling the soil successfully.

Then the working model is performed well and proved their functions.

5.2 Future scope

By increasing the equipment strength and quality to its peak, we can have multipurpose agricultural equipment for life time usage. By providing hydraulics, gear arrangements and some minor adjustments the equipment can also be made as tractor powered equipment.

6 CONCLUSION

After the manufacturing and trail on the "Multipurpose Agricultural machine" conclusion made are as follows:

- Based on the overall performance of the machine we can definitely say that the project will satisfy the need of small scale farmer, because they are not able to purchase costly agricultural equipment.
- The machine required less man power and less time compared to traditional methods, so if we manufacture it on a large scale its cost gets significantly reduce and we hope this will satisfy the partial thrust of Indian agriculture.
- So in this way we can overcome the labour problem that is the need of today's farming in India

PHOTOCOPY



REFERENCES

- [1] Srinivasan R.Zanwar, R.D.Kokate (June2012), Advanced Agriculture System, International Journal of Robotics and Automation (IJRA) magazine.
- [2] R. Eaton, J. Katupitiya , S.D. Pathirana (2008), Autonomous Farming Modelling And Control Of Agricultural Machinery in a unified framework,15th international conference on mechatronics and machine vision in practice, New Zealand.
- [3] Blackmore S. (2007). A systems view of Agricultural Robotics. Precision Agriculture conference, Wagon Academic Publishers, Netherlands.
- [4] Simon Blackmore, Bill Stout, Maohua Wang, Boris Runov (2005), Robotic agriculture - The future of agriculture mechanism, Agro Technology, the royal veterinary and agriculture University.
- [5] Butler, S. (1887). Luck, or cunning, as the main means of Organic Modification? An attempt to throw additional light upon Darwin's theory of natural selection. (London: Trübner & Co.) Reprinted as vol 8 of The Shrewsbury Edition of the works of Samuel Butler (London: Jonathan Cape, 1924)
- [6] Leropoulos I, Greenman, J., and Melhuish, C. (2003). Imitating metabolism: Energy autonomy in biologically inspired robots. AISB '03 Second international symposium on imitation in animals and artefacts. Aberystwyth, Wales, pp.191-194.
- [7] Tillett, N.D., Hague, T. and Marchant, J.A. (1998) A robotic system for plant scale husbandry. Journal of Agricultural Engineering Research, 69, 169-178.