

Motion Detection Using PIR Sensor

Yogesh Pawar¹, Abhay Chopde², Mandar Nandre³

^{1,2,3} Department of Electronics Engineering, Vishwakarma Institute of Technology, Pune

Abstract—Pyroelectric Infrared Sensor(PIR) are the sensors which are most widely used for cheap surveillance. Due to their high ended sensitivity and area of detection PIR sensors are popular in security. PIR sensors are excellent in human and animal detection. They are mostly used in triggering an intruder alarm and activate household appliances upon the presence of a human. However, the output from the sensor is proportional to several temporal relationships between an object in the field of view of the sensor, the sensitivity of the sensor, PIR lens features, and the environmental heat conditions.

Index Terms— PIR sensor, Fresnel Lenses, Motion Sensor, IR Radiation

I. INTRODUCTION

All objects and living things emits infrared rays above absolute zero temperature. This infrared rays are not visible to human beings by naked eyes, but this radiation can be detected by electronic devices designed for such a purpose. PIR sensors are called passive devices as they do not emit any energy to detect the presence of objects.

They work entirely by detecting infrared radiation emitted by or reflected from objects. Due to their property of detecting infrared rays they are mostly used to detect motion of humans [1]. They are having small, inexpensive, low-power, easy to use properties also they don't wear out. For that reason, they have become more common in home appliances and gadgets used businesses [3]. They are also known by names like PIR, "Passive Infrared", "Pyroelectric", or "IR motion" sensors.



Figure 1: External overview

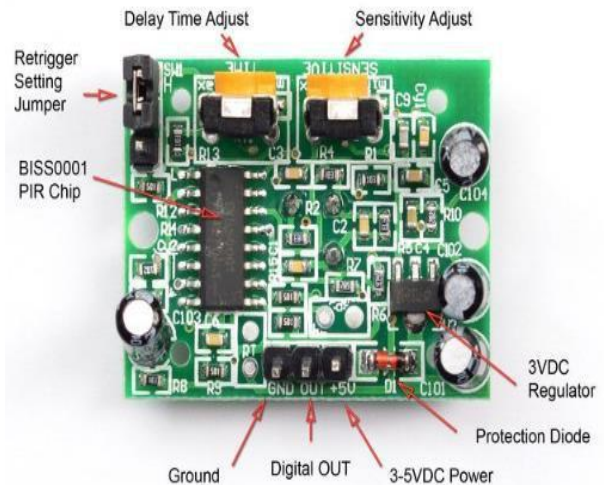

Figure 2: Internal components

All objects radiate energy as function of their temperature relative to absolute zero [2] which is in form of black body radiation rays. This black body radiation is detected by PIR sensors. The sensor responds to infrared radiation in the wavelength of 10µm (10 microns, or 10,000nm). This is the approximate body temperature of people and animals.

The word "passive" in the term "passive infrared" refers to principle nature of sensor. Proximity sensors must generate their own infrared radiation actively, which is interrupted or reflected by nearby objects whereas PIR doesn't need to generate or emit any type of radiation.

The PIR, or passive infrared, detectors are most commonly used in intruder alarm systems. A PIR is more likely to a remote thermal sensor [5]. These infrared sensors/detectors are the secret inside motion sensor security lights that illuminate driveways when someone approaches. Infrared is outside our eyes' light-detecting abilities.

II. TYPES OF MOTION SENSOR

The different motion sensor types include:

Passive infrared (PIR) — The most common motion sensor for residential properties, PIRs detect body heat, which alters infrared energy. When a sensor detects the slightest

change in temperature within its protective grid, it signals an alarm. In the past, PIRs could be tripped by incoming sunbeams, but this issue has been rectified in newer infrared sensors.

Micro Wave (MW) — Used primarily on commercial and industrial premises, MWs emit microwave pulses across spaces to detect movement. MWs cover longer ranges and wider areas than PIRs.

Dual technology sensors — For more advanced security systems, combination of PIR and MV is used. Therefore, one sensor is passive and the other is active. Each sensor works on different parts of the spectrum, and both sensors must be triggered for an alarm to activate.

Area-reflective sensors — These are incorporated into LEDs, from which infrareds are emitted to detect movement within the range of a lighted area.

Ultrasonic sensors — This sensor type is similar to the MV, only with ultrasonic waves, which detect movement across spaces.

Vibration sensors — One of the cheapest options, vibration sensors are switch-activated to send out vibrations that detect motion

III. WORKING

The operation of the PIR sensors are different and complex as compared to any other sensors. The complexity arises because there are multiple variables that affect the sensors input and output.

The PIR sensors detect changes in amount of infrared radiations incident on it. The IR radiations vary depending on the surface characteristics and the temperature of the object in front of the sensor. Whenever any object like human being passes in front of the PIR sensor, the temperature of the area will change from the room temperature to body temperature. The temperature will be back again when the object has moved ahead.

Amount radiated from the room or walls or outdoors. The first half of detecting area gets triggered when a warm body of human or animal passes by PIR sensor it causes a differential positive pulse as output. When the warm body leaves the sensing area, the reverse happens, whereby the sensor generates a negative differential change.

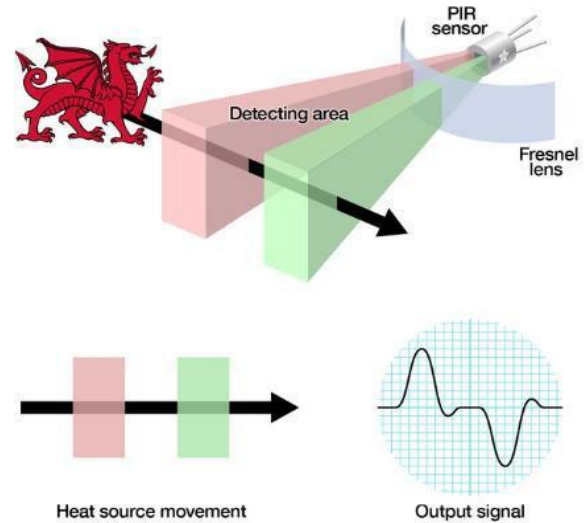

Figure 3: Output signal and heat source movements

The PIR sensor comprises of two slots. These slots are sensitive to IR radiations and are made of a special material. The lens shown above is used so that the sensor can see around some distance. The amount of IR detected by the two slots is same, which is radiated by the walls of house or any other walls. Whenever a body with some nonzero temperature like human body or animal passes in front of the PIR sensor it is first detected by the first half of the PIR sensor. This detection causes a positive differential change between the two halves of the sensor. When the warm body leaves the sensing area, the reverse process of the above take place.

The most common configurations have Fresnel lenses and an effective range of about 10 meters (30 feet) and field of view less than 180 degrees. Models which have field of view of about 360 degrees have been designed which are used to mount on a ceiling. Some PIR sensors can sense the change in IR radiations over thirty meters (one hundred feet) away from the sensor.

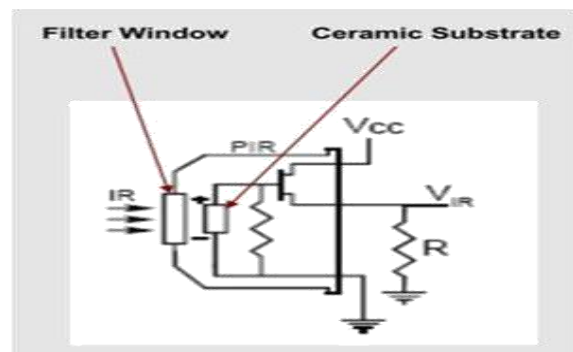

Figure 4: Internal circuit

LENS:

PIR sensors doesn't vary much from each other. only difference found in them is of prize and sensitivity. This variation is caused by optical parts [16]. The PIR sensors can be manufactured very cheaply. A lens cost few cents and vary length, breadth, range very easily.

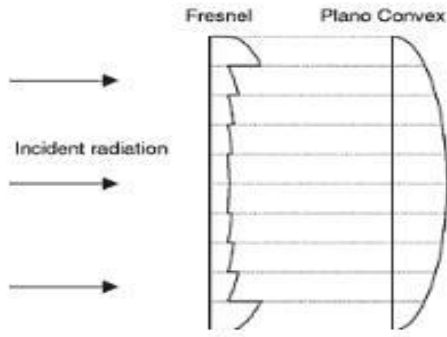

Figure 5: Fresnel Lens

In the diagrams shown above, the lenses are shown as plastic pieces. This means that the detection area will be around the two triangles. The sensor should have a larger detection area so that it can cover more area and tell us about motion

So, we can say that Fresnel lens is just a piece of plastic but without it PIR sensor's range is restricted for two rectangular part only. Hence Fresnel lens increases the area range and sensitivity.

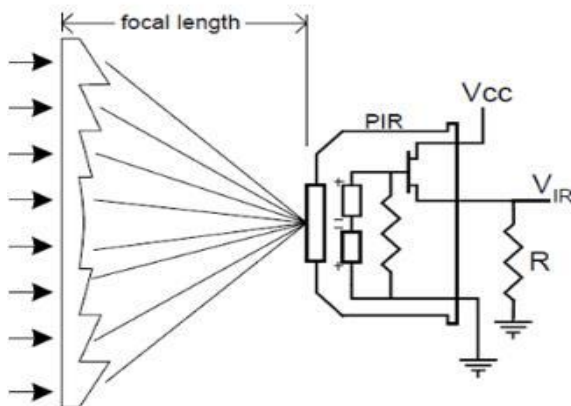

Figure 6: Fresnel lens locus on heat sensing element

IV. RESULT:

The PIR Sensor's range is affected by:

1. The setting of sensitivity jumper on sensor.

2. The thermal properties and size of nearby objects.
3. Environmental conditions like ambient temperature and light sources.

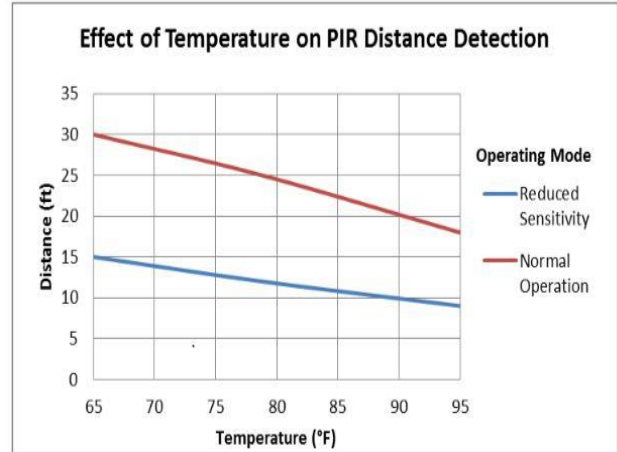

Figure 7: Effect of temperature over distance

The graph drawn above shows the approximate effects of increasing ambient temperatures on the PIR Sensor's detection range of an average adult.

CONCLUSION:

This paper proposed importance and application of PIR sensor. As surrounding temperature increases, sensitivity of passive infrared sensor decreases.

Sensitivity and resolution also decreases when distance between object and PIR sensor increases. PIR sensors are not only used in motion detection but also used in temperature sensing from remote places.

VI. APPLICATION:

PIR sensors are primarily used for detecting motion of the object, which is significantly spread over intruder alarms i.e. for security purposes, Automatic ticket gates, Entry way lighting, Security lighting, Automated sinks/toilet flusher, Hand dryers, Automatic doors [11].

Apart from motion detecting, PIR sensors are implemented in various devices which measures the temperature of a remote object.

In such a device, a non-differential PIR output is used. IR spectrum of a specific type of matter is observed and according to that calibration output signal is evaluated. Which gives us exact value of temperature from remote place.

PIR sensors are also used as heat Detectors. They are being used in many industrial safety applications as well as domestic security purposes [18].

Due to their low power and space consumption property PIR sensors are getting used in wide applications.



Figure 8: Basic Security system application of PIR where Bluetooth is sending data to mobile.

VII. REFERENCES:

- [1] Resident location-recognition algorithm using a Bayesian classifier in the PIR sensor-based indoor location-aware system HH Kim, KN Ha, S Lee, KC Lee - IEEE Transactions on ..., 2009 - ieeexplore.ieee.org
- [2] Development of PIR sensor based indoor location detection system for smart home KN Ha, KC Lee, S Lee - SICE-ICASE, 2006. International Joint ..., 2006 - ieeexplore.ieee.org
- [3] PIR-sensor-based lighting device with ultra-low standby power consumption CH Tsai, YW Bai, CA Chu, CY Chung... - IEEE Transactions on ..., 2011 - ieeexplore.ieee.org
- [4] Pyroelectric infrared sensor for intruder detection M Moghavvemi, LC Seng - TENCON 2004. 2004 IEEE Region ..., 2004 - ieeexplore.ieee.org
- [5] Surveillance tracking system using passive infrared motion sensors in wireless sensor network B Song, H Choi, HS Lee - Information Networking, 2008. ICOIN ..., 2008 - ieeexplore.ieee.org
- [6] A pyroelectric infrared sensor-based indoor location-aware system for the smart home S Lee, KN Ha, KC Lee - IEEE Transactions on Consumer ..., 2006 - ieeexplore.ieee.org
- [7] Smart homes for the elderly dementia sufferers: identification and prediction of abnormal behaviour A Lotfi, C Langensiepen, SM Mahmoud... - Journal of ambient ..., 2012 - Springer
- [8] Design and implementation of a distributed fall detection system based on wireless sensor networks X Luo, T Liu, J Liu, X Guo, G Wang - EURASIP Journal on Wireless ..., 2012 - Springer
- [9] A review of approaches to mobility telemonitoring of the elderly in their living environment CN Scanaill, S Carew, P Barralon, N Noury... - Annals of biomedical ..., 2006 - Springer
- [10] Extracting spatiotemporal human activity patterns in assisted living using a home sensor network D Lymberopoulos, A Bamis, A Savvides - Universal Access in the ..., 2011 - Springer
- [11] Analysis of target detection performance for wireless sensor networks Q Cao, T Yan, J Stankovic, T Abdelzaher - ... Computing in Sensor Systems, 2005 - Springer
- [12] An integrated pyroelectric infrared sensor with a PZT thin film CC Chang, CS Tang - Sensors and Actuators A: Physical, 1998 - Elsevier
- [13] Building occupancy detection through sensor belief networks RH Dodier, GP Henze, DK Tiller, X Guo - Energy and buildings, 2006 - Elsevier
- [14] Wireless sensor network deployment for integrating video-surveillance and data-monitoring in precision agriculture over distributed crops AJ Garcia-Sanchez, F Garcia-Sanchez... - ... and Electronics in ..., 2011 - Elsevier
- [15] Wavelet based flickering flame detector using differential PIR sensors F Erden, BU Toreyin, EB Soyer, I Inac, O Gunay... - Fire Safety Journal, 2012 - Elsevier
- [16] Test bed for measurement of angular parameters of passive infrared sensors M Kastek, H Madura, M Morawski, T Piatkowski... - Infrared physics & ..., 2007 - Elsevier
- [17] Infrared motion sensing system for human-following robots G Feng, X Guo, G Wang - Sensors and Actuators A: Physical, 2012 - Elsevier
- [18] Measuring and monitoring occupancy with an RFID based system for demand-driven HVAC operations N Li, G Calis, B Becerik-Gerber - Automation in construction Elsevie.