

ELECTROCARDIOGRAPH ANALYSER USING ANDROID

Indhu K R¹, Jefna James², Sravya T S³

^{1,2,3} Student, Dept. of Electrical and Electronics Engineering, Mar Athanasius college of Engineering, Kothamangalam, Kerala, India

Abstract – Cardiovascular diseases, which include diseases of the heart, are the leading cause of death worldwide. The majority of cardiovascular disease is non communicable and related to lifestyle and other factors, becoming more prevalent with ageing. ECG monitoring in daily life is a necessary way for curing heart disease, and it is also a hot issue in medical and engineering fields. Widespread use of ECG monitoring is a pretty distant goal for developing world and poor nations, due to the high cost of ECG machines, bulky ECG equipment, the need for a specialist to operate the ECG device. With the rapid development of mobile internet and integrated circuit technology, it is possible to build a ECG monitoring system by using of smartphones equipped with a Bluetooth. Besides lowering ECG monitoring cost, patients may have their ECG recorded at home. To make it easier for the medical to monitor the ECG of their patients outside the hospital with a minimum cost, we designed and developed an ECG monitoring system based on Android smart phone. Furthermore, the detailed investigations using MATLAB/SIMULINK is explored in this paper.

Key Words: Cardiovascular disease, Android, Arduino, Electrocardiography, Bluetooth

1. INTRODUCTION

Cardiovascular diseases are the leading cause of death globally. Together they resulted in 17.9 million deaths (32.1%) in 2015, up from 12.3 million (25.8%) in 1990. Deaths, at a given age, from CVD are more common and have been increasing in much of the developing world, while rates have declined in most of the developed world since the 1970s. Coronary artery disease and stroke account for 80% of CVD deaths in males and 75% of CVD deaths in females. Most cardiovascular disease affects older adults. In the United States 11% of people between 20 and 40 have CVD, while 37% between 40 and 60, 71% of people between 60 and 80, and 85% of people over 80 have CVD. The average age of death from coronary artery disease in the developed world is around 80 while it is around 68 in the developing world. Disease onset is typically seven to ten years earlier in men as compared to women.

1.1 Electrocardiography

Electrocardiography (ECG) is the process of recording the electrical activity of the heart over a period of time using electrodes placed on the skin. These electrodes detect the tiny electrical changes on the skin that arise from the heart muscle's electro physiologic pattern of depolarizing and repolarizing during each heartbeat. It is a very commonly

performed cardiology test. During each heartbeat, a healthy heart has an orderly progression of depolarization that starts with pacemaker cells in the sinoatrial node, spreads out through the atrium, passes through the atrioventricular node down into the bundle of His and into the Purkinje fibers, spreading down and to the left throughout the ventricles. This orderly pattern of depolarization gives rise to the characteristic ECG tracing. To the trained clinician, an ECG conveys a large amount of information about the structure of the heart and the function of its electrical conduction system. Among other things, an ECG can be used to measure the rate and rhythm of heartbeats, the size and position of the heart chambers, the presence of any damage to the heart's muscle cells or conduction system, the effects of cardiac drugs, and the function of implanted pacemakers. Medical uses for this information are varied and generally relate to having a need for knowledge of the structure and/or function.

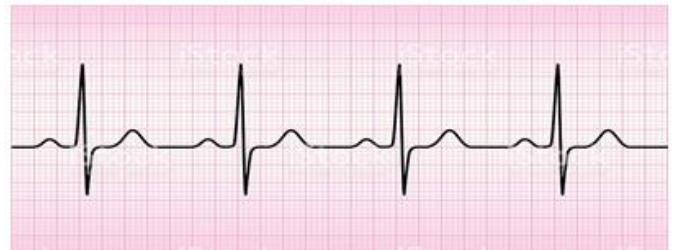

FIG-1 ECG Signal

1.2 ECG monitoring system using Android

ECG monitoring is the effective way in both forecasting heart disease and keeping cardiac patients under tight surveillance of their heart conditions. Widespread use of ECG monitoring is a pretty distant goal for poor nations or people. The main reasons for that are the high cost of ECG machines, bulky ECG equipment, the need for a specialist to operate the ECG device. One way to cut down cost of ECG monitoring devices is to implement a ECG monitoring system using android mobile phone equipped with wireless Bluetooth technology. Besides lowering ECG monitoring cost. Patients may have their ECG recorded at home, avoiding transporting to distant hospitals. This might be quite convenient for elderly patients, and patients living in the countryside where doctors are not available..With the rapid development of mobile Internet and integrated circuit technology, it is possible to complete the human health detection by using of smart phones. Compared with the traditional heart rate meter, this method is more flexible. In addition to replacing expensive and bulky traditional ECG

machines, mobile phone-based ECG monitoring devices offer the instant warning about the heart condition of the patient. So, life threatening arrhythmias and ECG alterations appear before a sudden heart attack occurs and the chance to survive such an event is become higher.

2. BLOCK DIAGRAM

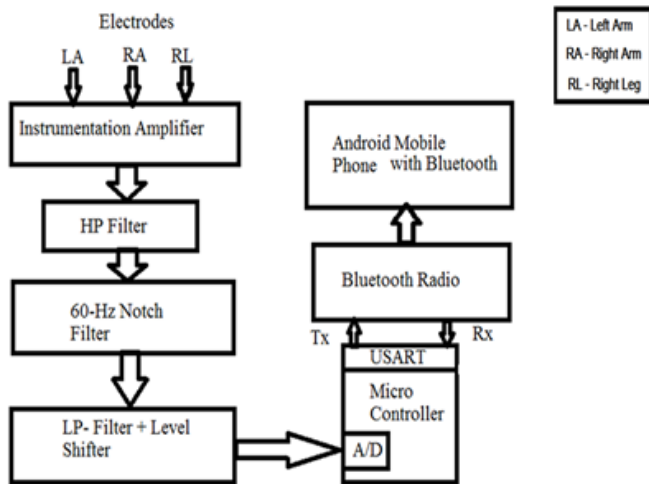

Fig-2 Block diagram for ECG Monitoring

ECG monitoring system comprises three distinct subsystems.

- To process the analog ECG signal.
- Micro-controller and Blue-tooth Module.
- Android Mobile phone.

Subsystem 1 :

Processing Signal :This subsystem is to process the analog ECG signal obtained from the human body and convert it to digital world.

This subsystem comprises of:

- Instrumentation Amplifier: An instrumentation amplifier is a type of differential amplifier that has been outfitted with input buffer amplifiers, which eliminate the need for input impedance matching and thus make the amplifier particularly suitable for use in measurement and test equipment. It will amplify the ECG signal to a particular level.
- HP-Filter: It will block the unwanted high amplitude DC component of the amplified signal.
- 60Hz- Notch Filter: the function is to filter out the main 60Hz interference noise on the ECG signal. It also helps to buffer and process the signal.
- LP-Filter and Level Shifter: Function is to limit the signals Bandwidth and avoid errors due to aliasing during the sampling process.

Subsystem 2 : Micro-controller and Bluetooth Module: This unit samples the ECG serializes and transmits them via the Bluetooth module to the Android cell phone.

Subsystem 3 : Android Mobile :An application program written to the cell phone receives the ECG samples and plots the ECG signal on the mobile screen.

3. CIRCUIT AND SIMULATION

The signal conditioning circuit is simulated using MATLAB version 2015A. This simulation output is obtained by giving some sample ECG values as input to the MATLAB and these values are processed using Simulink PS Converter. These sample values then goes through different stages accompanying Instrumentation Amplifier, HPF Analog Buffer, Notch Filter, Active Low Pass Filter and Level Shifter.

An instrumentation amplifier receives the ECG detected by surface electrodes located on the patient's body and uses a resistor to set its gain to an appropriate value.

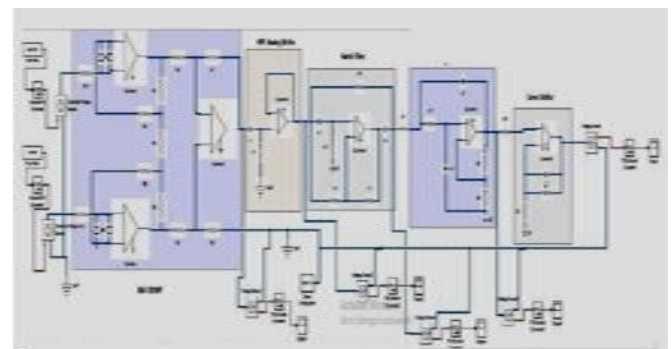

Fig-3 Simulation Circuit

The amplified ECG signal that appears at the output of the Instrumentation amplifier first goes through a RC high-pass filter (HPF). Its role is to block the unwanted high-amplitude dc component of the signal. The unwanted DC components will get eliminated at this stage while the other parameters of the ECG signal remained unchanged. The notch filter will get buffered and filter out the mains 60-Hz interference noise on the ECG signal. To limit the signals bandwidth avoid errors during the sampling process, signal is processed by active low-passfilter. The final analog signal processing task consisting in shifting the signal so that it fits suitably to the ADC's input voltage range. This is carried out by a level shifter.

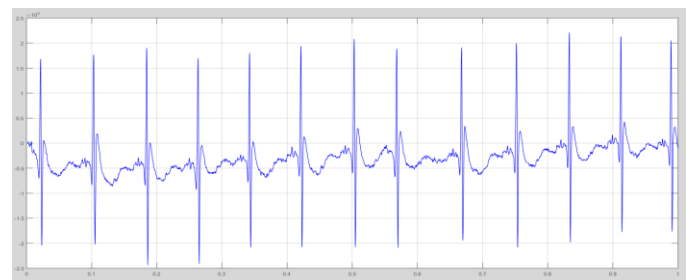

Fig-3.1 Simulation Result

4. HARDWARE IMPLEMENTATIONS

The hardware section of the proposed system is shown in the below figure. The system consist of AD8232 sensor module, AG-AGCl probes, Arduino nano microcontroller, organic LED display, Bluetooth module HC05, android mobile phone.

An AD8232 sensor module conditioned the ECG signal received via Ag-AgCl surface electrodes located on the patient's right arm (RA), left arm (LA) and right leg (RL) . The signal is given to the microcontroller and it samples the ECG and transmits serially to the Android cell phone via the Bluetooth module. An application program written to the cell phone receives the ECG samples and displayed on the screen as well as the OLED display

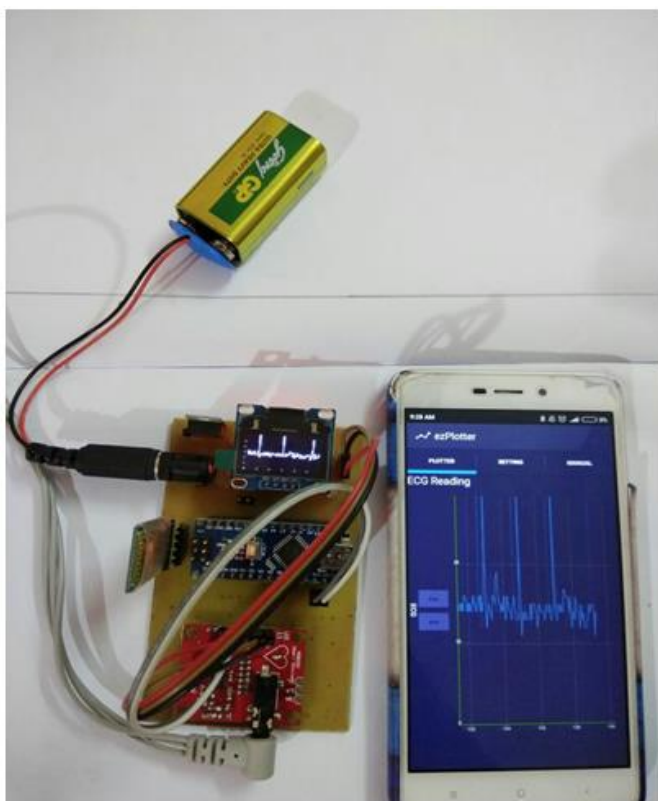

Fig-3.2 Hardware Setup

5.CONCLUSIONS

Android phone based health monitoring system has been presented in this paper. The proposed system mainly consist of an Android application, Arduino Uno microcontroller as well as heartbeat sensor. A link is established between the patient's Bluetooth enabled Mobile device and sensors via a Bluetooth module. Thus data from hardware is transmitted wirelessly to the mobile using Bluetooth . By using this system, the doctors can monitor, diagnose, and suggest medication to their patients.

ACKNOWLEDGEMENT

It is a great pleasure to acknowledge all those who have assisted and supported us for successfully completing our project. First of all, we thank God Almighty for his blessings as it is only through his grace that we were able to complete our project successfully. We take this opportunity to extend our sincere thanks to my project guide Prof. Geethu James, and all the members of the Department of Electrical & Electronics Engineering for sharing their valuable comments during the preparation of the project. We also extend our deep sense of gratitude to our Faculty Advisor Prof. Neena Mani, Electrical & Electronics Engineering Department for her creative suggestions during the preparation of the project. we express our deep sense of gratitude to Prof. Acy M Kottalil, Head of Electrical & Electronics Engineering Department. We are deeply indebted to Dr. Solly George, Principal, Mar Athanasius College of Engineering for her encouragement and support.

We whole - heartedly thank all my classmates, for their valuable suggestions and for the spirit of healthy competition that existed between us.

REFERENCES

- [1] G. Lanza, "The electrocardiogram as a prognostic tool for predicting major cardiac events," *Progress in Cardiovascular Diseases*, v. 50, n. 2, 2007, pp. 87-111.
- [2] N. Belgacem and F. Bereksi-Reguig, "Bluetooth portable device for ECG and patient motion monitoring," *Nature & Technology Review*, n. 4, 2011, pp. 19-23.
- [3] K. Liang, X. Zhang, Y. Wang, S. Huang, N. Guan, W. Pang, B. Li, and H. Chen, "A system of portable ECG monitoring based on Bluetooth mobile phone," *International Symposium on IT in Medicine and Education (ITME)*, v. 2, 2011, pp. 309-312.
- [4] Z. Yongning and Z. Guo, "A palm pilot based pocket ECG recorder," *IEEE EMBS International Conference on Information Technology Applications in Biomedicine*, 2000, pp. 110-112.
- [5] M. Engin, Y. Yamaner, and Z. Engin, "A biotelemetric system for human ECG measurements," *Measurement*, v. 38, 2005, pp. 148-153.