

# AUTOMATIC INSPECTION TROLLEY FOR RAILWAY TRACK CRACK DETECTION WITH TRACK CLEANING

RENUPRIYA.G<sup>1</sup>, HARIHARAN.G, DEEPADHARSHINI.D<sup>3</sup>, SURESH.K<sup>4</sup>, K.RAJA<sup>5</sup>

<sup>1, 2, 3, 4</sup> Final Year Students, Department of Electrical And Electronics Engineering, Knowledge Institute Of Technology

<sup>5</sup> Assistant Professor, Department of Electrical And Electronics Engineering, Knowledge Institute Of Technology

\*\*\*

**Abstract** - In railway system, railway track security is a prime concern. Some approaches have been implemented concerning the track breakage detection. From the starting of railway transportation to this date, scavenging rail tracks has been a puzzling social issue. In this, humans have to clean human waste and other garbage thrown on rail tracks is a situation that needs immediate remedy. This manual scavenging is leads to health problems. In this paper we are proposing an idea to solve both the problems. For this an inspection trolley is used for detecting the railway track crack and cleaning the track path automatically in synchronize with the database of the train details. This system comprises of microcontroller, GSM modem, GPS module, Ultrasonic sensor, IR sensor to bring into operation the crack detection, and Vacuum cleaner to clean the track path.

**Key Words:** Track crack, cleaning, controller, Ultrasonic sensor, Vacuum cleaner.

## 1. INTRODUCTION

In India, Railways is the most widely used transport system. In 1950 Government of India had taken over the entire railway system in the country. A single transport network connects far flung areas of the country. It is one of the largest transportation and logistics network of the world which runs 19,000 trains. It runs 12,000 trains to carry over 23 million passengers per day connecting about 8,000 stations spread across the sub-continent. By connecting various areas of the country railways have made internal trade convenient. Railways have increased the size of markets. The technology used in railways is quite out-dated. It needs to be modernised. So the incidence of railway accidents in our country is greater as compared to other countries. According to the Railways, out of 100 accidents, at least seven takes place due to fractured tracks. For example on March 30,2017 Crack in tracks apparently led to derailment. A crack in the tracks prima facie caused the derailment of eight coaches of Mahakaushal Express near Mahoba station in Uttar Pradesh. Eight bogies of the Jabalpur-NizamuddinMahakaushal Express had derailed 52 passengers were injured in the mishap, 21 were injured, The mishap left 400 metres of track damaged and disrupted rail traffic on the route with services of 14 trains disrupted. And cleanliness has become priority issue in Indian Railways. One of the biggest worries is the amount of solid waste (mainly paper and plastic) generated each day by train

passengers across the country. Solid waste generated in trains can be categorised as biodegradable, slowly degradable and non-biodegradable. The biodegradable waste component consists of food wastes. The slowly degradable waste component includes paper waste (like newspapers, disposable cups, food containers and lids); and the non-biodegradable waste component comprises plastic waste (like carry bags, bottles, cups and lids). A random survey says that each train generates 1,100 paper plates and containers, 1,750 paper cups and 800 plastic items (pouches and bottles) per day. Discharge of human waste from trains is also a cause for concern. All this waste is spread across the length and breadth of the country, contaminating land and soil, and polluting waterbodies. To clean these wastes huge money and man power are needed. Now considering both the problems we are proposing our idea to minimize accidents due to cracks in railway tracks and to automatically clean the wastes in the tracks.

## 2. LITERATURE SURVEY

Evolution of Railway Track Crack Detection System. In this paper, the presented system helps to detect the flaws in the rail track using ultrasound testing method. When the crack is detected, respective coordinates are sent to the nearest station. This recording and sending of coordinates are done by GPS and GSM module. Ultrasonic technique is the most effective method which detects minor cracks and also calculates the growth rate of the crack. When ultrasound wave signal propagates from one medium to another distinct medium, a certain proportion of the signal energy propagates over to the other medium, at the same time the remaining energy gets reflected back. After getting the reflected signals they measure the properties such as time difference of arrival (TDOA). By using this time delay they calculate the thickness and the flaws in the material.

Railway Track Breakage Detection Method using Vibration Estimating Sensor Network. In this paper, different kinds of rail defects inspection and maintenance methods are described and an algorithm is proposed that makes use of sensors for detecting cracks and breakages in the railway tracks. An algorithm for deployment of vibration sensors on the track and simulating communication among the sensors in real time. And also suggest a method to regularly update train engine about the track's status and exact location of the track breakage. Communication takes place on a full duplex

channel from sensors to sink and from sink to train. Aggregation in the proposed method is deterministic which gives exact location of crack whereas in complex fuzzy based approaches approximate location is identified so there is no guarantee for real time success.

Intelligent Track Cleaning Robot. It is to develop an efficient and economic device for cleaning the vast Indian railway network tracks. The proposed idea of automatic railway track cleaning system comprises an automatic vehicle that goes on land and track. It consists of a four-wheel running robot with a suction unit, cleaning unit, automatic displacement unit, an intelligent control system, an intelligent train sensing unit, and power unit. The entire machine is controlled by an onboard PIC microcontroller and the sensor networks on railway track.

### 3. PROPOSED SYSTEM

In this paper we are designing an inspection trolley to detect the crack in the railway track and simultaneously clean the track path only within the station limit. An inspection trolley is a mechanical arrangement that runs on the track. The supply of 5V DC is given to the microcontroller from battery source through the converter. The trolley incorporates controller, ultrasonic sensor, IR sensor, vacuum cleaner, disinfectant sprayer, GSM Modem and driver circuits. The controller is synchronized with the train database of the station that will provide the information about train arrival and departure. By using this information the trolley get started when the track is free and also crack checking unit, cleaning unit are powered. In the crack checking unit the ultrasonic sensor is checking the track continuously. When the crack is detected by the ultrasonic sensor, the trolley gets stopped and the alert message will send to the corresponding nearby station. The message contains the information about the breakage in the track and the exact location is identified by the GPS and the message will send through GSM. In cleaning unit, the vacuum cleaner cleans the track continuously. The wastes are disposed at the regular intervals. The cleaning process is continued within the station limit.

This is the block diagram of our proposed system. The block diagram contains battery, DC motor, converter, controller, IR sensor, ultrasonic sensor, disinfectant sprayer, GSM, vacuum cleaner. The details of each and every components of the block diagram are given below.

**BLOCK DIAGRAM**

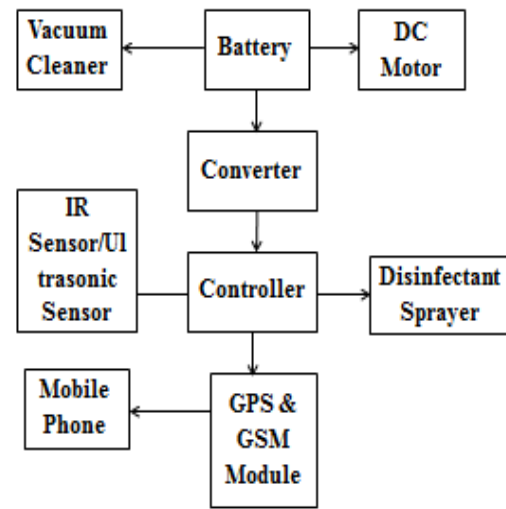

**Fig -1: Block Diagram**

#### BATTERY

An electric battery is a device consisting of one or more electrochemical cells with external connections provided to power electrical devices. In this we are using 12V DC batteries to power the controller through converter, drive circuit for running the DC motors and to vacuum cleaner.

#### DC MOTOR

A DC motor is rotary electrical machine that converts direct current electrical energy into mechanical energy. In our proposed system, four 12V DC batteries are used to run the inspection trolley. This motor is energized by battery source.

#### CONVERTER

Converter is used to convert constant DC voltage into required range of DC voltage. From the battery, the converter converts 12V into 5V DC required by the controller.

#### CONTROLLER

In this system, PIC microcontroller is used. This PIC microcontroller is energized by the battery through the converter. Because the controller required only 5V but the battery provides 12V so the converter is used. This controller is playing a major role in this project, it control and coordinates all the operation of the inspection trolley.

#### IR SENSOR

An infrared sensor is an electronic instrument which is used to sense certain characteristics of its surroundings by either emitting and/or detecting infrared radiation. In this IR sensor

is used to detect the object in the track. The object may be animal, human beings etc.

### ULTRASONIC SENSOR

An Ultrasonic sensor is a device that can measure the distance to an object by using sound waves. It measures distance by sending out a sound wave at a specific frequency and listening for that sound wave to bounce back. The ultrasonic sensor is used to detect the crack. When the crack is detected, the trolley gets stopped by the controller.

### DISINFECTANT SPRAYER

It is purely for hygiene purpose. This sprayer is connected at the back side of the inspection trolley. It sprays the disinfectant liquid like Dettol. It is for healthy and fragrance purpose. Disinfectant Sprays kill 99.9% of the viruses and bacteria it can be used to eliminate germs on commonly touched hard and soft surfaces.

### GSM MODEM AND GPS SYSTEM

GSM is a mobile communication modem; it stands for global system for mobile communication (GSM). GSM is an open and digital cellular technology used for transmitting mobile voice and data services. The Global Positioning System (GPS) is a satellite-based navigation system made up of at least 24 satellites. GPS works in any weather conditions, anywhere in the world, 24 hours a day. When the breakage is detected the alert message will send to the nearby station through GSM with the help of GPS.

### VACUUM CLEANER

It is an electrical apparatus that by means of suction collects dust and small particles from floors and other surfaces. In our system, the vacuum cleaner is main part of the cleaning unit. It collects dust and wastes from the track.

## 4. FUTURE SCOPE

In our present idea is to detect the crack and clean the wastes of the track automatically. Now we are checking the single track at a time but in future a single trolley can inspect the multiple tracks at a time. In future this system can be implemented by IoT for better performance. And also the trolley can be powered by solar. This is also increase the efficiency of the system.

## 5. CONCLUSIONS

This method is very simple and easy to detect the breakage in the railway tracks and to clean the track path simultaneously. So the accidents are avoided by the prior intimation to the corresponding stations. Nowadays they are inspecting the track manually it takes more time to inspect a single track and accuracy is also less. But our system takes less time to

inspect and accuracy is high. It also cleans the track automatically so it reduces the manpower required to clean the wastes. Hygiene is maintained for passenger's health purpose.

## REFERENCES

- [1] Dr. Manoj Hedao, Dr.SuchitaHirde ,Ms.Arshi Khan ,“Sanitationin indian railway premises: a great cause of concern” , International Journalof Advanced Engineering Technology, 2015
- [2] Mr. Rajesh Pant, Mr.MayankUniyal, Mr.PrashantRatodi “ManualScavenging and Technological Solution to Eradicate It. (Turning Scavengersto Engineers)”, IOSR Journal of Mechanical and Civil.
- [3] E. Prassler, E. Stroulia, M “Office Waste Cleanup: An Application ForService Robots” Strobe1Research Institute for Applied KnowledgeProcessingP.O. Box 2060,D 89010Ulm,Germany{prassler,skoulia,mstrobe1}@faw.uni-ulm.de
- [4] Harbhajan .S. Hayre, "Automatic Railroad Track Inspection" IEEE Transactions on Industry Applications, Vol. , No. 3, May/June1974.
- [5] Zeinab Sam Daliril, ShahaboddinShamshirband, Mohsen AmiriBesheli "Railway Security Through The Use of Wireless SensorNetworks Based on Fuzzy Logic" International Journal of the PhysicalSciences Vol. 6(3), pp. 448-458, 4 February, 2011
- [6] Prof. P.Navaraja, “Crack detection system forrailway track by using ultrasonic and pir sensor”, in “International journal ofadvanced information and communicationtechnology”, Volume -1, Issue-1, May 2014
- [7] Sireesha R, Ajay Kumar B, Mallikarjunaiah G and BharathKumar B, “Broken Rail Detection System using RFTechnology”, in “SSRG International Journal of Electronicsand Communication Engineering”, volume 2 issue 4- April2015