

Object Detection Based Garbage Collection Robot (E-Swachh)

Shobhit Khandare¹, Sunil Badak², Yugandhara Sawant², Sadiya Solkar²

¹Professor, Department of Electronics and Telecommunication, Vivekanand Education Society of Institute Technology, Mumbai, Maharashtra, India.

²Student, Department of Electronics and Telecommunication, Vivekanand Education Society of Institute Technology, Mumbai, Maharashtra, India.

Abstract - People are busy in their professional life and they forget to pay attention to their surrounding problems, which can lead to many hazards. One of the main problem is Garbage collection. Many times, it has been observed that the garbage which should be inside the dustbin is actually lying outside the dustbin and causing the pollution of the surrounding environment, which further leads to numerous diseases. To solve this problem a human intervention is required which sometimes may lead to hazardous health problems. This paper proposes the method where a robot can be used to clean the polluted areas such as garbage around the dustbin. A Robot is powered by Solar Panel, which again saves the electric power. Robot has the advantages of the powerful image processing and ultrasonic sensor to sense the surrounding area and accordingly action can be taken. An image processing has been used here to avoid interaction with the wild life. An Ultrasonic sensor is used to detect the object and the distance between the object and Robot. The Ultrasonic sensor is also used to employ a movement algorithm for the movement of the robot.

Key Words: Swachh Bharat Abhiyan, Arm, Image Processing, Distance measurement .

1. INTRODUCTION:

Garbage is the major problem not only in cities but also in rural areas of India. It is a major source of pollution. Indian cities alone generate more than 100 million tons of solid waste a year. In 2000, India's Supreme Court directed all Indian cities to implement a comprehensive waste-management programme that would include household collection of segregated waste, recycling and composting. These directions have simply been ignored. No major city runs a comprehensive programme of the kind envisioned by the Supreme Court. It is not wrong to say that India is on verge of garbage crisis even though 9000 crore rupees are allotted for the Swachh Bharat Abhiyan.

Also, Municipal solid waste workers (MSWWs) or refuse collectors, universally expose too many work related health hazards and safety risks, notably allergic and other diseases of the respiratory system. Health impacts could also entail musculoskeletal, gastro intestinal and infectious diseases as well as injuries caused by work-

related accidents. These problems come along by developing activities such as construction of houses, offices, and other business areas. The Environment problems occur due to several reasons; they are the low budget allocation on environment management and public awareness in protecting the environment. The Environment issue which comes up from year to year and still cannot be solved is about garbage and waste.

2. METHODOLOGY:

2.1. Motion of Robot :

The robot can travel in the predetermined path by using a combination of motors, drivers, and sensors connected to the Raspberry Pi-3B. This system consists of four geared motors of 10rpm each, motor drivers and ultrasonic sensor.

The ultrasonic sensors act as input to the Raspberry Pi-3B. The motors are connected to the output of the Raspberry Pi-3B through the drivers. The ultrasonic sensors detect the obstacles and the motors are made to rotate based on the pre-programmed instructions in Raspberry Pi-3B.

2.2. Garbage Collection:

The robot Garbage collection system consists of a set of an ARM connected to the motors. The mechanism will not operate for entirety of the vehicle operation and will rotate only for predetermined set of conditions. The main aim of the mechanism is to collect garbage which is of similar dimensions to that of juice cartons, crushed papers, and all light items whose height is between 5 to 10 cms. Mechanism is mounted on the front side of the base with an appropriate ground clearance. When the sensor detects an obstacle, the image processing is used to categorize the object as garbage or any living organism. The object detection is specifically used for safety of animals, so that they don't get harm. The garbage is picked and dropped into a bin which is placed right behind the mechanism. The robot keeps collecting the garbage until it reaches certain height in the bin. Once the bin is filled the collected garbage is disposed to a selected place.

3. SYSTEM OVERVIEW:

3.1. Block Diagram-

Overall block diagram of our model is shown in

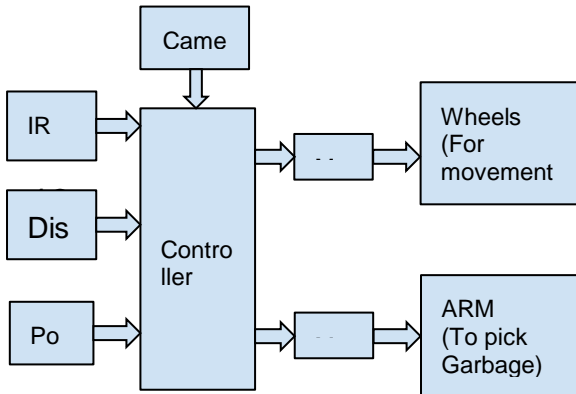

Figure -1 : BLOCK DIAGRAM

Ultrasonic sensors and IR sensors are used to avoid obstacle in robot's moving path. Waste collection is done by ARM with pick and drop movement. Raspberry pi is used as controller to control all movements of robot.

4. DESCRIPTION:

1. Controller (Raspberry Pi-3B):

Raspberry Pi 3B is the controller we are using. The Raspberry Pi 3 Model B is the third generation Raspberry Pi. This powerful credit-card sized single board computer can be used for many applications and supersedes the original Raspberry Pi Model B+ and Raspberry Pi 2 Model B. Whilst maintaining the popular board format the Raspberry Pi 3 Model B brings you a more powerful processor, 10x faster than the first generation Raspberry Pi. Additionally it adds wireless LAN & Bluetooth connectivity making it the ideal solution for powerful connected designs.

2. Ultrasonic Sensor

Ultrasonic sensor is a device used to measure the distance of an object by using sound waves. It can measure the distance by sending the sound waves at a specific frequency and listen the sound waves to bounce back. By using the elapsed time between the sound wave generated and sound wave bounce back, the sensor can be able to calculate the distance between the sensor and the object. The sound waves can be able to travel 2 times the distance to the object before it was detected by the sensor.

To find the distance to the object, the below given formula can be used,

$$\text{Distance} = (\text{speed of sound} * \text{time taken}) / 2$$

3. Camera:

The Raspberry Pi Camera Board plugs directly into the CSI connector on the Raspberry Pi. It's able to deliver a crystal clear 5MP resolution image, or 1080p HD video recording at 30fps. The sensor itself has a native resolution of 5 megapixel, and has a fixed focus lens onboard. In terms of still images, the camera is capable of 2592 x 1944 pixel static images, and also supports 1080p at 30fps, 720p at 60fps and 640x480p 60/90 video recording.

4. IR Sensor:

An infrared sensor emits and/or detects infrared radiation to sense its surroundings. The basic concept of an Infrared Sensor is used as Obstacle detector is to transmit an infrared signal, this infrared signal bounces from the surface of an object and the signal is received at the infrared receiver. There are five basic elements used in a typical infrared detection system: an infrared source, a transmission medium, optical component, infrared detectors or receivers and signal processing.

5. Driver(L293D):

L293D is a typical Motor driver or Motor Driver IC which allows DC motor to drive on either direction. L293D is a 16-pin IC which can control a set of two DC motors simultaneously in any direction. It works on the concept of H-bridge. H-bridge is a circuit which allows the voltage to be flown in either direction. Voltage need to change its direction for being able to rotate the motor in clockwise or anticlockwise direction. In a single L293D chip there are two h-Bridge circuit inside the IC which can rotate two dc motor independently. VCC is the voltage that it needs for its own internal operation 5v; L293D will not use this voltage for driving the motor. For driving the motors it has a separate provision to provide motor supply VSS. Max VSS voltage is 36 Volts.

6. Trash Collector (Arm):

Arm used here has total 3 mechanical movements. One circular movement which is use to rotate the full ARM, a linear movement to move the ARM vertically and a movement of gripper used to pick the object.

7. Power Supply:

Solar panel is used to power our project. The solar panel which we are using can produce output of 12 volts 10 watts. The output of solar panel is given to solar charger through diode to avoid back-current. Battery used here is of 12 volts and 1.2 Amps/hr.

5. CIRCUITRY:

Some of the system requirements of the project are listed below:

- ❑ Motor driver circuit is used for the motion of the robot.
- ❑ Power supply as to get sufficient power for the motor.
- ❑ The robot requires a motion controlling unit i.e. Raspberry Pi-3B with adapter.
- ❑ Metallic structure of the robot.
- ❑ Solar Panel and battery

6. DESIGN OF THE ROBOT:

A rectangle metal sheet of size 30 X 20 cm is taken as base of the robot. Four wheels are attached with geared motors to the base. The motors are of 10rpm each to move the bot to accurately detect the garbage. The mechanism of the bot has four which of are placed at an angle of 90 degrees from each other. The arm used to pick the garbage has 2 movements-one movement is vertical which is used to pick the garbage and second is circular movement which rotates the entire arm . For gripper one motor is used to close and open the gripper. Total 3 motor are used for movement of arm.



Figure -2 :Structure of Robot

7.IMAGE PROCESSING:

When it comes to deep learning-based object detection there are three primary object detection methods that you'll likely encounter:

- 1.Faster R-CNNs (Girshick et al., 2015)
- 2.You Only Look Once (YOLO) (Redmon and Farhadi, 2015)
- 3.Single Shot Detectors (SSDs) (Liu et al., 2015)

Faster R-CNNs are likely the most "heard of" method for object detection using deep learning; however, the technique can be difficult to understand , hard to implement, and challenging to train.

Furthermore, even with the "faster" implementation R-CNNs (where the "R" stands for "Region Proposal") the algorithm can be quite slow, on the order of 7 FPS.

If we are looking for pure speed then we tend to use YOLO as this algorithm is much faster, capable of processing 40-90 FPS on a Titan X GPU. The super fast variant of YOLO can even get up to 155 FPS.

The problem with YOLO is that it leaves much accuracy to be desired.

SSDs, originally developed by Google, are a balance between the two. The algorithm is more straightforward (and I would argue better explained in the original seminal paper) than Faster R-CNNs.

We can also enjoy a much faster FPS throughput than Girshick et al. at 22-46 FPS depending on which variant of the network we use. SSDs also tend to be more accurate than YOLO. To learn more about SSDs.

MobileNets: Efficient (deep) neural networks.

When building object detection networks we normally use an existing network architecture, such as VGG or ResNet, and then use it inside the object detection pipeline. The problem is that these network architectures can be very large in the order of 200-500MB.

The general idea behind depth wise separable convolution is to split convolution into two stages:

1.A 3×3 depthwise convolution.

2.Followed by a 1×1 pointwise convolution.

This allows us to actually reduce the number of parameters in our network.

The problem is that we sacrifice accuracy — MobileNets are normally not as accurate as their larger big brothers but they are much more resource efficient.

Combining MobileNets and Single Shot Detectors for fast, efficient deep-learning based object detection. If we combine both the MobileNet architecture and the Single Shot Detector (SSD) framework, we arrive at a fast, efficient deep learning-based method to object detection. The model we'll be using is a Caffe version of the original TensorFlow. The MobileNet SSD was first trained on the COCO dataset (Common Objects in Context) and was then fine-tuned on PASCAL VOC reaching 72.7% mAP

(mean average precision). We can therefore detect 20 objects in images (+1 for the background class), including airplanes, bicycles, birds, boats, bottles, buses, cars, cats, chairs, cows, dining tables, dogs, horses, motorbikes, people, potted plants, sheep, sofas, trains, and tv monitors.

With help of Image processing we distinguished animals from other objects. So any obstacle which is not detected as animal will be picked.

8.FLOW CHART

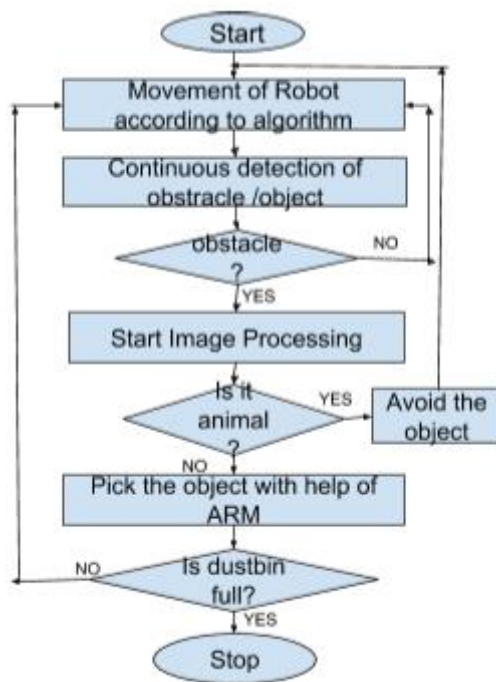

Figure -3 :Algorithm

The illustration of algorithm(Figure 3) is as follows:

The project starts and then the movement of the robot takes place according to the algorithm. There is continuous detection of the obstacle. If the obstacle is detected then the image processing is turn on and if the obstacle is not detected then the movement of the robot again takes place according to the algorithm. As the image processing starts it detects whether it is animal or not. If animal is detected then it avoids the object and again the movement of robot according to the algorithm takes place. If animal is not detected then it is considered as garbage and then it picks the object with help of arm. This process is repeated every time it detects an object until the dustbin is full. When the dustbin gets full it stops and if the dustbin is not full it repeats the process until the dustbin gets full.

9.RESULTS

The objective of the project was achieved to some extent. The garbage collected efficiently and effectively. Image Processing successfully distinguished between the robot moves in a constant speed. The garbage gets detected when it is at 20 cm from the trash. The project is still in progress to achieve the optimised results with few more modifications.

10. CONCLUSIONS

The Garbage and recycling pickup work is physically demanding and it exposes workers to many occupational hazards. This project is designed to fulfil the task of collecting garbage from certain places. To build an automatic trash robot using Raspberry Pi.

REFERENCES

- [1] G. Sivasankar, B. Durgalakshmi and K .Seyatha, "Autonomous Trash Collecting Robot",Published by International Journal of Engineering Research & Technology (IJERT),April 2017.
- [2] Saravana Kannan G, Sasi Kumar S, Ragavan R, Balakrishnan M,"Automatic Garbage Separation Robot Using Image Processing Technique", International Journal of Scientific and Research Publications, Volume 6, Issue 4, April 2016.
- [3] Osiany Nurlansa, Dewi Anisa Istiqomah, Mahendra Astu Sanggha Pawitra, Member, IACSIT "AGATOR (Automatic Garbage Collector) as Automatic Garbage Collector Robot Model" International Journal of Future Computer and Communication, Vol. 3, No. 5, October 2014.