

RADIOSONDE PAYLOAD FOR WEATHER BALLOONS

Shubham Wankhade¹, Anushri Kher², Komal Rawate³, Mrs. M.A.Kango⁴

^{1,2,3,4} Dept. of Electronics & Telecommunication Engineering, PES's Modern College, Pune, India

⁵ Professor at Dept. of Electronics & Telecommunication Engineering, PES's Modern College, Pune, India

Abstract – Aim of this project is to design a reliable embedded system which will be used for measuring , temperature ,pressure and humidity in the atmosphere for up to date weather monitoring. Weather is monitored at different levels of the atmosphere, by using a hydrogen balloon based payloads in which temperature, pressure and humidity sensors are embedded along with GPS receiver to send longitude–latitude coordinates of location and to measure wind speed .These measured values are then transmitted to the ground station for forecast and analysis. Radio frequency signals are used for communication between ground station and balloon floating station (space station) respectively along with GSM module to send location on mobile in order to increase the reliability of the project. Radiosonde data are valuable resource in the detection of climate change in the upper atmosphere. Long time series of stratospheric temperature data, carefully screened and corrected to remove errors, are available for this purpose. Normal reporting practice usually ascribes a fixed time and position (the station location) to all data reported in the ascent. In reality, the ascent may take around 90 min to complete and the spatial drift of the radiosonde may exceed 200 km.

Key Words: Radiosonde; longitude–latitude coordinates; Payload; Stratosphere; Altitude; Space Station;

1.INTRODUCTION

Weather is the state of the atmosphere at any given time and place it takes place in the lower layer of the atmosphere. Weather occurs because our atmosphere is in constant motion. Some determining factors of weather are temperature, pressure, humidity, precipitation, fronts, clouds and wind. Other more severe weather conditions are hurricanes, tornadoes, and thunderstorms. Weather changes every season because of the Earth's tilt when it revolves around the sun. The radiosonde is a balloon-borne instrument platform with radio transmitting capabilities. It also named as radio- meteorograph. The radiosonde contains sensors capable of making direct real-time measurements of air temperature, humidity and pressure with height , typically to altitudes of approximately 30 km. These observed data are transmitted immediately to the ground station by a radio transmitter located within the instrument package.

2. EXISTING SYSTEM

Meteorology is the study of weather and meteorologists are scientists who study and predict weather. At present, the

Indian meteorological department measures the practical weather (temperature, pressure, humidity wind direction etc.) by using hydrogen balloons. In order to measure the practical weather, they have to send hydrogen filled balloons every day at 0.00 and 12.00 UTC . The equipments are placed outside the hydrogen filled balloon and sent in the atmosphere for measuring weather. Meteorology provide information regarding the vertical structure of the atmosphere which is ingested into numerical weather prediction models. The Sonde or 'radiosonde' refers to the instrument package. 'sounding' is normally used for the entire sonde balloon launch and the data collected by a launch. [1] A meteorological balloon , carrying instruments and transmitting equipment is re-released, untethered, rises until it bursts, and falls back using a parachute. The radiosonde transmits GPS data to a radio receiver so that the payload can be recovered. The radiosonde contains sensors capable of making direct real-time measurements of air temperature, humidity and pressure with height. Payload used by Meteorological departments can only recovered by searching the landing location of payloads this procedure is time consuming. In the research paper of Andreas Karuchi and Rolf Philipona , Return Glider Radiosonde (RGR) is used .The RGR is lifted with weather balloons similar to traditional radiosondes to a preset altitude, at which time a release mechanism cuts the tether string, and a built-in autopilot flies the glider autonomously back to the launch site or a desired pre-programmed location.

3.PROPOSED SYSTEM

In this GSM module is connected to the GSM mobile phone network. Models vary but typically you call to the number of the SIM card in the device, and if they are programmed using AT commands then it texts you back the input data or they automatically sends data at definite time of intervals .These are cheap and simple device. We used long range 865Mhz Transmitter and receiver for radio communication between payload to base station .We look for APRS(Automated Packet Reporting System). This is an Amateur Radio system which is used to track balloons, but there are two restrictions. First, airborne amateur radio is not allowed in all countries. And second is, you have to have an appropriate amateur radio license.[2] And also look for LoRa(Long Range wireless data telemetry) it relates to a radical VHF/UHF 2-way wireless spread spectrum data modulation approach that has recently been developed & trademarked (™) by Semtech - a long established (1960) US multinational electronics firm. This technology developed by

Cycleo, a French company acquired by Semtech in 2012. LoRa™ is proprietary, but it appears to use some sort of "simpler" CSS (Chirp Spread Spectrum) pulsed FM "sweeping frequency" modulation rather than DSSS (Direct Sequence SS) or FHSS (Frequency Hopping SS). It is used for long range data transmission.^[3]

3.1. PROPOSED SYSTEM SPECIFICATIONS

- Operating Voltage: 5V
- Operating Current: 40mA
- Temperature Sensitivity: -55 To 150°C
- Humidity: 0 To 100%
- Air Pressure: 300 To 1000Hpa

Transceiver

- Operating voltage: 2.3 to 3.6V
- Rx/Tx Turnaround Time: 152µs
- Maximum Radio Data rate: 250kbps
- Operating frequency: 865MHz
- Modulation Scheme: FSK

3.2. BLOCK DIAGRAM AND DESCRIPTION

3.2.1. TRANSMITTER

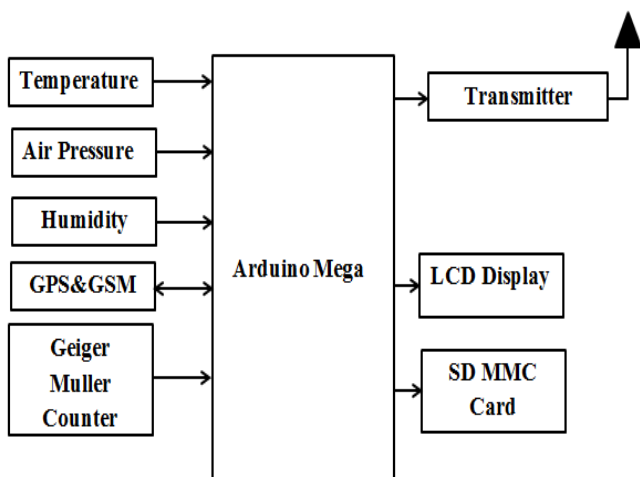

Fig -1: Transmitter

I. Arduino Mega :

The Arduino Mega 2560 is a microcontroller board based on the ATmega2560. It has 54 digital input/output pins, 16 analog inputs, 4 UARTs (hardware serial ports), a 16 MHz crystal oscillator, a USB connection, a power jack, an ICSP header, and a reset button. Used to control and process the data.

II. TEMPERATURE SENSOR :

The LM35 series is precision integrated-circuit temperature sensor with an output voltage linearly proportional to the Centigrade temperature over a full -55°C to 150°C temperature range. This sensor is connected to the analog pin of Arduino Mega.

III. AIR PRESSURE SENSOR :

BMP280 is precision sensor from Bosch used for measuring barometric pressure and temperature.

IV. HUMIDITY SENSOR DH22 :

The DHT22 is a basic, low-cost digital temperature and humidity sensor. It uses a capacitive humidity sensor and a thermistor to measure the surrounding air, and spits out a digital signal on the data pin.

V. GPS/GSM MODULE:

The SIM808 GSM GPRS Module is an integrated cellular (GSM/GPRS) module. GPS receives data using NMEA 0183 protocol. NMEA (National Marine Electronics Association) strings are received in human readable format. This string is further parsed using Arduino microcontroller. GSM receives data in the form of AT Commands from Arduino Mega. This data is transmitted to the registered mobile number at definite programmed time intervals.

VI. Geiger Muller Counter :

Geiger Muller Counter is a circuit which produces pulses when ionizing radiation such as α , β and γ is encountered on the Geiger Muller Tube. It uses Townsend avalanche phenomenon to produce an easily detectable electronic pulse from as little as single ionizing event due to a radiation particle.

VII. LCD Display:

Display used is 16x2 LCD display. It operates on 4-bit mode in order to save the pins of Arduino and displays data on the screen.

VIII. SD MMC CARD:

It is used to store data in csv (Comma Separated Value) format. It is interfaced with Arduino Mega using SPI protocol.

IX. Transceiver:

RDM-UART-A8FZ-LR is a transceiver module used to transmit data from payload to the ground base station. It uses FSK modulation scheme at bit rate of 250Kbps at the frequency of 868 MHz.

3.2.2. RECEIVER

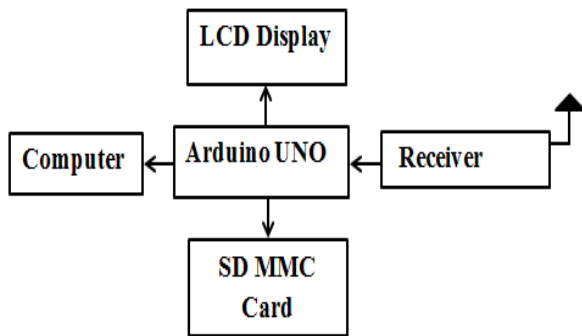

Fig -2: Receiver

I. Arduino Uno :

The Arduino Uno is a microcontroller board based on the ATmega38 .It has 14 digital input/output pins which can be used as PWM outputs, 6 analog inputs, 1 UARTs (hardware serial ports), a 16 MHz crystal oscillator, a USB connection, a power jack, an ICSP header, and a reset button. Used to control and process the data.

II. LCD Display:

Display used is 16x2 LCD display. It operates on 4-bit mode in order to save the pins of Arduino and displays data on the screen.

III. SD MMC CARD:

It is used to store data in csv (Comma Separated Value) format .It is interfaced with Arduino Uno using SPI protocol .

IV. Transceiver:

RDM-UART-A8FZ-LR is a transceiver module used to receive data from payload to the ground base station. It uses FSK modulation scheme at bit rate of 250Kbps at the frequency of 865 MHz.

V. Computer:

It is used for graphical representation of the weather data and plot the flight path on Google earth.

3.3.HARDWARE SYSTEM DESIGN

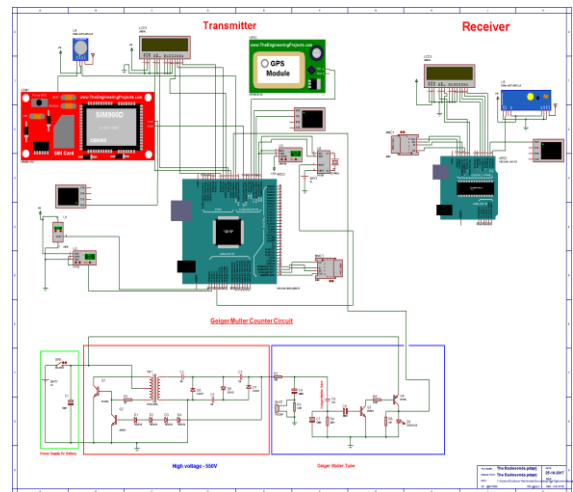

Fig -3: Hardware System

Radiosonde Circuit:

The schematics of Radiosonde are shown in above figure. Following points will give the details of the schematics.

3.3.1 Transmitter:

+5V is applied to the circuit to drive the components such as Arduino board, sensors, displays, etc.

- Temperature sensor :LM35 is used to measure temperature from -55 to -150 °C .Pin 1 of LM35 is connected to +5V, pin 3 is connected to the ground and pin 2 is connected to A0 of analog pins of the Arduino board .
- Humidity sensor:DH22 has 4 pins. Pin 1 is connected to +5V, pin 4 is connected to ground ,pin 2 is connected to digital pin no .9 of Arduino board.
- Air pressure sensor :BMP180 is a air pressure sensor used to measure the air pressure from 300hpa to 1000pa .Pin 3 of BMP180 is connected to +3.3V .Pin no. 5(SCL) & 6(SDA) are connected to pins 21 & 20 i.e., SCL and SDA of Arduino.
- Geiger Muller Counter :It is given to buzzer which produces sound proportional to ionizing radiation and output is given to pin 2(Int4) of Arduino Mega board.
- GPS module: Tx pin of GPS module is connected to pin 17(Rx2) of arduino.
- GSM (SIM900a) Module :-Rx pin of GSM (SIM900a) is connected to pin 14(Tx2) of arduino board. Tx

pin of GSM module is given to Rx pin of Virtual Terminal.

- SD MMC Card : SD MMC Card is connected to arduino through SPI pins 50(MISO) to MOSI,51(MOSI)to MISO,52(CLK) to CLK and pin 53(SS) to SS pins of SD MMC Card.
- LCD Display :LCD pins VSS, VEE, R/W,D₀ to D₃ are connected to ground .VDD is connected to +5V. Data pins D₄ to D₇ are connected to digital pins 5 to pin 8. RS pin is connected to pin 3 and E (enable) to pin 4.
- Transceiver : RDM-UART-A8FZ-LR is a transceiver used to transmit data to the base station. GND and VCC pins are connected to +5V and Ground of arduino .DATA pin is connected to pin 1 (Tx0) .
- Virtual Terminal :- Tx and Rx pins of Virtual Terminal are connected to pin 19 (Rx1) and pin 18 (Tx1)

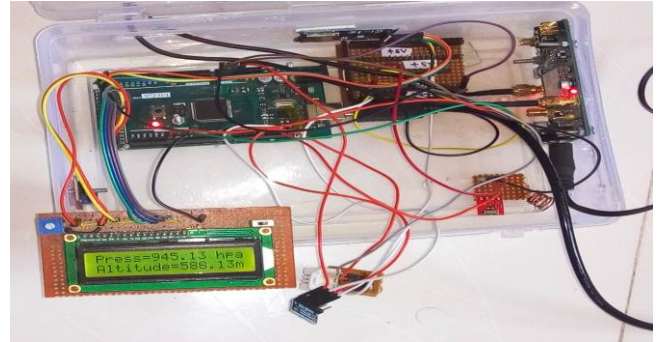

Fig.5 Radiosonde - Transmitter Circuit

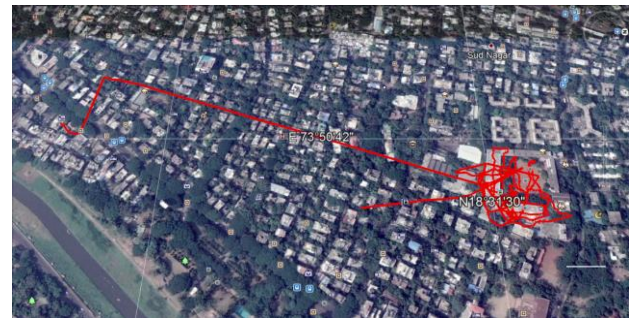

Fig.6 Radiosonde Flight Path

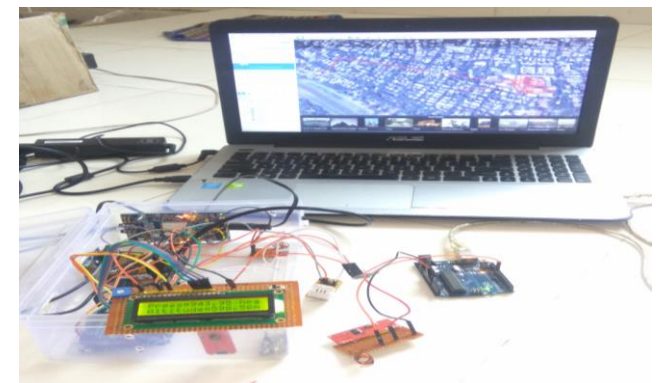

Fig.7 Radiosonde Receiver Circuit

Altitude (m)	Temperature (°C)	Air Pressure (hpa)	Humidity (%)	Date	Latitude (deg)	Longitude (deg)	Altitude (m)	Speedfrom GPS (Kmph)	Distance to Pune (Km)	Course (deg)	Cardinal (N-S-E-W)
589.57	33.38	945.06	28.50	****	*****	*****	*****	*****	*****	*****	*****
589.12	33.38	945.02	28.50	16	18.526447	73.826362	579.60	0.31	3	104.44	EE
589.76	33.37	945.06	28.10	17	18.526653	73.826370	579.60	0.39	3	104.45	EE
589.08	33.35	945.03	28.20	17	18.526657	73.826370	579.70	1.02	3	104.46	EE
589.16	33.36	945.02	28.10	17	18.526674	73.826332	579.70	0.67	3	104.48	EE
589.12	33.34	945.02	28.20	16	18.526676	73.826316	579.70	0.15	3	104.47	EE
589.22	33.32	945.01	28.30	15	18.526679	73.826316	579.70	0.30	3	104.48	EE
589.95	33.36	945.04	28.30	15	18.526679	73.826316	579.70	0.59	3	104.48	EE
589.92	33.38	945.04	28.30	17	18.526683	73.826347	579.60	1.20	3	104.50	EE
589.03	33.34	945.03	28.40	17	18.526697	73.826377	579.30	0.13	3	104.54	EE
589.21	33.33	945.01	28.50	17	18.526699	73.826370	579.30	0.26	3	104.55	EE
589.97	33.34	945.04	28.40	17	18.526687	73.826347	579.30	0.74	3	104.51	EE
589.56	33.32	944.97	28.50	17	18.526685	73.826339	579.30	0.30	3	104.50	EE
589.80	33.31	944.94	28.50	16	18.526699	73.826347	579.30	0.48	3	104.53	EE
589.34	33.34	945.00	28.50	17	18.526714	73.826339	579.30	0.33	3	104.55	EE
589.91	33.34	944.94	28.60	17	18.526723	73.826354	579.30	1.00	3	104.58	EE
589.80	33.35	944.94	28.60	17	18.526725	73.826377	579.30	0.15	3	104.60	EE
590.08	33.35	944.91	28.60	16	18.526725	73.826385	579.30	0.56	3	104.60	EE
589.92	33.34	944.93	28.70	16	18.526721	73.826400	579.30	0.78	3	104.60	EE
590.09	33.34	944.91	28.70	17	18.526714	73.826423	579.40	1.26	3	104.59	EE
590.34	33.34	944.88	28.70	17	18.526737	73.826477	579.40	1.31	3	104.67	EE
590.06	33.34	944.91	28.80	17	18.526710	73.826499	579.40	0.70	3	104.64	EE
589.99	33.36	944.96	28.90	17	18.526697	73.826489	579.40	0.63	3	104.60	EE
590.04	33.33	944.92	28.90	17	18.526695	73.826484	579.40	0.26	3	104.59	EE

Fig.8 Radiosonde - Received Data

RESULTS

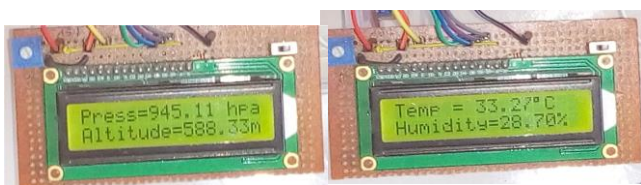

Fig.4 Radiosonde-Lcd Output

CONCLUSIONS

Weather is the state of the atmosphere at any given time and place. At present, the main factor in measuring weather conditions is cost and also reliability. In this project, the different kinds of atmospheric weather conditions will be measured by using hydrogen balloon with temperature sensor, pressure sensor and humidity sensor. Geiger Muller Counter will help to study the effect of Cosmic noise and ionizing radiation on the communication system.

The Communication will carry out by radio frequency from the space station to the ground station. The work was carried out for implementing this system in our college premises. Further, calibration of sensor weather data and storage of the data is to be done & time stamping. Also new communication methods will be adopted. Radiosonde is a very cheap and low cost device and his very useful for wireless data transmission and weather forecasting.

ACKNOWLEDGEMENT

We would like to express my special thanks of gratitude to my guide Mrs. M. A. Kango who gave me the golden opportunity to do this wonderful project on the topic i.e. "RADIOSONDE FOR PAYLOAD OF WEATHER BALLOONS", which also helped me doing a lot of research and came to know about new things.

We would also like to express a deep sense of gratitude and regards to Mrs. V. K. Roate of Physics Department of P.E.S's Modern College of Engineering and Mr. Manish R. Ranalkar of Indian Meteorological Department along with Mr. T. C. Mohadikar of Agricultural Meteorology Department. And lastly we would also like to David Peterson, Assistant Professor, Electronics/Robotics and Centralia College, Washington DC, USA who provide valuable information and guidance to us.

REFERENCES

- [1] Andreas Karuchi, Rolf Philipona, Gonzague Romanens, Dale F. Hurst, Emrys G. Hall and Allen F. Jordan "Controlled weather balloon ascents and descents for atmospheric research and climate monitoring" Atmos. Meas. Tech, European Geosciences Union, 3 December 2015.
- [2] Andreas Karuchi, Rolf Philipona "Return glider radiosonde for in situ upper-air research measurements" Atmos. Meas.Tech, European Geosciences Union, 9 June 2016
- [3] David J.S.(2013)Microbes inUpper Atmosphere and Unique opportunities for Astrobiology Research.Astrobiology.13(10):981-990
- [4] Janet Tate, William Schoenfeld "Creation Of Western Oregon University Weather Ballooning Program: GPS

Tracking ,Heating Circuitry, and Balloon Filling Procedure" Department of Physics Oregon State University.

- [5] Nayak A..Sreesith A.G.Safonola M.Murthy j.,(2013) High altitude ballooning Programme at Indian Institute of Astrophysics current Science,104:708-713
- [6] P. Sankar , Suresh. R. Norman "Embedded system for monitoring atmospheric weather conditions using weather balloon", IEEE Control, Automation, Communication and Energy Conservation, 2009, 18 August 2009.
- [7] Srejith A.G. ,Nayak A. Murthy J.(2012) Baloon Observations at the Indian Institte of Atrophysucs 39th COSPAR Sciientific Assembly,Aug 2012,Mysore,India-TFs-C-057PsB.1-00043-12,CoSpaR Abstract.Book,P.234