

# SOLAR POWER BASED REMOTE MONITORING AND CONTROL OF INDUSTRIAL PARAMETERS USING IoT

S. Madhubala<sup>1</sup>, R. Nachammai<sup>2</sup>, I. Nandhini<sup>3</sup>, A. M.Preethisha<sup>4</sup>, J. Janet Paulin<sup>5</sup>

<sup>1,2,3,4</sup> UG Student, Department of Electronics and Instrumentation Engineering, National Engineering College, K.R.Nagar, Kovilpatti- 628503, Tamilnadu.

<sup>5</sup> Assistant Professor, Department of Electronics and Instrumentation Engineering, National Engineering College, K.R.Nagar, Kovilpatti- 628503, Tamilnadu.

\*\*\*

**Abstract** - The main aim of our project is to develop a system for remote monitoring and control of vital industrial parameters such as measurement of gas, speed, temperature, pressure, current and voltage for diagnosis, prevention of human fatalities, extension of life of machinery, automated range based access and two way control using green technology in a friendly and secure manner using internet and biometrics. The current scenario in industry envisages safety and automation hand in hand. This starts with monitoring effectively, efficiently and constantly. Such systems in earlier models were done manually leading to errors resulting in loss of lives as well. The proposed model enables continuous monitoring of essential parameters along with storage. This enables automated decisions based on the ranges of the monitored parameters. If the temperature exceeds its threshold then the cooling fan is automatically switched on, an alert is sent to the user and also in case of an explosion or fire or leakage of gas inside the unit, sends an automated alerts and emergency notifications to the fire rescue team, owner, in charge etc., along with location shown in Google maps. This also evacuates the personnel both inside and in nearby areas to reduce loss of life and equipment. On the server side it enables a biometric based access as a security measure to both access and control the parameters. Solar power based remote monitoring and control of industrial parameters using IoT enables the user to control the parameters anywhere at anytime such that the system should be working continuously.

**Key Words** :Industrial automation system, Sensors, PIC microcontroller, Internet of Things(IoT), Remote control.

## 1. INTRODUCTION

### 1.1 Overview:

To increase the manufacturing and process plant availability, Remote Monitoring and Control is one of the most significant and essential criteria. There is lot of necessity for industrial monitoring system. Industrial System should be able to acquire, store, analyze, and process the real time data. It is also required to control the process parameters to transform related environmental factors and monitoring in long distance so that it realizes an accurate control. We can attain these reward by employing PIC16F877a microcontroller along with IoT.

Internet of Things is the big revolt of the world on digitalization of commercializing various modules/products[7]. Everything is associated with the internet, some involve controlling and some incorporates monitoring the parameters from anywhere. The Internet of Things (IoT) is the network of physical objects or "things" embedded with electronics, software, sensors and connectivity to enable it to realize greater value and service by exchanging data with the manufacturer, operator or other connected devices[7]. Each thing is uniquely identifiable through its embedded computing system but is able to interoperate within the existing Internet transportation. This enables everybody an reasonable and protected way to control their machines from any smart mobile device or internet correction.

### 1.2 Advantages of proposed system:

- Monitoring and measuring are done wirelessly and remotely
- Does not require human intervention hence accurate and stored in web database
- Automated decision making based on the ranges of the parameters
- In case of a fire or gas mishap the data does not get destroyed
- Loss of life due to injury can be prevented.
- Exact location is made known to enable quick access to rescue teams using google maps.
- Two way Control mechanism is provided
- Graphs are generated for analysis of units and recurrence of future conditions.
- Since solar models are used less energy is consumed for monitoring and measuring purpose.
- Biometric Security is implemented for grating proper access to measured data and control.

## 2. LITERATURE SURVEY

**Vinaysagar K N, Kusuma S M [1]:** In this paper they present a Home Automation system(HAS) using Intel Galileo that employs the integration of cloud networking, wireless communication, to provide the user with remote

control of various lights, fans, and appliances within their home and storing the data in the cloud. The system will automatically change on the basis of sensors' data. This system is designed to be low cost and expandable allowing a variety of devices to be controlled.

**Vishwajeet H. Bhide [2]:** In this paper we will see how to provide fully smart environment condition monitoring by various sensors (Temperature, Humidity, Light and Level) for providing necessary data to automatically adjust the comfort level in homes by optimize use of energy. They also used prediction here for automatic detection and resolution of any problem in the devices. For that they were using Naïve Bayes Classifier algorithm for data mining. It will send email or SMS to required technician for service and it will also notify the owner. This gives a huge advantage on the smart home systems using IoT.

**Elizabeth Kadiyala, ShravyaMeda and RevathiBasani[3]:** This paper surveys on Global industrial process monitoring through IoT. It is a system that uses computer or mobile devices to monitor functions in industry. It is intended to spare electric force and human vitality. The sensors that can be checked are temperature, light intensity, water level, current and voltage. These sensors are associated with Atmega and interface with Raspberry pi and observed qualities are put away in cloud. The modern procedure monitoring system varied from other system by permitting the client to work the system from any place around the globe through internet association. The system will consequently change on the base of the sensors information.

**Wen-Tsai sung , juihochan and ming- hantsai [4]:** In this paper a number of ZigBee based monitoring systems are built on the basis of IOT technology in this work on the perception layer, using temperature/humidity sensors, light sensors and 3-axis accelerometer modules. Wirelessly transmitted to a monitoring center, all the sensed data are collected by a human computer interface. On the application layer in an IOT, simulation experiments are conducted, namely, applications of light sensors to an automated basketball court lighting system, 3-axis accelerometer modules to the monitoring of infant's sleeping posture and accidental fall of the elderly, and temperature/humidity sensors to thermal comfort testing. This research work is validated as an effective way to achieve the aim of power consumption reduction, improve the health care quality and provide a higher comfort level.

**Prianka Agrawal and Gaurav Chitranshi[5]:** This paper introduces the design of web server using internet of things based on ATmega328 and Ethernet Shield W5100 Ethernet controller chip with some I/O devices. To create an HTML webpage for that it need an IP address of Server side and enter into the browser like Internet Browser, Firefox and Google Chrome at client side. Input/output devices are LM35 temperature sensor, Rain sensor, BMP180 pressure. Temperature, Pressure, Altitude and

Rain conditions are monitored and a system is developed and tested wherein in emergency situation various devices are controlled in real time.

### 3. PROPOSED METHODOLOGY

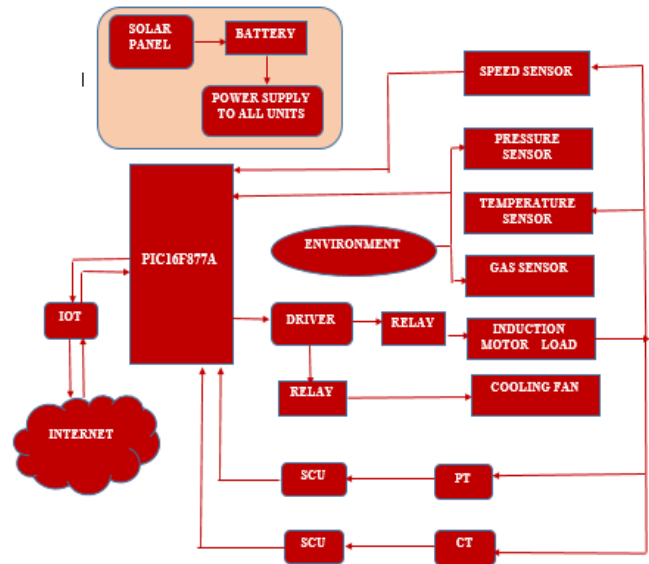

Fig-1: Block diagram of Hardware design

The proposed model of solar power based remote monitoring and control of industrial parameters using IoT is as shown in fig-1 and fig-2. The block of fig-1 shows hardware part of the model which consist of various sensors such as temperature ,gas, speed, current, voltage and pressure .PIC16f877a is a microcontroller used to take control actions in proportion to the change in values of the parameters. The various process parameters are being measured by the appropriate sensors are given to the controller from which the values are transferred to the IoT module where it sends the obtained data to the cloud.

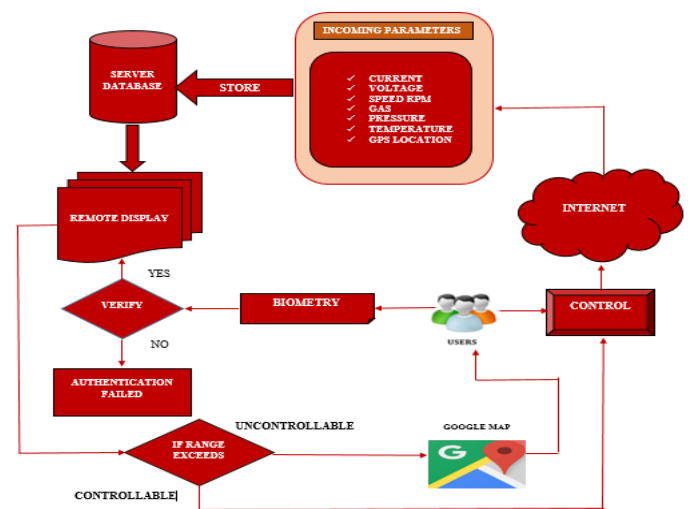

Fig-2: Block diagram of Software design

The fig-2 shows the software part of the design .cloud is a storage place where the user can view the measured parameters by a software known as cayenne..Here, the user can also control the parameters remotely by providing command through the software. The user can only access the parameters only that the concerned person is authenticated to do so. If not then the authentication is declined and the personal cannot access the parameters. If in case of any gas mishap an alert message along with the location where the incident has happened is sent to the recognised person to take actions.

**4. HARDWARE COMPONENTS**

**4.1 Temperature sensor**

The LM35 temperature sensor is used to sense the temperature of the induction motor which acts as a load. If the temperature exceeds its limit then the 12v DC cooling fan is automatically turned ON to drop the temperature of the load.

**4.2 Pressure sensor**

The air pressure sensor is used to measure the pressure in an environment and the output in ranges of mv is sent to the analog pin of the controller.

**4.3 Proximity sensor**

The speed of the induction motor is given as a pulse of input to the controller which counts the pulse because proximity is a type of digital sensor.

**4.3 Gas sensor**

MQ-2 is a type of gas sensor which is used to detect the leakage of gases in industry .various gases such as hydrogen, helium, LPG and smokes and alcohols can be detected by this sensor.

**4.4 Current transformer**

CT is used to measure the current taken by the induction load in which the underlying principle is by passing a thread of wire whose current is to be measured to a donut shaped device a proportional current or voltage proportional to the current can be measured by the device.

**4.5 Potential transformer**

Transformers (sometimes called "voltage transformers") are the devices used in electrical circuits to change the voltage of electricity flowing in the circuit.Hence it is used as a stepdown transformer to measure the voltage from the load and give it to controller where signal conditioning circuit is normally preferred.

**4.6 PIC16F877a Microcontroller**

It is a 40 pin chip with built in memory, timers and counters ,interrupts and works with the oscillator frequency of 20 MHz and consist of 10-Bit ADC with 5 ports with provision for LCD display. The operating

voltage which ranges about (2.0 to 5.5v).the sensors are connected to the analog pin of the controller where the registers play a key role in performing the task.

**4.7 Relay and Driver circuit**

ULN2003 is a driver used to switch over the speed of the induction motor from high, normal to low speed by automatically turning ON of the respective relays connected to different resistors.

**4.8 Induction motor**

A 1 $\phi$  ,100w,1.3Amp Induction motor used here acts as a load from which various parameters are measured and controlled effectively.

**4.9 IoT module**

ESP- 8266 is an IoT module used to transfer the parameters from the controller to the cloud storage where the user can access the values of the units and can also provide command to control the units through the software remotely.

**4.10 LCD display**

The user can also view the parameters measured by the sensors on the spot itself through 16x2 LCD display which display a maximum of 32 characters.

**4.11 Solar panel and Batteries**

A 12v,20w solar panel is used to acquire charge from suns radiation and a lead acid rechargeable batteries are used to store the charge in the panel which is provided as a power supply to all the components used in the system.

**5. SOFTWARE USED**

- MP lab IDE
- Arduino
- Proteus
- Cayenne

**6. RESULT**

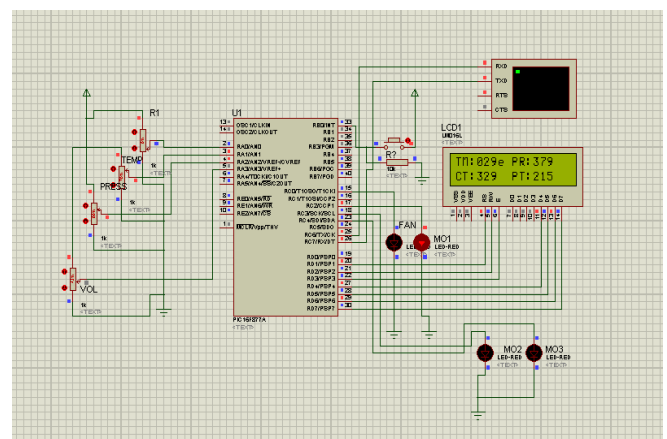

**Fig-3: Simulation of proposed model in proteus software**

The Fig-3 shows the proposed model in the software known as proteus is an effective way to run the code and check the output of the model in simulation. In this figure the LCD displays the values of the various parameters and it also shows the speed at which the induction motor(load) is running presently.

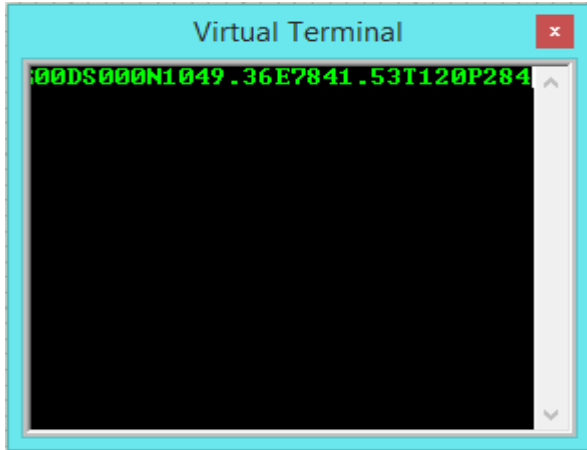

Fig-4: Output in virtual terminal of proteus

The fig-4 shows the values of the parameters along with the latitude and longitudinal location of the present location.

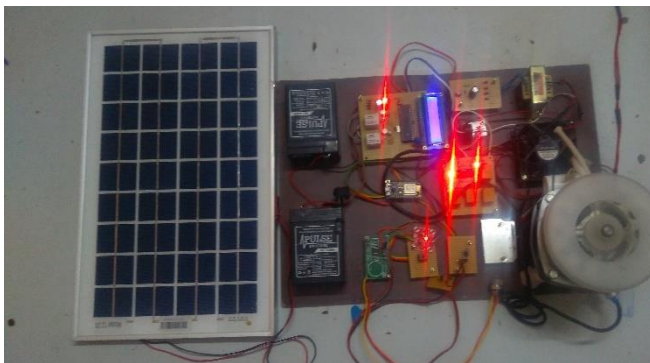

Fig-5: Experimental setup of proposed model

The fig-5 shows the proposed model of a systems in which the solar panel is connected to the hardware part of the model.

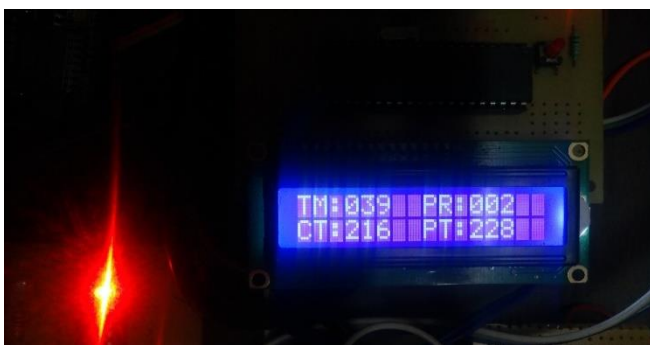

Fig-6: Values of parameters displayed in LCD

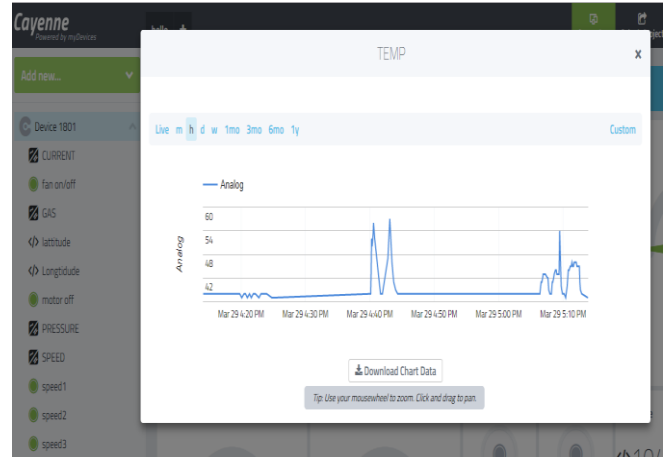

Fig-7: Graphical representation of temperature in cayenne

The fig-7 shows the graphical representation of one of the parameters i.e., temperature in cayenne software. Hence the values which obtained for the past 1year can also be displayed for further verification and the purpose of analysis in this software.

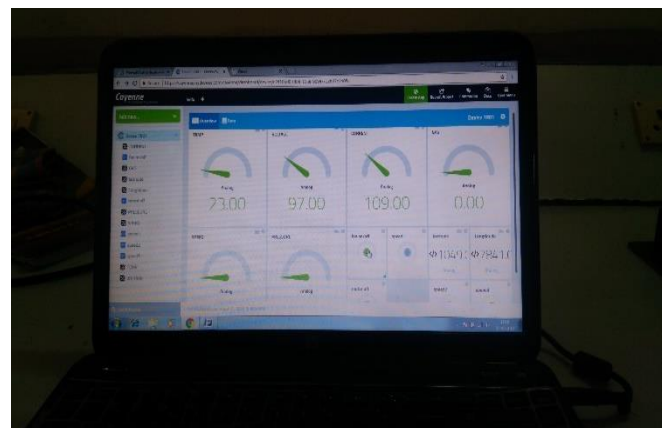

Fig-8: values of parameters shown in cayenne

	A	B	C	D	E	F	G
1	v	ts	unit				
2	39.93548	2018-03-2	null				
3	28.6	2018-03-2	null				
4	201.3333	2018-03-2	null				
5	122.7195	2018-03-2	null				
6	83.96703	2018-03-2	null				
7	138.24	2018-03-2	null				
8	1	2018-03-1	null				
9	142.25	2018-03-1	null				
10	209.5143	2018-02-1	null				
11	145.68	2018-02-1	null				
12	230	2018-02-1	null				
13							
14							

Fig-9 : Values obtained from the chart when the system is in working mode.

The graphical chart data can also be downloaded to view the values of parameters in Excel sheet as shown in fig-9.



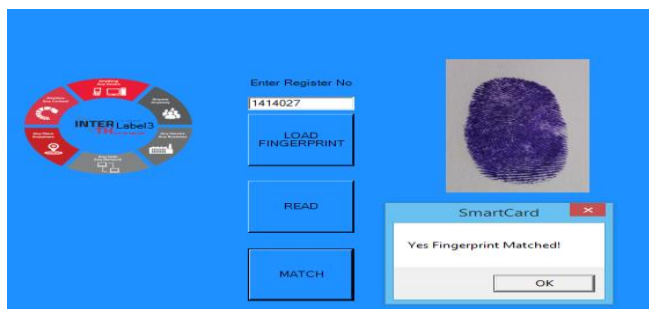

Fig-10.1: Biometry system employed in the model

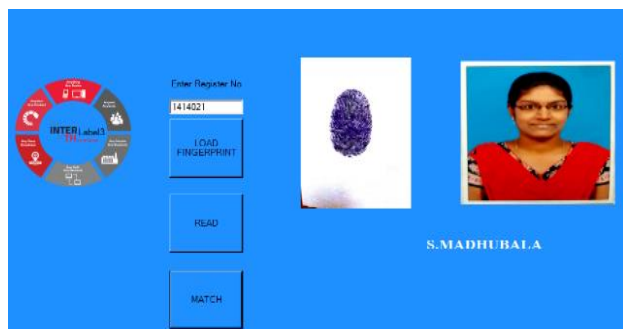

Fig-10.2: System providing access to a concerned Person

The fig 10.1 and 10.2 shows the biometrical access to the user to view the values of parameters in the software.

## 7. CONCLUSION

Thus the objective of solar power based remote monitoring and control of industrial parameters using IoT to measure various parameters such as temperature ,current ,pressure, voltage speed and the gas from the sensors and their output has been given to IoT module through PIC controller where the user can view the parameters which was measured by the device and similarly the user can control the device by providing the input to PIC controller through IoT module using cayenne software. Thus, by the effective implementation of the solar panel the sensors were smartly powered and the demand on electrical supply has been reduced greatly.

## 8. ACKNOWLEDGEMENT

We feel proud to pay our sincere gratitude and thanks to our respected project guide Ms. J. Janet Paulin, ME., Assistant Professor, Department of Electronics and Instrumentation Engineering, National Engineering College for her valuable Expert Guidance. We also thank her for useful suggestions, constant encouragement and kind advice in bringing out this project as a success. Her inspiration and systematic guidance have sharpened our abilities for a critical forward looking out of our project work.

## 9. REFERENCES

1. Vinay sagar K ,Kusuma S (2015) , “Home Automation Using Internet of Things”, International Research Journal of Engineering and Technology (IRJET),p-ISSN: 2395-0072 , Vol. 2 Issue. 3.
2. Vishwajeet H. Bhide (2014) , “A Survey on the Smart Homes using Internet of Things (IoT) “ , International Journal of Advanced Research in Computer Science and Management Studies (IJARCSMS), ISSN: 232 7782 (Online), Vol.2, Issue.12.
3. Elizabeth Kadiyala, ShravyaMeda, RevathiBasani (2017),“Global industrial process monitoring through IoT using Raspberry pi” , IEEE International Conference on Nextgen Electronic Technologies: Silicon to software (ICNETS2),DOI:10.1109/ICNETS2.2017.8067944
4. Applications of wireless sensor network for monitoring system based on IOT(2017) “ , 2016 IEEE International Conference on Systems, Man, and Cybernetics (SMC) ,DOI: 10.1109/SMC.2016.7844308
5. “Wireless sensor network for monitoring environmental factors in industrial installations(2016)”, 2015 CHILEAN Conference on Electrical, Electronics Engineering, Information and Communication Technologies (CHILECON) , DOI: 10.1109/Chilecon.2015.7404648
6. Internet of Things for monitoring the environmental parameters(2017), 2016 International Conference on Information Technology (InCITE) - The Next Generation IT Summit on the Theme - Internet of Things: Connect your Worlds, DOI: 10.1109/INCITE.2016.7857588
7. Review paper on IoT based technology(2017), International Research Journal of Engineering and Technology (IRJET), p-ISSN: 2395-0072, Vol. 4 Issue. 1.

## 10. BIOGRAPHIES



Ms.S.Madhubala pursuing B.E -Electronics and Instrumentaion Engineering at National Engineering College (NEC), Kovilpatti.



Ms.R.Nachammai,pursuing B.E - Electronics and Instrumentaion Engineering at NEC, Kovilpatti.



Ms.I.Nandhini, pursuing B.E-Electronics and Instrumentaion Engineering at NEC, Kovilpatti.



Ms.A.M.Preethisha, pursuing B.E-Electronics and Instrumentaion Engineering at NEC, Kovilpatti.