

# AUTOMATIC FOOTBRIDGE PLATFORM SYSTEM ON RAILWAY PLATFORM

Akshay Pardeshi<sup>1</sup>, Pavan Kumavat<sup>2</sup>, Vishal Mahajan<sup>3</sup>, Yashwant Patole<sup>4</sup>, Rajashree S. Kadam<sup>5</sup>

<sup>1234</sup> Diploma students, Department of Electrical Engineering, Guru Gobind Singh Polytechnic, Nashik Maharashtra, India

<sup>5</sup> Assistant Professor, Department of Electrical engineering, Guru Gobind Singh Polytechnic, Nasik, Maharashtra, India

\*\*\*

**Abstract** - The Primary objective of Automatic Railway Bridge System is to help the physically Challenged Passenger to move from one Platform to another. Crossing the railway track inside the railway station is very difficult. But it is quite difficult to the handicapped and aged persons to cross the railway track without the help of others. In this paper the agents make use of a set of resources train characteristics, driving rules and information about other trains to generate their action policy. There are many old peoples suffering from leg cramps walking difficulties leg vein problems and chronic foot pains etc. That's why to solve this problem we are making a solution for that is we are going to make a project on a horizontal adjusted platform which is connected between both stations platform. Because due to this there will be no need to climbing on a bridge by adults as well as children's. This will be time saving for passenger with a smoother operation going to experience by the people or by passengers.

**Keywords:** Global Navigation Satellite System (GNSS), Multi Aspect Signalling Systems (MASS), IR SENSOR (E18-D80NK Infrared Proximity Sensor), PLC, DC Motor.

## 1 INTRODUCTION

Indian railway network is the one of the biggest rail network in the Asia. Railways are recognized as a one of the safest mode of mass transportation and Safety has been recognized as the key issue for the railways networks. To make it a safe and reliable system is an enormous challenge. Unmanageable platform crossings are one of the problem areas for the Indian Railways, and one of the major issues of death. In spite of various measures taken by the Indian Railways, platform crossing deaths have continued to occur, that too frequently.

The short horizontal platform will be attached to both end of the two platforms by which we can adjust it after and before coming of train by moving or sliding them horizontally by the sensors and motor. The one part of the bar or platform is connected from first platform to second part of the bar will be moved or slide to the second platform very smoothly according to presence or absence of train. That will maintain the comfort ability of the peoples which will going to suffer from them.

## 1.1 Objective

- The main objective of our project is to reduce more electricity consumption. Due to this unwanted accident can be prevents.
- This also time saving much more than the other remaining techniques. as per the overall old system which is given below (escalators & bridges) are used for crossing platforms from one to another platform.
- That is very painful for in our Indian countries but escalator implication on per platform in India that is not possible because the less civilization as well as the cost and maintenance is more. Adults peoples can't get their trains because of being late due to the process of climbing on the bridges and due to kids too.

## 1.2 Problem Definition

- These are old technique to climb on bridge. Due to this we may goes too late for our upcoming train. Also due to electric bridge (escalator) more electricity required to drive the motor which is lives under the escalator.
- The uneducated person directly crosses the trains' routes. This may be dangerous for their life. Now, to overcome this problem, we prepared this project. By which the problem of more electricity consumption can be reduce to less.
- Due to this unwanted accident can be prevents. This also time saving much more than the other remaining techniques.



Fig No 1

that; as regular process peoples will cross there sliding platforms safely and gradually. Highest accuracy of the system will be there, because there is lack of time for closing and opening of Barra gates and the sliding platforms (s).

## 2 BLOCK DIAGRAM

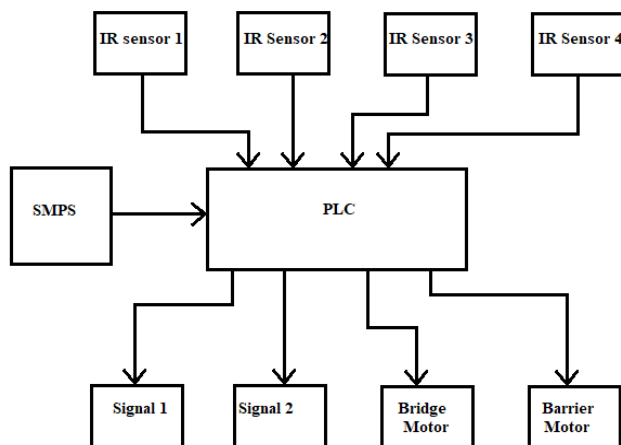

Fig No 2 Block Diagram of System

## 3 PROPOSED PLAN

AS per the given abstract the proposed plan or working will be same. As soon as there are two platforms in general i.e. platform 1 is 'a', and platform 2 is 'b' our siding platform is 's'. There will be having the availability of sliding platforms attached to per stationary platform. now whenever there will be no train on the platform this sliding platform is in close position, but when train is being coming or its at specific distance the controlling signal will be given to sliding platform and it will be going to opened before the coming the train. This is providence for the safety purpose of peoples who will be crossing the sliding platform. Along with the controlling signals, buzzers are also provided. We are going to maintain the more and more safety as well as reliability of our project. After the train departure, again the alert will be given and Barra gates of the sliding platforms will be opened after

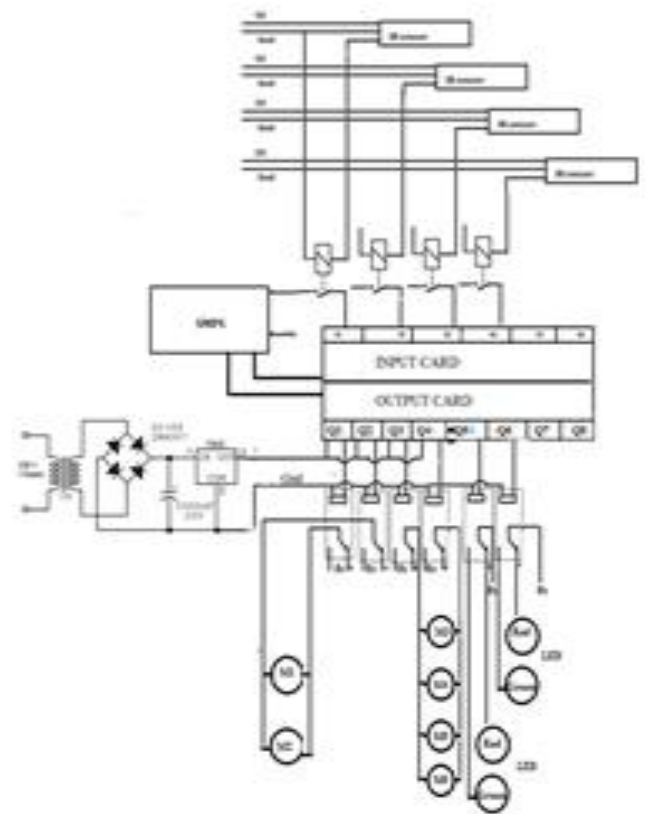

Fig No. 2 Schematic Diagram

### 3.1 IR SENSOR (E18-D80NK Infrared Proximity Sensor)

This Infrared Reflectance Sensor Module carries a single infrared LED and phototransistor pair in an inexpensive, tiny module that can be mounted almost anywhere and is great for obstacle detection of robot and home alert system. The optimal sensing distance is within 50cm (20 inches).

### 3.2 Schneider Logo PLC

The purpose of a PLC was to directly replace electromechanical relays as logic elements, substituting instead a solid digital computer with a stored program, able to emulate the interconnection of many relays to perform certain logical tasks. We have used the Schneider Logo plc. It is a software based instruments and hence it can be programmed using an easy-to-learn programming languages.

### 3.3 DC GEAR MOTOR

Gear motor is a combination of motor and gearbox. When users choose DC motor, they will find it cannot reach their requirement because of high speed or low torque, so gear motor is their best choice. Our micro DC gear motor uses standard DC motor. Diameter of gearbox is from 8 to 37mm, and gear sharp diameter includes 48mm and 58mm. Voltage is from 1.5V to 24V. Power is under 10W.

### 4 WORKING

When there will be no train being present there then, the footbridge will have been closed and peoples or senior citizen will cross it with all safety providence. When the train at the specific distance away from the platform then buzzer will sound for close Barricades at platform as well as the remaining peoples those who are standing on footbridge they will cross the platform and after that the footbridge tends to close because the train is coming on platform accordingly with all safety measures will have been done. After closing of footbridge signal will indicate the GREEN signal, so that train can proceed further. If any fault or problem occurs in system, footbridge will not open; incise of this signal will indicate the red light & train will stop. So there is no risk of any type of accident.

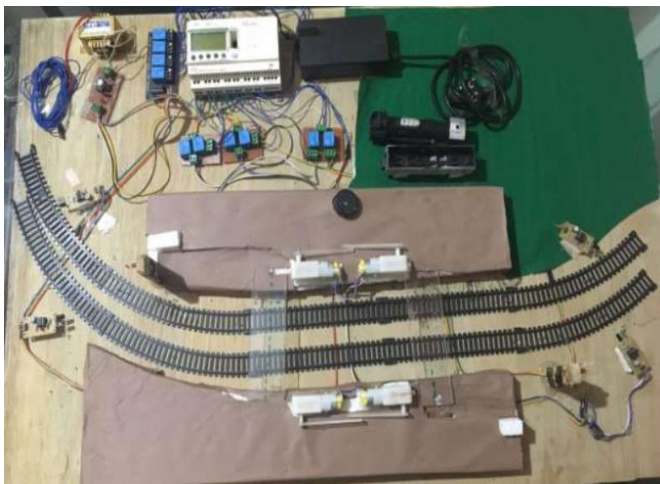

Fig No 3 Implemented System

This method helps in reducing the time and area requirement. Further in future we can make the bridge as a rotating one for the effortless crossing of railway track for disabled persons.



Fig No 4

### 5 APPLICATIONS

- Less power is used.
- The system is Simple, economic and compact.
- No need to climb bridges over platform to cross the track. There is no need of lift, elevator.
- Time saving.
- Less costly.
- If there is any fault in the system, then the system can be operating manually.

### 6 CONCLUSIONS

The aim of this paper was to develop a system that could help the disabled person to cross the railway platform in far easy manner. The main contributions this study has made were the establishment of driving rules to allow trains to travel economically while giving priority to safety; the inclusion of additional trains travelling in the same direction at a safe distance apart.

The project will save the energy comparatively to elevator, because of this project crossing of platform will be so easy. This project prevents the level of accidents. Peoples who have factures, leg cramps, chronic foot pains and etc. they also can cross the platform easily as well as it is also helpful for the senior citizens who have problem for crossing the platform by using the bridge.

### 7 FUTURE SCOPES

The modifications to be done in this project are in a new recognition method using stereo vision which calculates automatically volume of objects in bridge can be used. Moreover, we consider other dangerous factors, such as safety accidents as fall between a platform and a train, getting stuck between the bridges.

### ACKNOWLEDGEMENTS

Sincere thanks to all the anonymous researchers for providing such a useful and helpful opinion, findings, conclusions and recommendations. Also gives immense

pleasure to thanks to guide Ms. Rajashree Kadam, HOD Prof. Prof S M More, Principal Prof P S Duggal, and friends for their kind support and guidance.

## REFERENCES

1. Yoda,k. Sakaue "Ubiquitous Stereo Vision for Controlling Safety on Platform Railroad Station," IEEJ Tr. on Electronics, Information and Systems Vol.124, No.3, pp.805
2. The RUNE project "Navigation Performance of GNSS Based Railway User Navigation Equipment" NAVITEC 2004
3. N. Paragios and V. Ramesh "An MEF based approach for real-time Subway monitoring." In IEEE Conference on Computer Vision and Pattern Recognition, 2001
4. Polivka A, Filip "A. Satellite based positioning for CBTC. In: Proceedings of 2nd international conference on Reliability, safety and diagnostics of transport structures and means" Pardubice, 2005
5. Xu T, Tang T, Gao C, et al. "Dependability analysis of the data communication system in train control system" S E Tech Sci, 2009,52(9):
6. Fan L J. "Application of ERTMS/ETCS in train control system" Chin Rail Sci, 2003, 24(3): 98
7. Saab S. A "map matching approach for train positioning" part II: application and experimentation. IEEE T Veh Techno, 2000,49(2)
8. [www.google.com](http://www.google.com)
9. <https://m.indiamart.com>
10. [www.electrical4u.com](http://www.electrical4u.com)
11. [www.dgvcl.com](http://www.dgvcl.com)
12. [www.electricaltechnology.org](http://www.electricaltechnology.org)
13. Wikipedia