

IOT BASED HOME VISITOR MONITORING SYSTEM USING RASPBERRY PI

M.Vadivel¹, M.Poongodhai², R.Madhumitha³, V.Nivetha⁴, J.KamilaBanu⁵

¹Assistant Professor, Dept of ECE, V.S.B Engineering College, Tamil Nadu, India

^{2,3,4,5} B.E Student, Dept of ECE, V.S.B Engineering College, Tamil Nadu, India

Abstract - In today's world, face recognition is an important part for the purpose of security and surveillance. Hence there is a need for an efficient and cost effective system. Our goal is to explore the feasibility of implementing Raspberry Pi based face recognition system using conventional face detection. This paper aims at taking face recognition to a level in which the system can replace the use of passwords and RF I-Cards for access to high security systems and buildings. With the use of the Raspberry Pi kit, we aim at making the system cost effective and easy to use, with high performance. This paper details the design and development of IOT based security surveillance system in buildings using Raspberry Pi single board with Wi-Fi network connectivity. Upon detecting the face, the controller enables the camera for capturing the event, alerts the user by placing the live video of that event on webpage that is displayed in android mobile.

Key Words: Raspberry Pi, IOT, camera, Android app, SD card

1. INTRODUCTION

In the present situation, ensuring safety and security has become an inevitable essentiality. Since it is well known that influence of modern technology has reached its peak, demand for security systems are going up progressively. Modern home needs intelligent systems with minimum human effort. With the advent of digital and wireless technologies, automated security systems becomes more intelligent. Surveillance camera helps the user to get a remote view of his home. Surveillance is the monitoring of the location, behavior or activities for the purpose of directing, managing and detecting intrusion. IOT refers to system of interrelated computing devices and it plays a major role in surveillance. Android phone helps user to view the location from the remote area without human intervention.

1.1 Literature Survey

Among the existing surveillance techniques, CCTV is the most commonly used one. But it has its own limitations. It is a passive monitoring device and it needs continuous human intervention for monitoring. The investigation is a little bit hectic thing since all the previously recorded videos need to be watched manually. Moreover files can be corrupted very easily and this technique is costly too. These limitations lead to the development of active surveillance system. Several researchers have come up with the idea of active

surveillance systems in various papers. Most of the papers utilize the advantage of Wireless Sensor Networks (WSN) for surveillance. Since the sensor nodes being wireless, they can be placed any where inside the building, thus it achieves portability in deployment.

[1]. this paper describes the WSN based surveillance system monitored by Programmable System on Chip (PSOC) devices. Here Zigbee module is used for wireless transmission. The system mainly concentrates on sensor based alerts and it lacks improved techniques like camera, web server for uploading files etc.

[2]. This paper describes an improved real time home security system using BeagleBoard and Zigbee Remote alert on fire and intruder detection are the main features of the system. It uses improved techniques such as camera, GSM, FTP server etc. But it is not utilizing the advantage of live streaming and alerting techniques such as phone calls, SMS and email etc.

[3]. this paper describes the Internet of Things approach for motion detection using Raspberry Pi. It utilizes FTP server for camera feeds and it alerts user through email. The system does not have SMS and phone call alerts and other sensor alerts such as detection of fire, gas etc.

[4]. this paper explains a WSN based fire alarm system using Arduino. The system is purely based on sensor alerts and it lacks other features like camera, web server etc.

[5]. this paper describes the surveillance technique using IP camera and Arduino board. In this paper, user can view remote desktop using team viewer application whenever he needs to monitor his home from outside. This system is not sending any notification to user whenever any event occurs in his home. User has to monitor his home continuously and also it lacks sensor based alerts.

[6]. this paper describes the security surveillance system using raspberry pi. It utilizes the advantage of live streaming. But we need to type the IP address every time to watch the live video which is placed in webpage.

Most of the previous papers are utilizing Zigbee based WSN. But it has limited range and bandwidth. Some of the papers describe sensor alerts and it lacks the video surveillance, web servers, live streaming etc.

2. PROPOSED WORK

Smart surveillance system operated via android device by owner can be remotely as well as locally. IOT application for remote controlling is used, system will send the notification to android device, when an intrusion is detected at the door.

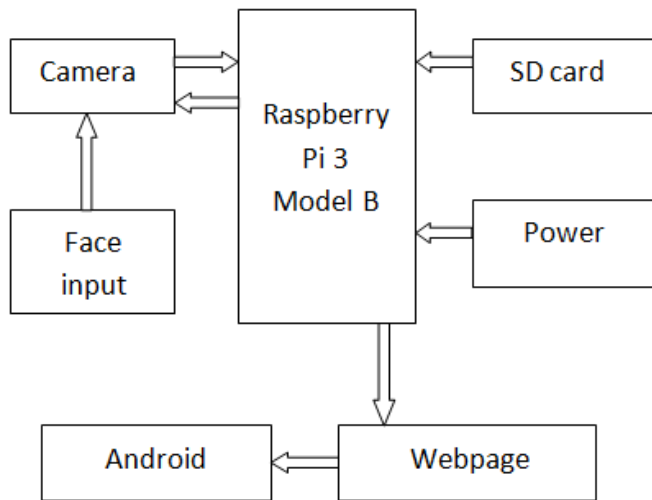

Fig-1: Block diagram of proposed work

It is required to develop and implement the affordable low cost surveillance system for remote security monitoring. Authorized user can access to their monitoring system remotely via internet with the use of mobile phone and monitor the situation on application. This entire work is done on raspberry pi with Raspbian as operating system. A Linux based Operating System (OS) called Raspbian OS is installed into SD card. RPi's desktop is accessed from laptop using ssh remote login. Then all the required libraries and software such as Open Source Computer Vision (Open CV), Python, streaming software (Motion), web server etc. were installed into it. We have used Open CV-python for writing application programs. Live streaming is done by executing the motion software.

When a person is detecting at the door, the camera will detect and capture the face of the person. The image is given to the Raspberry Pi through the USB port in the raspberry Pi. After receiving the image, that is given to the processor for further processing. Initially, the library files and the programs installed in the SD card. This SD card is paced in the SD card slot. The face recognition program will run while receiving that image.

For recognizing the face, Local Binary Pattern Histogram algorithm is used. That algorithm divides the image into blocks and divide each block into 3*3 window move it across one image. At each move (each local part of the picture), compare the pixel at the center, with its surrounding pixels. Denote the neighbors with intensity value less than or equal to the center pixel by 1 and the rest by 0. After you read these 0/1 values under the 3*3 window

in a clockwise order, you will have a binary pattern like 11100011 that is local to a particular area of the picture. When you finish doing this on the whole image, you will have a list of local binary patterns.

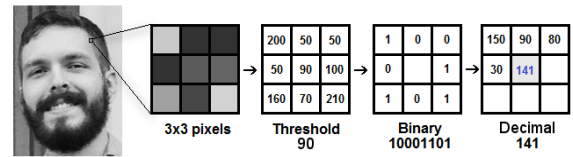

Fig -2: Creating local binary pattern for image

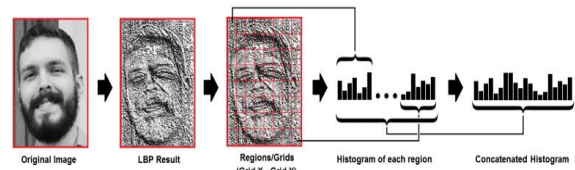

Fig-3: Extracting histogram from image

By using this value found in every block of an image, a histogram is drawn. The below figure shows the histogram extracted from an image.

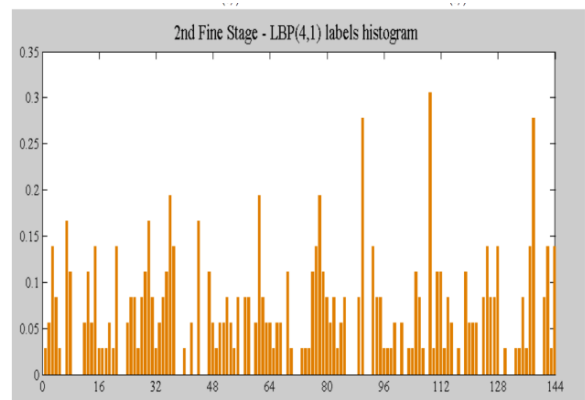

Fig -4: Extracted histogram from an image

This histogram is compared with the histogram generated and stored for a recognized persons in the data base. If it does not match with the histogram images in data base, the camera starts to record the video of the event for a particular time period. That time period will be specified in the program and the video will be captured.

The captured video is placed on the webpage that is created for the user by using the Real Time Streaming Protocol (RTSP). RTSP is responsible for transmitting the video to the webpage. It is the combination of both Real Time Transfer Protocol (RTP) and Real Time Control Protocol (RTCP). The RTP protocol is responsible for converting the video into RTP packets and transmitting them to webpage. RTCP does not involve in the transmission of RTP packets but it controls the operations.

The RTP protocol converts the captured video into RTP packets and sends the packets one by one to the webpage. The each packet consists of source address, destination address, packet length and video frame. Once the video placed at the webpage, the user will receive the notification of the event, which is placed on the webpage. Web page is a document that is suitable for www (World Wide Web) and web browsers. The web page is viewed on the android mobile with the help of web browsers such as Google chrome, Mozilla fire fox etc. To view the webpage in mobile phone, the web view application is used which is inbuilt in the android itself.

Web view can help if your application provides data to the user that always requires internet connection for retrieving the data. Usually the default web browser opens and loads the destination URL (Uniform Resource Locator). It is colloquially termed as web address. By using this web address the browser will check the corresponding web page is present in the web server or not. Finally the video in the web page is viewed in the android.

In order to watch live video from anywhere, we use Port Forwarding Technique. It is a technique where the internal IP address and Port of a device is mapped to the external IP address and Port. Here, the IP address and streaming Port of RPi is added in the Port mapping window of Wi-Fi router. Thus, the RPi's IP address and Port is mapped to router's IP address and Port. Live video can be watched from anywhere using Router's IP address and Port. Video will be saved in RPi for future reference

3. RESULT OF IMPLEMENTATION

This figure shows the surveillance controller system implemented using Raspberry Pi. Raspberry Pi is powered by 5V adapter. The desktop of Raspberry Pi is accessed remotely from putty software which is installed on laptop.

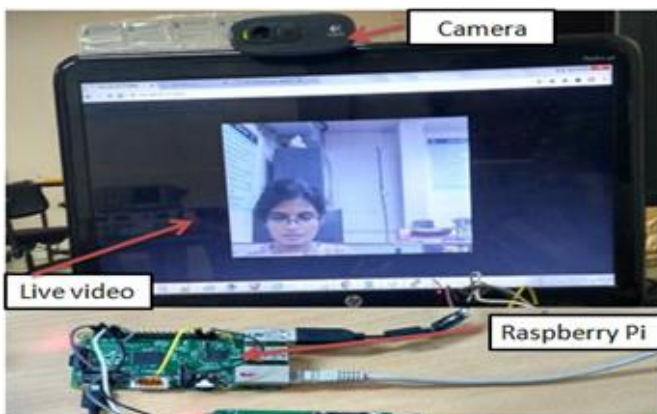

Fig-5: Surveillance controller system implemented using Raspberry Pi.

The screenshot of the live video is also shown in Fig. 8. User seeks surveillance on webpage using Wi-Fi router's

IP address. This system is useful for the owner to get a remote view of his home and to keep an eye on his valuables.

If the face is detected, it is recognized and then camera is activated, image is captured and sent to the user. After that, motion software is triggered, video is recorded and notification is send to user.

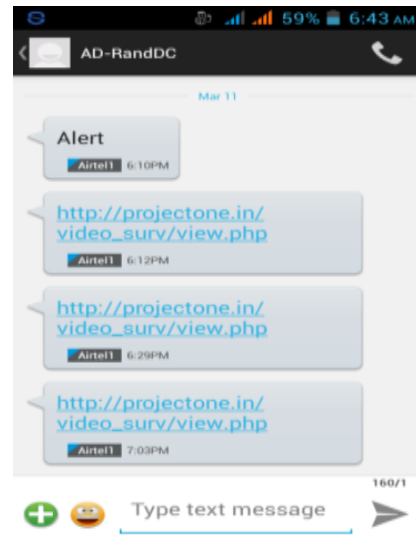

Fig-6: Shows the alert message with the webpage link in the mobile app.

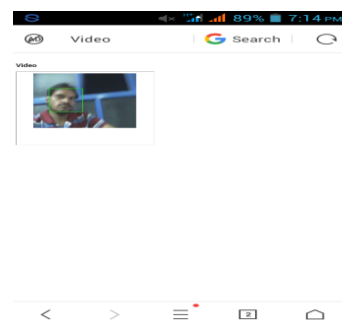

Fig-7: Screenshot of the live video displayed in android mobile.

4. CONCLUSION

In this paper, we have designed and developed a real time surveillance system using IOT module and Raspberry Pi. It is an active surveillance system which will alert the user when the event happens. Live video streaming is an additional advantage of this system. we have created web server which helps the user to view the live video. This system sends intruder's captured video to the owner by the android mobile. The IOT based smart surveillance system has been aimed to design in such a way that it can fulfil the needs of the user for particular surveillance area. It has countless applications and can be used in different environments and scenarios.

REFERENCES

- [1] Zhao, Yanbo, and Zhaohui Ye, "A low cost GSM/GPRS based wireless home security system", IEEE Transactions on Consumer Electronics 54, no. 2 (2008).
- [2] Rakesh, V. S., P. R. Sreesh, and Sudhish N. George, "An improved real-time surveillance system for home security system using BeagleBoard SBC, Zigbee and FTP webserver," IEEE Int.Con, 2012, pp. 1240-1244.
- [3] Ansari, Aamir Nizam, Mohamed Sedky, Neelam Sharma, and Anurag Tyagi, "An Internet of things approach for motion detection using Raspberry Pi," IEEE Int.Con. Intelligent Computing and Internet of Things, 2014, pp. 131-134.
- [4] Muheden, Karwan, Ebubekir Erdem, and Sercan Vanin, "Design and implementation of the mobile fire alarm system using wireless sensor networks," IEEE Int.Symp.Computational Intelligence and Informatcs, 2016, pp. 000243-000246.
- [5] Kumar, Sushant, and S. S. Solanki, "Remote home surveillance system," IEEE Int. Con. Advances in Computing, Communication, and Automation, 2016, pp. 1-4.
- [6] S. Sruthy, Sudhish N George "Wi-Fi enabled home security surveillance system using Raspberry Pi and IOT module".