

Continuous Authentication Using Wearable Medical Sensors

Syeda Afreen Mairaj¹, Indira Bahaddur²

¹Student, Dept. of E&C, MCE Hassan, Karnataka, India

²Assistant Professor, Dept. of E&C, MCE Hassan, Karnataka, India

Abstract – Most computer systems are protected through a process of user identification and authentication during initial login which can lead to security issues. Continuous authentication system is developed to resolve such issue. There are some previous methods for continuous authentication that uses biometrics i.e, face recognition or behaviometrics, e.g., key stroke patterns. Here, Continuous authentication system is developed using wireless wearable medical sensors. Continuous authentication using wearable sensors authenticates users based on the collection of biomedical signal streams that can be collected continuously and non-invasively using wearable medical devices like watches, belts etc, We collect data from different sensors continuously and based on those collected values authentication is provided. Then, we propose various applications and advantages and describe how it can be extended to user identification and adaptive access control authorization. Finally, the data collected from the sensors can further be used for health monitoring purposes.

Key Words: Authentication, wearable medical sensors, Continuous authentication.

1. INTRODUCTION

Authentication is the process of recognizing a user's identity. It is the mechanism of associating an incoming request with a set of identifying credentials. The credentials provided are compared to those on a file in a database of the authorized user's information on a local operating system or within an authentication server.

1.1 User Authentication

User authentication is one of the basic components of cyber security process. User is identified based on the password verification process to ensure that the user is authorized to access the resource, application and network. If the user enters the correct password then the user is allowed to access the application or systems.

But in some cases traditional authentication processes are not enough to provide strong security throughout a user work session. That's where continuous authentication comes in. The concept is still relatively new, and experts say few products yet exist in the market. But it's gaining more attention as companies look for ways to prevent unauthorized access to their critical business data.

1.2 Wearable Medical Sensors

Recently, wearable medical sensors (WMSs), which measure biomedical signals, e.g., heart rate, blood pressure, and body temperature, have drawn a lot of attention from researchers and begun to be adopted in practice[2][3]. A recent report by Business Insider [4] claims that 33 million wearable health monitoring devices were sold in 2015. It forecasts that this number will reach 148 million by 2019, and continue to grow rapidly thereafter. The use of continuously-collected biomedical data for user verification and identification seems promising for three reasons. First, if the biomedical signals are collected by WMSs for medical purposes, using them for authentication does not require any extra device that is not already on the body. Second, this information is collected transparently to the user, i.e., with minimal user involvement. Third, unlike traditional biometrics/behaviometrics, e.g., face features and keystroke patterns, information that may frequently become unavailable, the stream of biomedical signals collected by WMSs is always available when the person is wearing WMSs.

2. CONTINUOUS AUTHENTICATION

In this section we first briefly describe about the collection of signals from wearable medical sensors. Then we discuss about the working and implementation.

The different biomedical signals are collected continuously with the help of wearable medical devices and those signal values are continuously monitored and processed and then sent to the Smartphone. Wearable medical devices can be in the form of either wrist watches or belts that are not harmful to human body. Here, nine parameters/signals are considered due to variation in human body such as Blood Pressure, Heart Beat rate, Body Temperature etc. This helps in reducing the error as much as possible. Based on the processed values of the signals authorization is provided. Also, the collected data can be continuously monitored by the health monitoring person and provide information regarding the variation of the health of the user.

The Continuous health monitoring system consisting of different wearable medical sensors is as shown in figure 1.

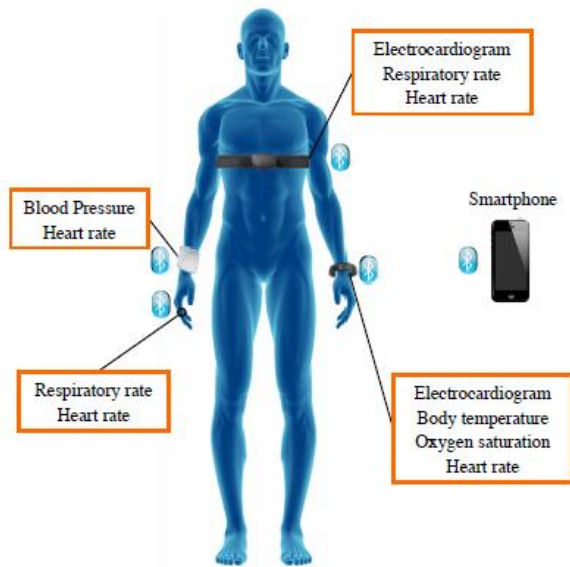

Fig-1:Continuous authentication using different wearable medical sensors

The implementation of continuous authentication using different wearable sensors can be performed as follows. The working block diagram of continuous authentication using wearable medical sensors is as shown in the figure 2.

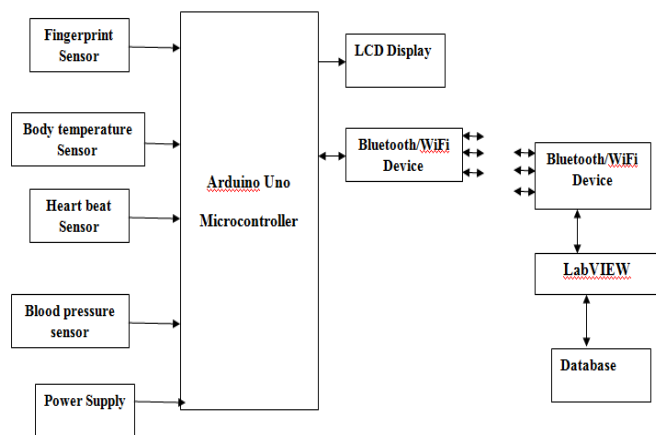

Fig -2: Working block diagram of continuous authentication using wearable medical sensors

In this above figure 2, wearable sensors are used to monitor body status continuously. Wearable sensors don't cause any harm to the body. So that anyone can wear the devices all the time. Authentication is nothing but verifying the person based on certain credentials. So to authenticate the person, this system is proposed which is based on bio aura. The sensors monitor the values continuously and send it to the LabVIEW through Bluetooth.

The process of verifying the person based on some activities or some monitored value is the authentication. And nowadays it is very important to know the body variations.

So this proposed system is going to develop in such a way that both the authentication and person's health monitoring application can be combined in single system so that no need of extra devices and one can save time. Traditionally authentication is carried out by using password or any other mechanism but these mechanisms are safety risk if the unauthorized persons can access the password and one can easily access the resources. So to overcome this, the proposed methodology is going to implement such that it uses finger printing sensor. Finger printing sensor continuously monitors the data and sends the data to the arduino. Then the monitored data can be sent to the LabVIEW through Bluetooth or wifi devices. Then the data can be stored and displayed on database which is created by using LabVIEW. So that database can store the values and can compare every time with the stored data. If it matches to previous one then it shows that the person is authorized one else unauthorized person.

The advantages of this system are as follows.

- 1)Continuous authentication
- 2)Leverages biomedical signals from wearable medical devices.
- 3)High accuracy
- 4)Can be integrated in personal devices or software products

The Applications of this systems are as follows.

- 1) Cyber security
- 2) Personal computing devices and servers
- 3) Software applications
- 4) Restricted areas
- 5) Health monitoring application

3. CONCLUSIONS

The Continuous authentication using wearable medical devices are used to authenticate the user continuously that is very much required now a days in companies.

This system combines both the applications of health monitoring and person authentication. So no need of extra devices and extra setup. It saves time and money therefore it is cost effective. And mainly it eliminated creation of webpage which is very complex. Instead of that LabVIEW database is used to store the data. LabVIEW is easy to learn and is cost effective.

REFERENCES

[1] Arsalan Mosenia and Susmita Sur-Kolay "Continuous Authentication Based on BioAura",IEEE paper

- [2] A. Pantelopoulos and N. G. Bourbakis, "A survey on wearable sensorbased systems for health monitoring and prognosis," *IEEE Trans. Systems, Man, and Cybernetics*, vol. 40, no. 1, pp. 1–12, 2010.
- [3] R. Gravina, P. Alinia, H. Ghasemzadeh, and G. Fortino, "Multi-sensor fusion in body sensor networks: State-of-the-art and research challenges," *Information Fusion*, vol. 35, pp. 68–80, 2017..
- [4] "Growth trends, consumer attitudes, and why smartwatches will dominate,"
"http://www.businessinsider.com/the-wearable-computing-marketreport- 2014-10, accessed: 08-1-2015.