

Power Stolen Prevention by Using PIC16882 Microcontroller

Shubhangi M. Raghute¹, Anurag K. Chakole², Shrikant R. Kharde³, Rahul G. Solanke⁴

^{1,2,3,4} Department of electrical engineering, W.C.E.M, Nagpur, Maharashtra, India.

Abstract – In developing countries, power theft is one of the most comprehensive issues which cause not only economic losses but also uneven supply of electricity. It frustrates working of industries and factories, due to shortage of power supplied to them. It causes shortage of power supply to homes. It leads to loss of income by Government as individual enterprises may option to install their own power generators, increases fraud in form of stimulus and many more. Science and technology with or its improvement has absorbed human life to a great increase that imagine a world without this invention is hardly possible, while technology is on their raising slope we should also note the increasing illegal activities. With technology view, “power stolen” is non ignorable crime that is highly extensive and at that time is directly affects the economy of nation. Data collected our Tirunelvile District; Bhel delicate proves the obligation of this project.

Key word: zero crossing detector, PIC16F886 micro-controller, regulator, driver, Tric etc.

1. INTRODUCTION

Our aim of project is to limit the power theft by banned tapping and meter fraud. Our project also implies the work as voltage stabilizer it feed a constant voltage to the load. Electric meter can be manipulated, thus causing them to stop, under register or bypassing the meter. Consumers, who are prevent with electric meter, quickly use power without paying for it. This theft or fraud can be threatening as well as false. A power regulator is a device which connects in series to power. Supposedly just by keeping the device connected it will instantly control and stabilize power usages at that instant. This system can claims savings between 20% and 30% electricity. It is known that the electricity that comes to our homes will not stable in nature. Our aim of project is to confine a power stolen by implementing a high voltage passing through the transmission line which will be allocated by a sub-station, by changing a taps of transformers anyway. Further this high voltage used by user through our system in which we regulate the voltage across the load up to a distinct limit. Those user who are operating their electrical devices through banned hooking or energy meter bypassing can be actually undergo by this high voltage, which may cause damages to the operating devices.

Above block diagram shows the operation of power stolen prevention by using PIC16Fmicrocontroller. The microcontroller controls the voltage across load through giving a firing angle to TRIAC. TRIAC is work as a switch and it operate when microcontroller gives the firing angle and firing angle pulse.

2. METHODOLOGY

In our project we are uses a power electronic device like TRIAC to control the power. Use of power electronic reduces the mechanical arcing and fast reaction time. In addition to this we also made a arrangement for under/ over voltage conservation which don't have any actual energy meters. Microcontroller evaluate the incoming voltage coming from line with the help of ADC (Analog to Digital Controller) present inside the microcontroller, is used to control a positive as well as negative half cycle of incoming AC for that a firing angle control method is used For controlling a firing angle of any AC voltage. It is necessary to monitor every positive / negative half cycle, hence a Sine Wave Cycle Monitoring (Zero Crossing Detector) is use in our project, which brief a controller about start point of every cycle. Once controller knows the voltage across the load and signals from sine wave cycle monitor, controller calculate the firing angle and gives firing angle and firing angle pulse to the AC to AC converter in which TRIAC is used to form static switch for operation, it can operated on high voltage and high frequency as compared to mechanical switches, such as relay. The output of AC to AC converter is further give to reactor which is nothing but a type of single core step-up transformer. (220v-280v transformer is used in our project), which gives a 220v output at 140v AC input. The output 220v is further used by different types of load. The voltage across load is measured by the PIC-microcontroller with the help of potential transformer (PT). Potential transformer is used to step down to voltage across the load to be measured and rectified to DC, because microcontroller can read a voltage up to 5v DC only. In or project we are using relay for tripping the input voltage in case of very high voltage and low voltage which is beyond controllable limit. The relay used for 12v and controller can give peak of 5v. Hence it is required to amplify the 5v-12v for used to driver circuit. The microcontroller is used to control the firing angle of TRIAC to give the angle of triggering.

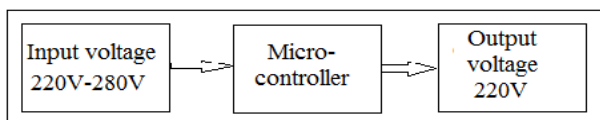

Fig-1: Block diagram of power stolen by controlling microcontroller.

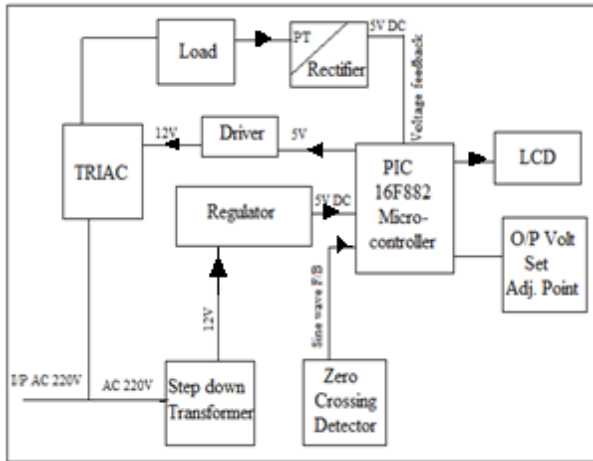

Fig-2: Block diagram of the proposed; system

The function of various blocks:

- Full Wave Rectifier (12VAC to 12VDC): A Full Wave Rectifier is a circuit, which converts an 12V AC voltage into a pulsating 12V DC voltage using both half cycles of the applied ac voltage. It uses two diodes of which one conducts during one half cycle while the other conducts during the other half cycle of the applied

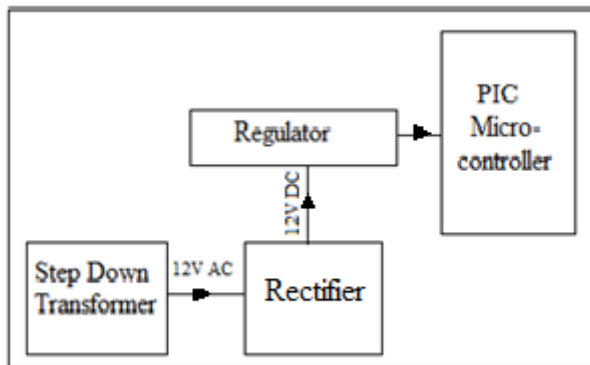

Fig-3: rectification in proposed system

- Voltage Regulator (12VDC to 5VDC): A voltage regulator is designed to frequently maintain a constant voltage level. It is used to stabilize the DC voltages used by the controller and other elements.
- A zero crossing detector: It is used to monitor a sine wave cycle. It is a one type of voltage comparator, used to distinguish a sine waveform transition from positive and negative that coincides when input crosses the zero voltage condition. In alternating current, the zero-crossing is the instantaneous point at which there is no voltage present. In a sine wave or other simple waveform, this normally happen twice during each cycle.

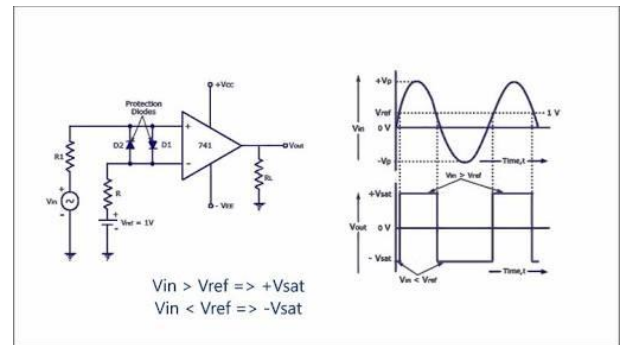

Fig-4: Zero Crossing Detector circuit

- Driver: A Microcontroller digital logic output pin supplies only 10mA of current to external devices such as high-power relays can require fewer than 100mA and they need more voltages. In order to control such devices which use high DC current, a transistor-based driver circuit is used to amplify current to the required levels. If the voltage and current levels are in moderate range, the transistor acts like a high-current switch controlled by the lower current digital logic signal.

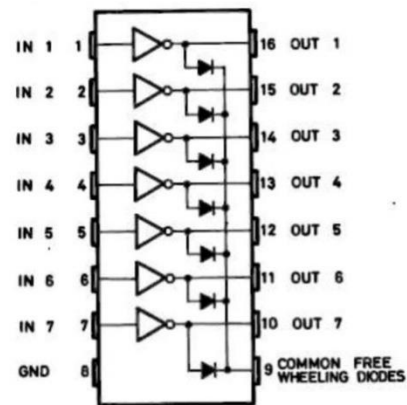

Fig-5: Diagram of driver

- Opto-coupler and driver: An opto-coupler are designed to provide complete electrical isolation between an input low voltage side (controller side) and output high voltage side (TRIAC side) circuits.

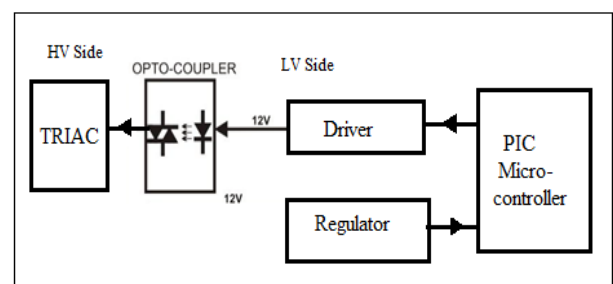

Fig-6: Opto-coupler circuit

- LCD: LCD (Liquid Crystal Display) screen is an electronic display module and used to display the operation of connected devices.
- TRIAC: These are Static devices used to switching operation. Static device is such device which converts one type of energy or energy level into another type of energy or energy level respectively without any physical movement.
- PIC Microcontroller: In our project we are using a PIC microcontroller which has RISC (restricted Instruction Set Codes) architecture due to which controller requires only One Clock Cycle to complete a single execution. In our project we are using a 28 pin microcontroller having 16K/b of FLASH ROM, 1.2K/b of RAM, and 256 bytes of EPROM.
- This controller having an inbuilt 10 Bit ADC which requires to measure input and output analog voltages. The operating cycle of PIC is of 200n/s. The output port efficiency is to deliver 5v/40mA on each port pins.

3. RESULT

The aim of our project is to prevent the power stealing, it control the power via monitoring through microcontroller. Our project will implementing when electricity supply authority passed the high voltage (220-280) for few minutes i.e, 2-3min, then power theft will be prevent by setting the firing angle of TRIAC by using microcontroller. In our project we give 220V-280V, after completing the operation, the output voltage feed variable between 210-240V across the load. The actual purpose of project is to be controlling high voltage and converted into required voltage.

Sr No	Input voltage	Output voltage
1.	280	238
2.	260	231
3.	240	210

Output tabale

4. CONCLUSION

Microcontroller based device which we design is easy to implement and beneficial for both energy supply authority and user. It also provide additional feature such as stabilize the voltage, it meal a constant voltage. It also gives the information of total load used in house on request at any time. The statistical load used and profile can help user manage their energy consumption. This system is secured and decent because it can access by automatic operation. This device has the efficiency to faced the high voltage and feed the constant voltage to household appliances. This

device help to reduced the stolen of power by implementing a high voltage through our system which stabilize the voltage, whose consumer used electricity by illegal hooking or bypassing the meter they will suffer by this high voltage. As this device stabilizes only higher voltage but by using active reactor in system, we can also maintain the output voltage if input voltage drop down to 160V. It will completely eliminate the power theft and will increase revenue for the government and save electricity.

REFERENCES

[1] Krunal Patel Electrical system, Centre of Excellence Raychem Innovation Centre, Raychem RPG Pvt. Ltd. Halol, Gujarat, India

[2] Muhammad Tariq is with the Electrical Engineering Department, Princeton University, NJ, USA, 08544. IEEE Transaction on smart grid (volume: PP, Issue: 99), 25 August 201

[3] J. Nagi, K. S. Yap, S.K. Tiong, S. K. Ahmed, Malik Mohomad, "Non Technical Loss Detection for Metered consumer using support vector machine", IEEE transaction on Power Delivery, Vol.25, April 2010

[4] Shailesh Sankpal / Omkar Kadam Electrical Engineering Department, Sanjeevan Engineering and Technology, Panhala, Maharashtra, IEEE, 07 May 2015

[5] Gruhesh Swaminatham ;Maheedar Subramanian ;Pravin Thangaraj "Distribution Line Monitoring Detection of Power Theft Using Power Line Communication", Energy Conversion (CENCON), 2014 IEEE Conference Date: 13-15 Oct 2014