

AUTOMATIVE IMPREGNABLE DRIVING SYSTEM

P.Prapthi¹, K,Raghavi², M.Sandhiya³

^{1,2,3} Student , Dept. of Information Technology, Valliammai Engineering College ,Chennai ,Tamil Nadu

Abstract - Cloud computing and Internet of Things (IoT) are two different technologies that are already a part of our life, their application and use is expected to be more and more pervasive that enables an ubiquitous access to the shared pool of resources and services. Internet of Things (IoT) is becoming increasingly important for Vehicle Monitoring, Medical Treatment, Home Automation and other industrial applications. The system proposed continuously monitors the status of the vehicle and overcomes issues like theft on the parking, driving insecurity and rise in death due to accidents. The safe of vehicles is extremely essential for public. Therefore, several research groups and major motorcycle manufacturers have developed safety devices to protect riders from accidental injuries. However, good safety device for vehicle is difficult to implement and very expensive. In this system, authentication of drivers is provided by means of RFID and Fingerprint sensor. Also for driver security, we have integrated IR sensor (seat belt) and Alcohol sensor (alcohol consumption). For each module, voice output would be triggered. Proposed system involves authentication of drivers & provide solutions to overcome the vehicle thefts. In fingerprint authentication, only the authorized person is passed and vehicle ignition will be initiated. For fingerprint feature extraction, we used Orientation Map algorithm. Keypad is been integrated to Enroll, Identify and Delete. If any other person rather than the authorized person is trying to access the vehicle, responsive GSM will be initiated and only the authorized person can give the permission rights. After this the vehicle ignition is switched ON / OFF. Finally, the sensor data and driver personal details like name and license number are transmitted to the IoT server. The result of the proposed system includes various parameters such as data type, speed of transmission, coverage of system, size of the coverage area and the number of vehicles to be closely monitored.

Key Words: IoT (Internet of Things), Cloud computing, RFID, Fingerprint sensor, IR sensor, Alcohol sensor, GSM, Orientation Map Algorithm.

INTRODUCTION

World population has increased enormously with some growth in technology. Nowadays more death is happening because of accidents. A system is proposed in order to detect an accident. Currently almost all the public own a vehicle. Theft is happening on parking and constraints driving securities. Vehicle accidents and thefts are the major issues faced by the public. Violating the safety precautions, traffic rules and regulations are the major causes. Though many acts have been developed for preventing the vehicle

accidents, many of us are not obeying it. safe of the vehicle is essential for the public. therefore several research group and major motor cycle manufacturers have developed safety devices to protect riders from accidental injuries. however good safety device for vehicle is difficult to implement and is often expensive.

In current scenario, vehicle security is provided by means of remote control access technology where a keyless entry system (RKS) is used. A keyless entry system is an electronic lock that control access to a vehicle without using traditional mechanical key. It is widely used in automobiles.

RKS (remote keyless system) performs the function of standard car key without physical contact. Within few yards the car can lock or unlock the doors by pressing a button. The major disadvantage of this technology is that the vehicle can be accessed by any person when the key is stolen.

In the existing system various sensors are operating independently whereas in our proposed system sensors are operated in a sequence. These sensor operations are implemented using embedded system. An Embedded system is a special purpose computer controlled electro-mechanical system in which the computer is completely encapsulated by the device it controls. An embedded system has specific requirements and performs pre-defined task unlike a general-purpose personal computer.

The core of any embedded system is a microprocessor which is programmed to perform a few tasks (often just one task). This is to be compared to other computer systems with general purpose hardware and externally loaded software. Embedded systems are often designed for mass production.

Apart from these sensor operations fingerprint authentication along with responsive GSM is used. This technique provides strong anti-spoofing capabilities when compared to other technologies. As fingerprints are internal to the body, it is difficult to duplicate. In responsive GSM authorized person can give access rights to others.

A low cost vehicle authentication system is designed to reduce loss of human lives and prevent thefts. Thus this system reduces the probability of a severe injury or an accident.

RELATED WORK:

In [1] K . A . Manum , Z . Ashraf (2015) "ANTI-THEFT VEHICLE SECURITY SYSTEM WITH PREVENTIVE ACTION" Computer Science and Engineering(APWC on CSE) Computer Science and Engineering (APWC on CSE), intelligent, reliable, effective and economical system for protection of vehicles is explained. The Anti- Theft Vehicle Security System (ATV2S) has been designed and implemented utilizing sensor - network system which employ Global Positioning System (GPS) and Global system for mobile communication (GSM) technology to track the vehicle. The cutting edge technology of ATV2S is capable of protecting , monitoring and tracking the vehicle within a minute. It is designed in such a way that it will automatically inform the owner of the vehicle if someone tries to access the vehicle. The owner receives the phone call and he can lock the engine of the vehicle by entering the predefined password to system. The engine will unlock if and only if another password from the owner is sent through mobile to the ATV2S. This self-monitoring system is affordable and cost effective for personal users not necessarily for vehicle but also for other security systems.

In [2] P. Jyothi , G. Harish (2016) "Design And Implementation Of Real Time Vehicle Monitoring, Tracking And Controlling System" International Conference on Communication and Electronic Systems (ICCES) , an advanced vehicle monitoring and tracking system that works on GPS / GSM module wherein the position is determined on the web page and monitored. The GPS is used to track the current location of the vehicle while the GSM is used to send the alert message to the owners mobile. If the driver drives the vehicle on the wrong path or if the speed goes beyond a specified value, an alert message will be sent from the system to the owner's mobile and speakers are driven for alert. The vehicle speed is controlled using PWM pulses. To protect the vehicle from over engine heat and gas leakages, two sensors are used namely, LM35 sensor and gas detection sensor. If any one of the sensor is being activated, authorized person is alerted along with the GPS values.

In [3] Longhua Guo , Mianxiong Dong , Kaoru Ota , Quina Li , Tianpeng Ye, Jun Wu and Jianhua Li (2017)" A Secure Mechanism for Big Data Collection in Large Scale Internet of Vehicle" IEEE Internet of Thing, a secure mechanism for big data collection in large scale Iov is proposed for improved security performance and efficiency. The vehicles need to register in order to connect into the network and exchange necessary information with the data center. These vehicles associate with the big data center via mutual authentication and single sign-on algorithm. Big data is collected by employing two different secure protocols and stored in distributed system using Hadoop architecture. In the initialization phase, authentication towards all new adding vehicle nodes forms the first security line of defense against illegal nodes. After the initialization phase, the proposed secure single sign-on algorithm improves the efficiency of the logon protocol. Besides, the collected information is transferred under protection until logout.

In [4] M.F. Saaid, M.A. Kamaludin, M.S.A. Megat Ali(2014) "Vehicle Location Finder Using Global Position System and Global System for Mobile" IEEE 5th Control and System Graduate Research Colloquium , a controllable system that can display the location of vehicle using Global position system (GPS) to pin point the location and Global System for Mobile (GSM) as a mean for communicating with the vehicle for ease of locating after a theft attempt. The system can be used as location detector and guarding tool against vehicle theft by combining a micro controller with GPS and GSM.

In [5] Mrinmoy Dey , Md. Akteruzzama Arif , Md. Asif Mahmud (2017) "Anti-theft Protection of Vehicle by GSM & GPS with Fingerprint Verification" International Conference on Electrical, Computer and Communication Engineering (ECCE) , single-board embedded system equipped with global system for mobile (GSM) and global positioning system (GPS) along with a microcontroller installed in the vehicle. The use of GSM and GPS technologies allows to track the vehicle and provides the up-to date information. GPS receiver receives messages from satellites and that is used to determine the satellite positions and time sent. Moreover, fingerprint sensor is used for biometric verification which ensures the driving of correct person. Optical sensor technology is used for this purpose. Captured finger image is digitally processed and stored in memory as a template. Fingerprint matching algorithm is used to compare the previously enrolled image for authentication. If vehicle's location is changed without fingerprint verification, the GPS engine will collect the co-ordinate of that place and send SMS to the owner of the vehicle. The implemented system is very simple with greater security against vehicle theft and is a low cost technique compared to others.

In [6] Liu , Anqi Zhang , Shaojun Li (2013) "Vehicle anti-theft tracking system based on Internet of things" , Vehicular Electronics and Safety (ICVES) ,IEEE International Conference , Anti-theft monitoring system based on GPS, GSM system and android application, controlled by an RFID module to switch ON / OFF . When the car is stolen, the vibration sensors and pyroelectric infrared sensors mounted inside the vehicle are triggered and GSM module will send the location information to the owners mobile phone. This system uses android mobile phones as terminal which is more convenient and flexible to locate and monitor the car in real time. Thus the owner can check and track the position of car immediately with android mobile phone application once the car is stolen .

PROPOSED SYSTEM:

For driver security, we have integrated IR sensor and Alcohol sensor. IR sensor is used for detection of seat belt. While alcohol sensor will return the alcohol concentration. The driver will be alerted once the concentration reaches beyond the threshold value. For each module, voice output would be triggered. If ignored, relay is being activated which will then stop down the car. To overcome vehicle thefts, proposed system involves authentication by means of RFID

and fingerprint sensor where only the authorized person is passed and vehicle ignition will be initiated. For fingerprint feature extraction, we used Orientation Map Algorithm (OM). Keypad is been integrated to Enroll, Identify and Delete the fingerprint images. If any other person other than the authorized person is trying to access the vehicle, responsive GSM will be initiated and only the authorized person can give the permission rights. The vehicle ignition is then switched ON / OFF. The driver authentication details like fingerprint and license numbers are stored on the local kit. For updating into IoT server we are using GSM module. For microcontroller we are using PIC microcontroller. These sensor data are being monitored on the website by the owner of the vehicle.

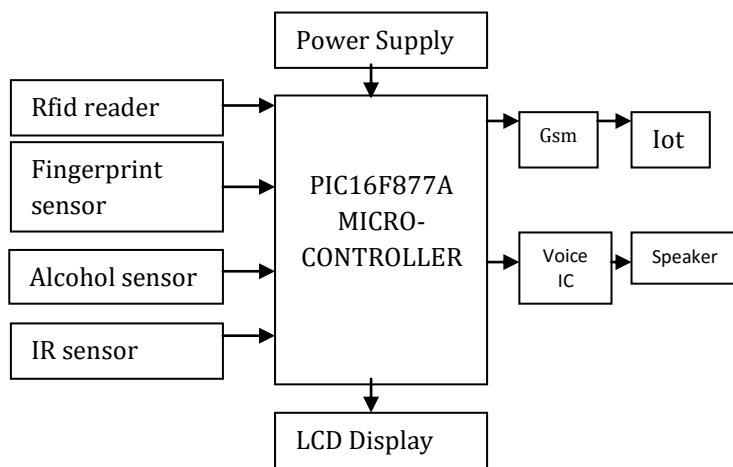

METHODOLOGY:

Orientation map technique represents the direction of the ridges. The fingerprint image is divided into number of non-overlapping blocks and an orientation representative of the ridges in the block is assigned to the block based on analysis of grayscale gradients in the block. The block size depends on the inter ridge distance.

Overall 95% of the fingerprint can be classified in five classes. The five classes are as follows, arch (A), tented arch (T), right loop (R), left loop (L) and whorl (W). The T and A classes may be combined into one single class resulting in four classes. The orientation algorithm provides pattern which are easy to identify the classes.

A core point is the turning point of an inner-most ridge and a delta point is a place where two ridges running side by side diverge. Orientation field, dominant ridge flow and singular points are useful features for classification. An orientation field contains information about the local dominant orientations of fingerprint ridges, from which features such as singular points and dominant ridge line flow can be derived. The dominant ridge flow is represented by a set of curves running parallel to the ridges lines but not necessarily coinciding with ridges and valleys. Singular points of the fingerprints, called core and delta, are marked as filled circles and triangles, respectively.

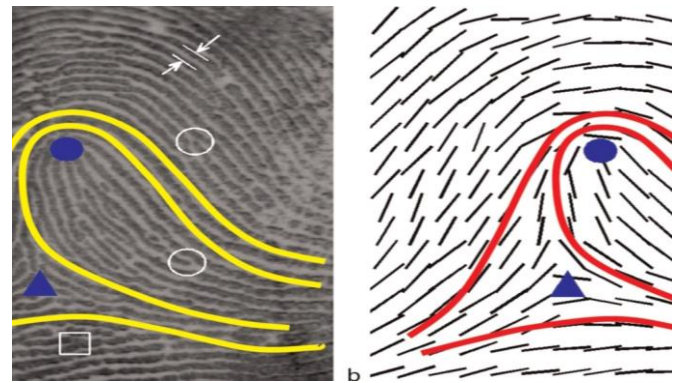

Three dominant ridge flow curves and the orientation field consisting of fingerprint local orientations is represented by short lines.

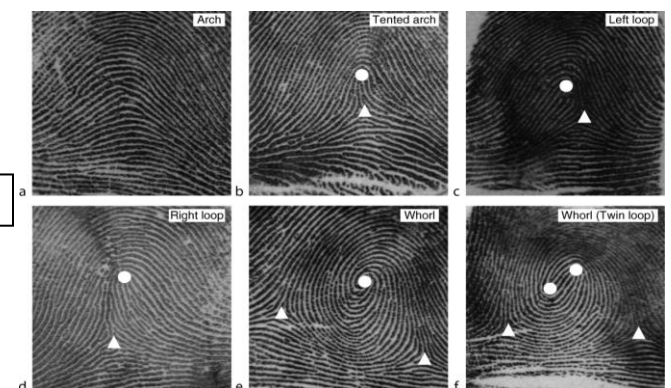

CONCLUSIONS

This system provides a novel safety function for predictive prevention of accidents and loss of vehicle. Measures such as alcohol consumption detection, seat belt detection and biometric authentication are being implemented. The sensors will collect data from the environment. If the data obtained reaches beyond the threshold value, the relay is being activated while simultaneously the voice o/p would be triggered. This accident avoidance framework ensures that it is mandatory for the user to wear a seat belt while driving and prohibits unauthorized access towards the vehicle.

FUTURE ENHANCEMENT

The reliable intelligent driver assistance system and safety warning system is a long way to go. New sensing technologies can be highly beneficial to the system environment. As computing power, sensing capacity and wireless connectivity for vehicles rapidly increases, the concept of assisted driving and proactive safety warning is heading towards reality. The system can be further extended to include different maneuvers to make the driving system capable of dealing with various driving environment. With current and growing awareness towards the importance of security, trustworthy vehicle autonomous system can be deployed.

Vision sensors and SAS's or drivers physiological signals such as ECG or PPG and the driving behavior of individual drivers can be monitored. This may require further research on analog signals processing techniques since physiological signals are weak and are vulnerable to noise and interferences. These technologies will further reduce accidents due to drivers incapacitation and enhance safety of automobile users.

REFERENCES

- [1] K . A . Manum , Z . Ashraf (2015) "Anti-theft vehicle security system with preventive action" Computer Science and Engineerig(APWC on CSE)
- [2] P.Jyothi ,G. Harish (2016) "Design And Implementation Of Real Time Vehicle Monitoring, Tracking And Controlling System" International Conference on Communication and Electronic Systems (ICCES)
- [3] Longhua Guo, Mianxiong Dong, Quina Li, Tianpeng Ye, Jun Wu and Jianhua Li (2017) " A Secure Mechanism for Big Data Collection in Large Scale Internet of Vehicles" IEEE Internet of Things Journal
- [4] M.F. Saaid, M.A. Kamaludin, M.S.A. Megat Ali(2014) "Vehicle Location Finder Using Global Position System and Global System for Mobile" IEEE 5th Control and System Graduate Research Colloquium
- [5] Mrinmoy Dey, Md. Akteruzzama Arif, Md. Asif Mahmud (2017) "Anti-theft Protection of Vehicle by GSM & GPS with Fingerprint Verification" International Conference on Electrical, Computer and Communication Engineering (ECCE)
- [6] Liu , Anqi Zhang , Shaojun Li (2013) "Vehicle anti-theft tracking system based on Internet of things" , Vehicular Electronics and Safety (ICVES), IEEE International Conference