

# Analysis and Design of Segmental Box Girder Bridge

MD TAUHEED REYAZ<sup>1</sup>, SYEDA NIKHAT FATHIMA<sup>2</sup>

<sup>1</sup>Lecturer, Dept of Civil Engineering, HMS Rural Polytechnic, Karnataka, India

<sup>2</sup>Assistant professor, Dept of Civil engineering, HMS Institute of technology Karnataka, India

\*\*\*

**Abstract** -A bridge may be a means that by that a road, railway or alternative service is carried over associate degree obstacle like a stream, depression and alternative road or railway line, either with no intermediate support or with solely a restricted range of supports at convenient locations. Strength, safety and economy area unit the 3 key options that can't be neglected before the culmination of sorts of bridges. Whereas deciding the kinds of bridge, spans and alternative parameters area unit to be studied fastidiously to fulfill the favorable conditions.

The design of a route bridge is critically smitten by standards and criteria. Naturally, the importance of route bridges in a very fashionable transit would imply a group of rigorous style specifications to confirm the protection, quality and overall price of the project. This work discusses the comparative analysis of 2 standards specifically AASHTO and IRC followed in construction of bridge superstructures subjected to load of serious vehicles for 2 sorts of examples specifically, beam with single cell and 4 cell and comparison has been given.. the look customary of Bharat, IRC was followed in style of Box girder superstructures subjected to IRC category AA loading In load combination, AASHTO codes have taken additional issue of safety than IRC. Analysis is disbursed victimization the Csi Bridge. The parameters thought-about to gift the responses of beam bridges specifically, longitudinal stresses at the highest and bottom, shear, torsion, moment, deflection and first harmonic of 2 sorts of beam bridges. Shear-z, torsion, moment-y impact on beam owing to IRC loading is additional as compared to AASHTO loading, i.e., vehicle load thought in IRC as compared to AASHTO It means that thought of impact think about AASHTO is additional compared to IRC.

## 1.INTRODUCTION

Bridges square measure outlined as structures that square measure provided a passage over a spot while not closing manner below. They will be required for a passage of railway, roadway, pathway and even for carriage of fluid, bridge web site ought to be therefore chosen that it offers most business and social edges, efficiency, effectiveness and equality. Connects square measure nation's life savers and spines inside the occasion of war. Spans symbolize goals and desires of mankind. They traverse boundaries that partition, bring people, groups and countries into nearer proximity. They abbreviate separations, speed transportation and encourage trade. Bridges square measure symbols of humanity's heroic struggle towards mastery of forces of nature and these square measure silent monuments of mankind's unconquerable can to achieve it. Bridge construction constitutes associate importance component in

communication and is a crucial consider progress of civilization, bridges stand as tributes to the work of civil engineers.

In order to supply safer and larger speed of traffic, the route is made as straight as potential Box girders, have gained wide acceptance in super highway and bridge systems owing to their structural potency, higher stability, unshakableness, economy of construction and pleasing ,aesthetics. In US Bridge Engineers utilize the code of AASHTO "American Association of route {expressway |freeway| motorway| pike| through way super highway| thruway| highway| main road} and Transportation Officials"; this code will be embraced for style of the expressway spans with unique needs. Thus, Indian extension engineers look for guidance from the IRC (Indian Road Congress) typical to attempt to the arranging but The AASHTO common place Specification is adopted by several countries because the typically accepted code for bridge styles.

Box girder bridges are terribly unremarkably used. It's a bridge that has its main beams comprising of girders within the form of hollow boxes. The create shaft usually incorporates of pre-focused on solid, steel or steel concrete. As appeared in Figure 1.1a create support crosses area could take the state of single cell (one box), different spines (separate boxes), or multi-cell with a standard base edge (nonstop cells) the container shaft span accomplishes its soundness in the fundamental because of 2 key components: structure and pre-focused on tendons.

Segmental box supports (sections) square measure utilized for building structure for scaffolds/diverse structure in substitution of standard development by means of pre-thrown bars and cast-in-situ decks. The portions framework decreases the ecological unsettling influence contrast with the customary method by consummation the cementing works more expelled from the advancement site wherever is normally settled at town focuses. Segmental box braces square measure basically designed as single traverse structures to abstain from coupling of post tensioning links. Further more in single traverses the bigger shear power isn't settled inside the same area in light of the fact that the best bowing minute, however' the joint between the sections is generally shut. A run of the mill range incorporates a length of approximately 45m. It comprises of twelve to fourteen sections according to the arranging. No ceaseless support is given over the match fashioned joints between the portions. A main advantage of the segmental bridge style is that it will builds additional simply construct bridges over areas wherever it's tough to move giant sections of concrete.

Segmental bridge construction is additionally reduces the essential thinking of style engineers.

For style of fundamental street and Railway Bridge superstructures there are a few codes utilized round the world and a large portion of the nations have their own particular code figuring on the characteristic conditions and in this way the nearby natural components, similar to the unsteady impacts, critical destruction, noteworthy snow, precipitous bundle, varying sorts of auto utilized in nation and so forth. Indian scaffold engineers elude IRC (Indian Road Congress) ordinary for the auxiliary style. amid this study 2 box-support cross-segments were planned with very surprising cross segment i) Pre focused on solid box bar with four cells, ii) Pre-focused on solid box pillar with single cell. The look parameters were unbroken same for each of the cross-sections.

Moving load as per IRC6: 2000 were thought off or each the cross wise and normal moving load IRC category AA was applied. Comparison was done between the results of each the box-girder cross-sections.

During this study 2 box-girder cross-sections were designed with totally different cross section- i) with four cells, ii) beam with single cell. The look parameters were unbroken same for each of the cross-sections. Moving load as per IRC-6: 2000 were thought of for each the crosswise and normal moving load IRC category AA was applied. Comparison was done between the results of each the box-girder cross sections.

### 1.1 OBJECTIVE

- To study the modelling and analysis pattern of Csi Bridge software
- To study the parametric behaviour of a prototype models i.e., single cell and four cell Box Girder Bridges.
- To compare the results for two types of loading namely AASHTO loading and IRC Class AA loading with respect to different prototype models considered.

## 2 PROBLEM FORMULATION

### 2.1 Problem Statement:

A box girder for 2 lane national highway bridge, with the data below:-

- Type of support:- simply supported
- length:- 30 m
- Carriageway width:- 7.5m
- foot path width:- 1.25m
- segmental width :- 10m

- load type :- IRC class AA loading
- concrete grade: M60 for both the cell types

### 2.2. FOUR CELLS PRE-STRESSED CONCRETE BOX GIRDER

#### 2.2.1. Material Properties and Allowable Stress:

#### 2.2.2 Tendon Properties:

Pre-stressing Strand:  $\phi 15.2$  mm (0.6"strand)  
 Yield Strength:  $f_{py} = 1.56906 \times 106 \text{ kN/m}^2$   
 Ultimate Strength:  $f_{pu} = 1.86326 \times 106 \text{ kN/m}^2$   
 Cross Sectional area of each tendon =  $0.0037449 \text{ m}^2$   
 Elastic modulus:  $E_{ps} = 2 \times 10^8 \text{ kN/m}^2$   
 Jacking Stress:  $f_{pj} = 0.7f_{pu} = 1330 \text{ N/mm}^2$   
 Curvature friction factor:  $\mu = 0.3 / \text{rad}$   
 Wobble friction factor:  $k = 0.0066 / \text{m}$   
 Slip of anchorage:  $s = 6 \text{ mm}$

#### 2.2.3. Cross Section Specifications

4 Cells Concrete Box-Girder with two traffic lanes  
 Vertical side walls

Top slab thickness = 300 mm  
 Bottom Slab thickness = 300 mm  
 External wall thickness = 300 mm  
 Internal Wall thickness = 300 mm  
 Span = 30m  
 Total width = 10m Road  
 Width of Carriage way = 7.5m  
 Wearing coat = 80mm  
 Cross-sectional Area =  $8.31 \text{ m}^2$

$I_{xx} = 1.304 \times 10 \text{ m}^4$   
 $I_{yy} = 4.591 \text{ m}^4$   
 $I_{zz} = 6.012 \times 10 \text{ m}^4$   
 Center:  $y = 5 \text{ m}$   
 Center:  $z = 1.0521 \text{ m}$

#### 2.2.4 Web Thickness: - (As per IRC: 18 - 2000):

The thickness of the online might not be but rather  $d/36$  and doubly the reasonable spread to the fortification and breadth of the pipe gap where,  $d$  is that the general profundity of the container pillar measured from the most astounding of the deck square to the least of the side or two hundred millimeter and the distance across of conduit gaps, whichever is bigger.

Web thickness = 300 mm > permissible value (safe)

#### 2.2.5 Bottom Flange thickness (As per IRC: 18 - 2000):

Bottom flange thickness might be at the very least  $1/20$  of the reasonable web dividing at the intersection with base rib or 200 mm whichever is more.

Bottom flange thickness = 300 mm > permissible value (safe)

**2.2.6 Top Flange thickness (As per IRC: 18 – 2000):**

The minimum thickness of the deck block as well as that cantilever tips be two hundred millimeter. For prime and base projection having pre-focusing on links, the thickness of such projection might not be but rather one hundred fifty millimeter and breadth of conduit opening. Top Flange thickness = 300 mm > permissible value (safe)

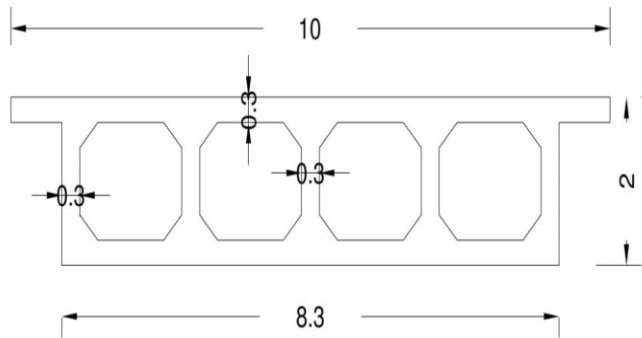

Figure 3.1 detail of cross section (units: meter)

**2.2.7 Loading on Box Girder:**

The different kind of masses, powers and burdens to be contemplated inside the investigation and style of the various parts of the extension are given in IRC 6:2000 (Section II) however the basic powers are pondered to style the model are as per the following: For IRC Class AA loading (IRC 6: 2000, Clause no 207.1, Page no. 10)

**2.2.8 Calculation of Ultimate Strength (As per IRC: 18-2000):**

i) Due to yield  
 $M_{ult} = 0.9dbAsFp$

ii) Due to crush  
 $M_{ult} = 0.176 b db^2fck$

**2.2.9 Ultimate Moment of Resistance (Analysis Result):**

➤ **Positive Moment:**

Internal B M,  $M_{Ed} = 40251.264kN.m$   
 Designed MOR,  $M_{Rd}$

$$M_{Rd} = F_{c,c}a_c + F_{s,s}a_s + \sum(F_{pi}a_{pi}) = 179131.251kN.m \quad (M_{Ed} \leq M_{Rd})$$

Structure is safe.

➤ **Negative Moment:**

Internal B M,  $M_{Ed} = 0.00kN.m$   
**(From analysis of the model)**  
 Designed MOR,  $M_{Rd}$

$$M_{Rd} = F_{c,c}a_c + F_{s,s}a_s + \sum(F_{pi}a_{pi}) = 253578.360 kN.m \quad (M_{Ed} \leq M_{Rd})$$

Structure is safe.

**2.2.10 Shear reinforcement (As per IRC 18: 2000 Clause 14.1.4):**

Whenever  $V > V_c$ , the shear power because of extreme burden is not exactly  $V_c/2$  then no shear support should be given. Least shear fortification might be given when  $V$  is more prominent than  $V_c/2$  as connections  $A_{sv}/s_v \times 0.87F_{yv}/b = 0.4MP$

If  $V > V_c$ , the shear reinforcement provided.

Internal SF,  $V_{Ed} = 948.194kN$

Designed SF,

$$VRd = (I \cdot bw / S) \cdot \sqrt{((f_{ctd})^2 + \alpha_l \cdot \sigma_{cp} \cdot f_{ctd})} \geq (v_{min} + k_1 \cdot \sigma_{cp}) \cdot bw \cdot dp$$

$$= 5841.628kN$$

$$V_{Ed} < VRd$$

Maximum BM @ mid section = 10631.1kN.m

Maximum Deflection at mid section = 17.06 mm

Total concrete quantity = 249.3 m<sup>3</sup>

Steel quantity = 26.272 MT

**2.3 SINGLE CELL PRE-STRESSED CONCRETE BOX GIRDER**

**2.3.1. Material Properties and Allowable Stress:**

**2.3.2 Tendon Properties:**

Pre-stressing Strand:  $\phi 15.2$  mm (0.6"strand)

Yield Strength:  $f_{py} = 1.56906 \times 10^6 kN/m^2$

Ultimate Strength:  $f_{pu} = 1.86326 \times 10^6 kN/m^2$

Cross Sectional area of each tendon = 0.0037449 m<sup>2</sup>

Elastic modulus:  $E_{ps} = 2 \times 10^8 kN/m^2$

Jacking Stress:  $f_{pj} = 0.7f_{pu} = 1330 N/mm^2$

Curvature friction factor:  $\mu = 0.3 / rad$

Wobble friction factor:  $k = 0.0066 / m$

Slip of anchorage:  $s = 6$  mm (At the Beginning and at the End)

**2.3.3. Cross Section Specification:**

Trapezoidal Shape

Top slab thickness (Tapered) = at the center 300 mm & at corner 200 mm

Bottom Slab thickness = 200 mm

External wall thickness = 300 mm

Span = 30m

Total width = 10m Road

Carriage way width = 7.5m

Wearing coat = 80mm

Cross-sectional Area = 4.620 m<sup>2</sup>

$I_{xx} = 5.199 \times 10^4 m^4$

$I_{yy} = 2.353 m^4$

$I_{zz} = 2.652 \times 10^4 m^4$

Center:  $y = 5$  m

Center:  $z = 1.355$  m

**2.3.4 Web thickness: - (As per IRC: 18 – 2000):**

Web thickness should not be but rather  $d/36$  and twofold the reasonable spread to the fortification and distance across of the conduit opening where 'd' is that the general profundity of the container pillar measured from the most elevated of the deck square to the least of the side or two hundred millimetre and the width of channel gaps, whichever is bigger.

Web thickness = 300 mm > permissible value (safe)

**2.3.5 Bottom Flange thickness (As per IRC: 18 – 2000):**

Base rib thickness might be at least 1/twentieth of the unmistakable web dividing at the intersection with base rib or 200 mm whichever is more. Bottom flange thickness = 300 mm > permissible value (safe)

**2.3.6 Top Flange thickness (As per IRC: 18 – 2000):**

Deck slab thickness and additionally that at cantilever tips two hundred millimeter. For high and base projection having pre-focusing on links, the thickness of such projection might not be but rather one hundred fifty millimeter and diameter of conduit opening.

Top Flange thickness = 300 mm > permissible value (safe)

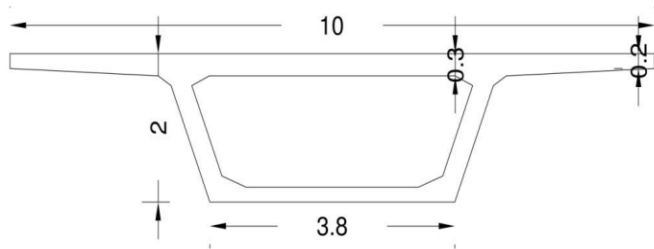

Figure 2.2 details of Single cell (units: meter)

**2.3.7 Loading on Box Girder:**

The different sorts of masses, powers and anxieties to be considered inside the examination and style of the fluctuated parts of the extension are given in IRC 6:2000 (Section II) however the basic strengths are considered to style the model are as per the following:

For IRC Class AA loading (IRC 6: 2000, Clause no 207.1, Page no. 10)

**2.3.8 Calculation of Ultimate Strength**

(As per IRC: 18-2000, Clause no. 13)

i) Due to yield

$$Mult = 0.9dbAsFp$$

ii) Due to crush

$$Mult = 0.176 b db 2fck$$

**2.3.9. Ultimate Moment of Resistance (Analysis Result):**

➤ **Positive Moment:**

internal BM,  $M_{Ed} = 14893.728kN.m$

Designed MOR,  $M_{Rd}$

$$M_{Rd} = F_{c,c}a_c + F_{s,s}a_s + \Sigma(F_{pi,a,pi}) = 85812.438kN.m \quad (M_{Ed} \leq M_{Rd})$$

Hence, Structure is safe.

➤ **Negative Moment:**

Internal BM,  $M_{Ed} = 0.00kN.m$

Designed MOR,  $M_{Rd}$

$$M_{Rd} = F_{c,c}a_c + F_{s,s}a_s + \Sigma(F_{pi,a,pi}) = 103656.221kN.m \quad (M_{Ed} \leq M_{Rd})$$

Hence, Structure is safe.

**2.3.10 Shear reinforcement (As per IRC 18: 2000 Clause 14.1.4):**

positions	P	V2	V3	T	M2	M3
At 12 mt span	KN	KN	KN	KN-m	KN-m	KN-m
Left exterior Girder	399.336	97.954	14.602	192.1264	42.9895	238.4307
Interior girder 1	466.355	211.258	15.762	438.3005	19.3051	590.82
Interior girder 2	556.239	288.256	10.258	102.5065	-2.099	837.5798
Interior girder 3	508.752	229.341	31.191	260.345	20.8122	555.6277
Right exterior Girder	452.483	160.271	17.427	119.6927	-53.816	178.9724
IRC- Class AA loading						
Left exterior Girder	583.611	395.511	-22.98	-770.15	27.8	1168.77
Interior girder 1	681.611	486.511	31.988	864.1455	38.5688	1068.8277
Interior girder 2	860.842	641.209	22.077	207.6559	-4.6872	1560.9097
Interior girder 3	773.797	631.092	54.997	-371.208	35.961	940.5436
Right exterior Girder	703.681	387.584	44.723	216.5541	92.0701	247.3959

Whenever  $V$ , the shear power because of extreme burden is not exactly  $V_c/2$  then no shear support should be given. Least shear fortification might be given when  $V$  is more noteworthy than  $V_c/2$  as connections

$$A_{sv}/S_v \times 0.87F_{yv}/b = 0.4MP$$

If  $V > V_c$ , the shear reinforcement provided.

InternalSF,  $V_{Ed} = 600.456kN$



Designed SF,

$$VRd = (I \cdot bw / S) \cdot \sqrt{((fctd)^2 + \alpha_1 \cdot \sigma_{cp} \cdot fctd)} \geq (v_{min} + k_1 \cdot \sigma_{cp}) \cdot bw \cdot dp$$

$$= 4668.975 \text{ kN}$$

$$VEd < VRd$$

Maximum BM @ mid section = 6276.96 kN.m

Maximum Deflection at mid section = 7.189 mm

Concrete quantity = 138.6 m<sup>3</sup>

Steel quantity = 18.167 MT

Strand quantity = 180.285 m

### 3. RESULTS & DISCUSSION

The four cells and single cell box beam bridge templates mentioned/formulated in chapter three area unit analyzed in CSI Bridge code and also the results area unit expressed intimately for 2 varieties of loading specifically, AASHTO loading pattern and IRC category AA loading.

#### 3.1 Four cell Box girder bridge-AASHTO and IRC loading

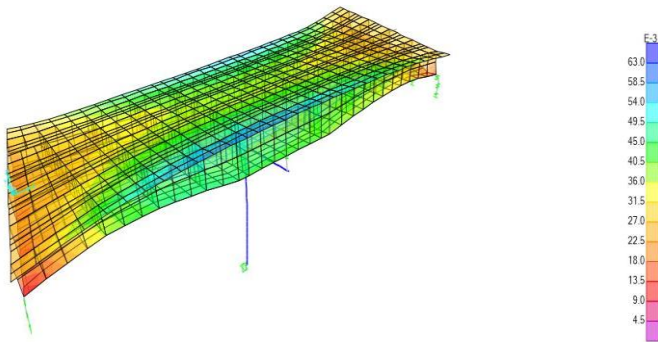
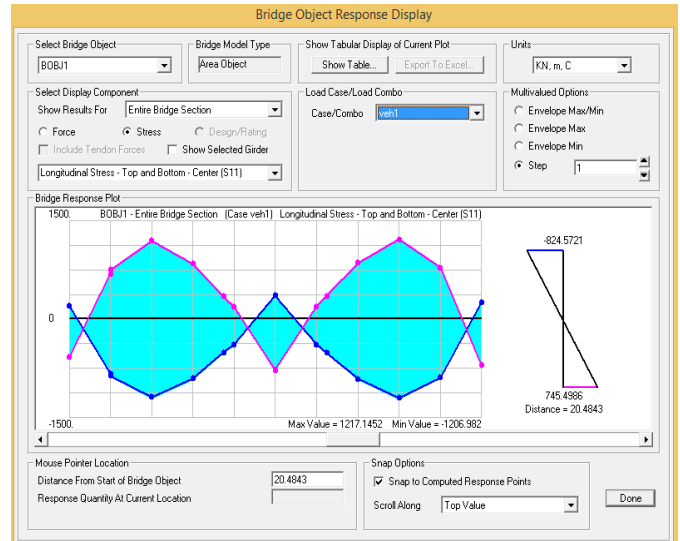

Figure 3.1 Deformed shape of four cell box girder bridge

Table 3.1 Analysis results for four Cell box girder at 12 mt section under AASHTO and IRC loading

At 12 mt	P	V2	V3	T	M2	M3
<b>Under AASHTO loading</b>						
m	KN	KN	KN	KN-m	KN-m	KN-m
Left exterior girder	-	206.033	64.277	54.0368	341.7238	3015.4561
Right exterior girder	451.587	365.239	85.134	835.8185	350.7367	2818.4975
<b>Under IRC class-AA loading</b>						
Left exterior girder Max	468.882	206.033	64.277	54.0368	341.7238	3015.4561
Min	468.882	206.033	64.277	54.0368	341.7238	3015.4561
Right exterior girder Max	451.587	365.239	85.134	835.8185	350.7367	2818.4975
Min	451.587	365.239	85.134	835.8185	350.7367	2818.4975



3.2 Bridge response display due to vehicular load(IRC Loading)

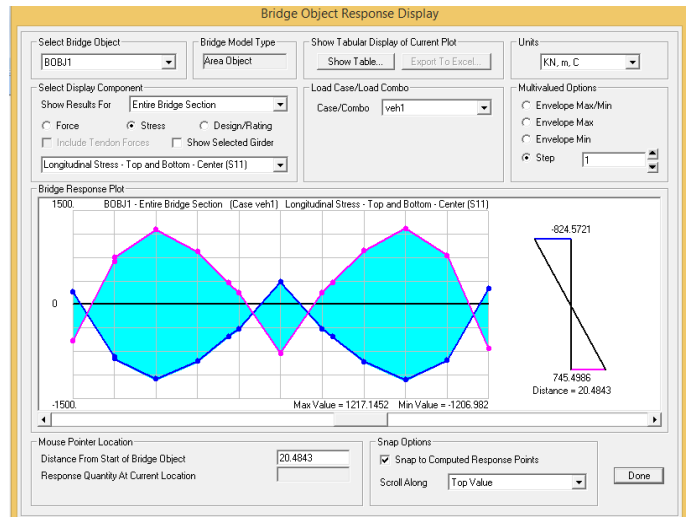

3.3 Bridge response display due to vehicular load(AASHTO Loading)

#### 3.2 Single cell Box girder bridge-AASHTO loading

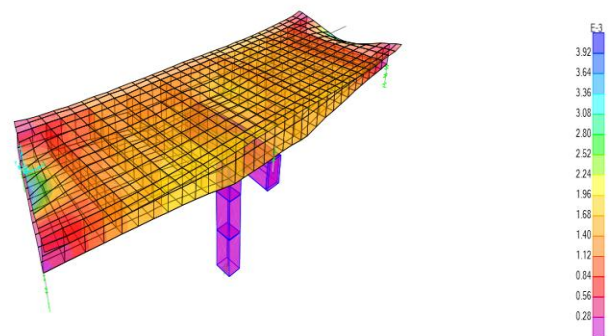

Figure 3.4 Deformed shape for single cell box girder bridge- AASHTO loading

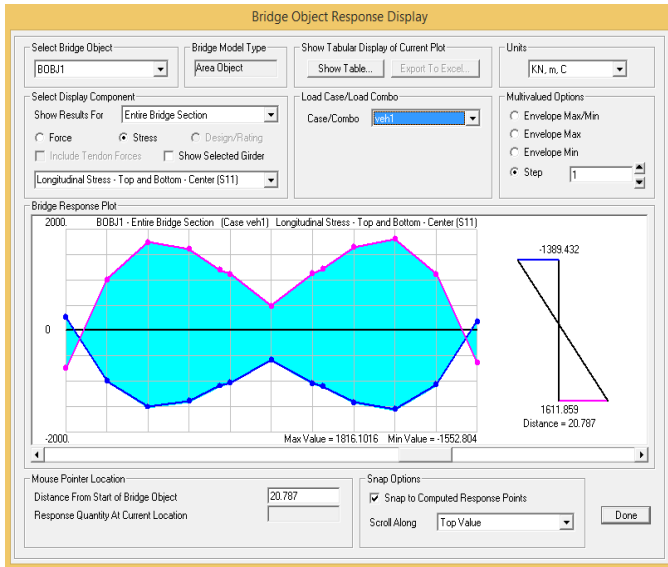

Figure 3.5 Bridge response display due to vehicular load

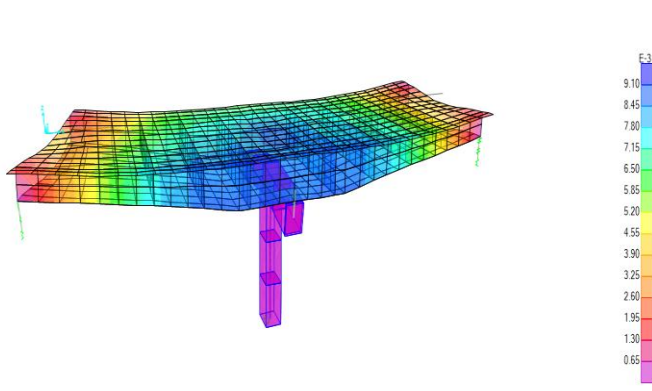

Figure 3.6 Deformed shape of single cell box girder bridge- IRC Class AA loading

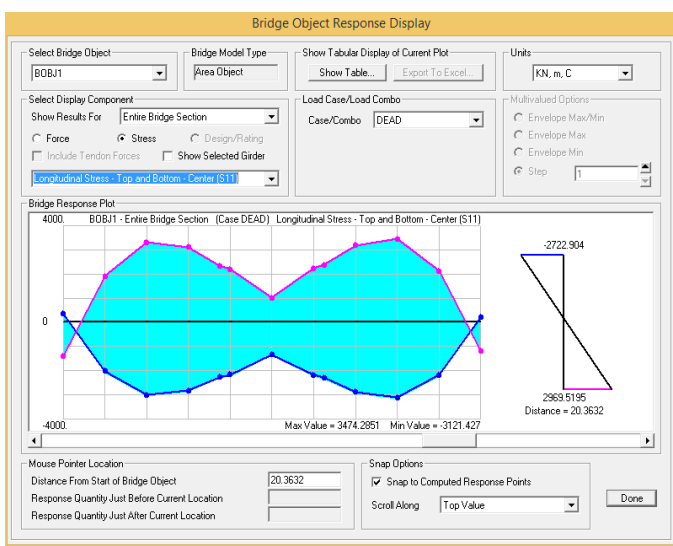
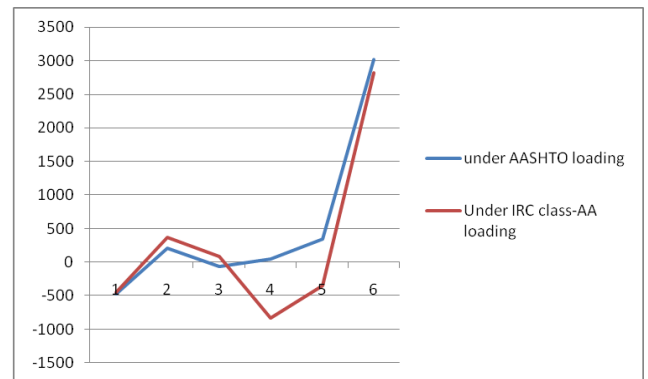

Figure 5.7 Bridge response display due to dead load

Table 5.1 Analysis results for single Cell box girder at 12 mt section under AASHTO and IRC Loading



### 3.6 comparison of AASHTO and IRC class-AA

- From the higher than table, twisting moment at completion bolster are zero, on account of simply backing condition, however inside the middle bolster it demonstrates the negative BM that is to be less contrast with positive BM.
- The higher than table shows the results of various forces in numerous girders for each IRC and AASHTO codes. The values of axial force in IRC show most at left ext. beam and right ext. girder. once compare to axial forces in IRC and AASHTO. The results of IRC axial forces ar high. equally once scrutiny the shear vertical and shear horizontal results ar additional in IRC codes and AASHTO code results ar less. Moment at vertical axis values is high in IRC code and extremely less in AASHTO code results. the instant at vertical axis values of interior girders ar terribly weak and high within the exterior girders for each codes. Moment at horizontal axis values is incredibly less in AASHTO code and high in IRC code results. the inside girders ar having the less values and exterior girders arhaving the high values in each the codes.
- In all forces IRC code results ar additional, as a result of in IRC the codes given for the Vehicle masses isadditional in comparison with AASHTO Codes. thus the pre-cast IGirder bridge is additional stable in IRC code in comparison with AASHTO code values.
- As we tend to onlooker the table qualities, Shear-z, torsion, moment y result on shaft on account of IRC stacking is extra when contrasted with AASHTO stacking, i.e., as an aftereffect of huge vehicle load thought in IRC when contrasted with AASHTO, however according to as effect variables worry, for AASHTO sway issue is 0.405 and for the IRC sway issue is 0.125, that are notice in higher than estimations. It suggests that thought of impact think about AASHTO is additional compared to IRC.

#### 4. CONCLUSIONS AND RECOMMENDATIONS

- The varied span to depth quantitative relation is taken for the analysis of beam bridges, and for all the cases, deflection and stresses are at intervals the permissible limits.
- As the depth of beam decreases, the prestressing force decreases and no. of cables decreases. Attributable to prestressing, additional strength of concrete is used and additionally well governs usefulness.
- A comparative study between four cell and single cell pre-stressed concrete beam Cross sections has been done. This study shows that the single cell pre-stressed concrete beam is most fitted and economical crosswise for two lane Indian national road bridges.
- It is found that the deflection obtained thanks to varied loading conditions and at service condition is well at intervals permissible limits as per IRC. the utmost vertical deflection is found to occur close to mid-span location of the beam.
- For the optimisation of section, different kinds of check out to be performed; those are applied during this paper. Results of bending moment and stress for self weight and superimposed weight are same, however those are totally different for the moving load thought, as a result of IRC codes offers style for the significant loading compared to the AASHTO codes. In load combination, AASHTO codes have taken additional issue of safety than IRC. space of prestressing steel needed for AASHTO is smaller amount compared to IRC.
- Finally supported this comparative study it's clear that AASHTO code is additional economical than IRC.

#### Future scope

1. The same study can be performed by considering other girder types namely Double Cell Box Girder and Triple Cell Box Girder bridges of different radius of curvature, span, length and span length to the radius of curvature ratio.
2. With late progression in material innovation, more study can be focussed on material qualities utilized i.e, different composite sections and joint configurations can be made use of to assess the variation in stresses at different locations
3. A further study can be made where an examination of a working with different irregularities like positioning of piers and comparison can also be

given for different bridge types namely, i bridge girder and box girders and simple supported girders and cantilever one.

#### REFERENCES

- 1) Angel Lopez and Angel C.Aparicio, "Nonlinear behaviour of curved prestressed box girder bridges", IABSE PERIODICA 1/1989 Univ. Politecnica de Catalunya, Barcelona, Spain, 2015, pp. 13-28.
- 2) Mayank Chourasia and Dr. Saleem Akhtar, "Design and Analysis of Prestressed Concrete Box Girder by Finite Element Method", International Journal of Civil and Structural Engineering Research ISSN 2348-7607 (Online) Vol. 3, Issue 1, pp: (413-421), April 2015 - September 2015
- 3) Muthanna Abbu, "3D FE modelling of composite box Girder Bridges", 2nd International Balkans Conference on Challenges of Civil Engineering, BCCCE, 23-25 May 2013, Epoka University, Tirana, Albania
- 4) P. V. Ramana, "FSM Analysis for Box Girder Bridges", International Journal of Advanced Electrical and Electronics Engineering (IJAE), ISSN (Print) : 2278-8948, Volume-2, Issue-6, 2013
- 5) Patil Yashavant and Prof. Shinde Sangita, "Comparative analysis of Box Girder Bridge with two different codes", (IJCIET), ISSN 0976 - 6308(Print), ISSN 0976 - 6316(Online) Volume 4, Issue 3, May June (2013)
- 6) Kenneth W. Shushkewich (July-1998), Approximate Analysis of Concrete Box Girder Bridges, ASCE, Journal of Bridge Engineering, Vol.114, No.7, Pg. 1644-1657
- 7) Khaled M. Sennah, John B. Kennedy ( march-2002 ), Literature Review in Analysis of Box Girder Bridges, ASCE, Journal of Bridge Engineering, Vol 7, No.2, Pg 134-143
- 8) W. Y. Li, L. G. Tham, Y. K. Cheung, (June1998), Curved Box Girder Bridges, ASCE, Journal of Bridge Engineering, Vol.114, No.7, Pg.1324-1338
- 9) Ricardo Gaspar, Fernando Reboucas Stucchi, (September-2013), Web Design of Box Girder Concrete Bridges, Engineering Structures 57, Pg. 267-275
- 10) Ayman M. Okeil, Sherif El Tawil, (September-2004), Warping Stresses in Curved Box Girder Bridges: Case study, ASCE, Journal of Bridge Engineering, Vol.9, No.5, Pg.487-496

- 11) Babu Kurian, Devdas Menon, (July-2007), Estimation of Collapse Load of Single-cell Concrete Box-Girder Bridges, ASCE, Journal of Bridge Engineering, Vol.12, No.4, Pg. 518- 526
- 12) Shi-Jun Zhou, (December-2011), Shear Lag Analysis in Prestressed Concrete Box Girders, ASCE, Journal of Bridge Engineering, Vol.16, No.4, Pg. 500-512  
159-167
- 13) Robert K. Dowell, Timothy P. Johnson, (September-2011), Closed-form Shear flow Solution for Box Girder Bridges under Torsion, Engineering Structures 34, Pg. 383-390
- 14) Imad Eldin Khalafalla, Khaled M. Sennah, (July-2014), Curvature Limitations for Slab-on-I-Girder Bridges, ASCE, Journal of Bridge Engineering, 04014031 Pg.1-14
- 15) Dereck J. Hodson, Paul J. Barr, Marvin W. Halling, (July-2012), live Load Analysis of Post tensioned Box-Girder Bridges, ASCE, Journal of Bridge Engineering, Vol.17, No.4, Pg. 664- 651