

# IMPROVEMENT OF POWER SYSTEM STABILITY IN WIND TURBINE BY USING FACTS DEVICES

P.Vijayalakshmi<sup>1</sup>, Dr.K.Balamurugan<sup>2</sup>

<sup>1</sup>PG scholar, Dept of Electrical and Electronics Engineering, Dr. MCET, Tamilnadu, India

<sup>2</sup>Associate Professor, Dept of Electrical and Electronics Engineering, Dr. MCET, Tamilnadu, India

\*\*\*

**Abstract** - This paper is to establish a predictive power control strategy which is used to improve the stability of power systems. This has been done in the presence of wind farms based on Doubly Fed Induction Generator [DFIG] using Static Synchronous Series Compensator [SSSC] and Super Capacitor Energy Storage System [SCESS]. In our proposed system, SCESS is used to control the active power in the Grid Side Converter [GSC] and SSSC is used to reduce the low frequency oscillations. SCESS is composed of a capacitor bank and a dual switch DC/DC converter which is connected to DFIG through the DC link. In this method, it is used to control the active and reactive power of the Rotor Side Converter [RSC] as well as damping controller design for SCESS and SSSC. For improving the power system stability, an SSSC is used, which is a modern power quality FACTS device that employs a voltage source converter connected in series to a transmission line through a transformer. The Model Predictive Control (MPC) is used, which will predict the future value of the system in order to increase the damping ratio of the system. Thus, the system has been simulated and tested on MATLAB/SIMULINK.

**Key Words:** Power system stability, predictive control, wind turbine, Doubly Fed Induction Generator (DFIG), Super Capacitor Energy Storage System (SCESS), Static Synchronous Series Compensator (SSSC), Model Predictive Control (MPC).

## 1. INTRODUCTION

Energy is a key to human development, and renewable energy can ensure energy needs are met while protecting local environments and populations. Even other sources of energy are finite and will someday be depleted. Now a day's renewable energy is the major source for the power generation. Among renewable resources, wind energy and solar energy is emerging technology. In that wind energy is the common energy to produce electrical signals all around the world. Due to oscillating behaviour of wind power, there will be some oscillations in electrical grids while transmitting the electrical signals. In a power system, these fluctuations from stable system and considering the power quality, it is a serious issue in power system [1&2]. For this, it is using a Super Capacitor Energy Storage System (SCESS) and Flexible AC Transmission System (FACTS) devices, which is used as a balancer to diminish oscillations and enhance damping in power system [3&4]. To eradicate this fluctuations and to improve damping, it has been done more number of studies in the field of power system. In those studies there will be some pros and cons in it. The

main objective of this paper is to increase the stability of the power system with the help of predictive control strategy. Because of the cost effectiveness and direct power control, Doubly Fed Induction Generator [DFIG] is taken as a common type of variable speed wind turbine [5]. Here, rotor of DFIG is coupled to the grid along with the back-to-back bi-directional converter and stator is coupled to grid. More number of studies has been done for the DFIG based control systems to improve stability such as Sensitivity Analysis and Hybrid Wavelet-PSO-ANFIS[6], Eigen value sensitivity analysis[7], state feedback[8]. It have been analysed the PI controllers, neural networks and fuzzy logic types but it also having some complexity and cons in it [9&10]. Now days, Super Capacitor Energy Storage System plays a vital role in reducing the fluctuations of DFIG power system [11&12]. For compensating the reactive power, Fly-Wheel Energy Storage System (FESS) [13&14] and Superconducting Magnetic Energy Storage (SMES) [15-17]. For reducing the low frequency oscillations in power system, we can use the FACTS devices. SSSC is an advanced type of FACTS devices in which it is connected in series along transmission lines [18&19]. There are various methods have been developed for designing a controller of SSSC [20-25]. Advanced control method known as model predictive control (MPC) is mostly used in industries and in research [26]. Here, in our proposed system, it will be having a wind turbine attached with the DFIG system. In this system, rectifier and inverter is used along with the Rotor Side Converter and Grid Side Converter respectively, which will acts as a pulse generator. Model Predictive Control (MPC) was designed and given as an input to SSSC. To reduce the oscillations, Super Capacitor Energy Storage System (SCESS) was designed and implemented.

## 2. DESIGN OF POWER SYSTEM ELEMENTS

### 2.1 Doubly Fed Induction Generator Type

In DFIG based wind turbine system, the grid side converter and rotor side converter are connected as back-to-back converter through DC link as shown in Fig-1. To maintain the balance between grid side converter and rotor side converter, DC link is used.

### 2.2 Design of Rotor Side Converter

Rotor Side Converter is used to extract the maximum power from wind, to control the active and reactive power of DFIG and it gives a reactive power needed

by the induction generator. In this controller, active power and voltage are regulated by  $U_{qr}$  and  $U_{dr}$  respectively. As shown in Fig-2, using the reactive power control, the voltage control is made by measuring  $X_{sw}$  and by measuring the turbine speed  $T_{rw}$ , the reactive power control is made. These control signals are compared along with the reference signals by PI controller for all the parameters; the reference signals ( $I_{qr\_ref}$ ,  $I_{dr\_ref}$ ) are measured. For producing the error signal, current reference signal is compared to the reference signals which are in d-q axis. These reference signals are amplified by current signals to produce  $U_{qr}$  and  $U_{dr}$  signal and it is send to Pulse Width Modulation. A signal from PWM is send to inverter to act as switching mode [7].

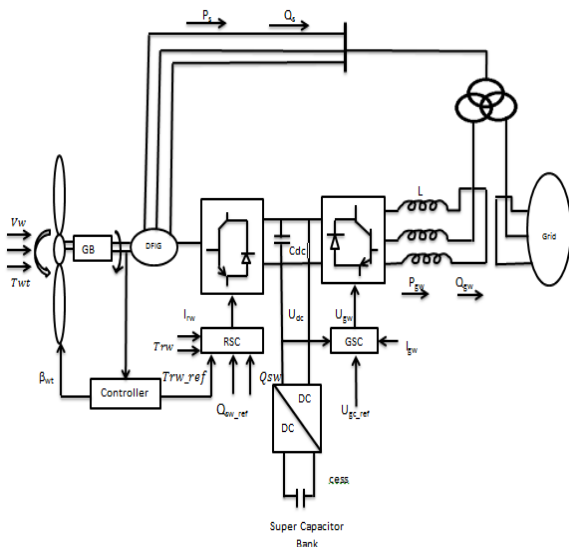

Fig-1: Block diagram of DFIG-based wind turbine model

### 2.3 Design of Grid Side Converter

Grid Side Converter is used to keep the constant DC voltage link and for controlling the reactive power of the system. Fig-3, explains the operations of Grid Side Converter in the system. In this paper, reference signal of DC link ( $U_{dc\_ref}$ ) is compared with the  $U_{dc}$  by PI controller. The current reference signals ( $I_{qg\_ref}$ ,  $I_{dg\_ref}$ ) is compared along with measured value. After combining the current signals,  $U_{dg}$ ,  $U_{qg}$  are produced and these signals are send to Pulse Width Modulation. The pulse from PWM is send to inverter to act as switching mode [7].

### 2.4 Design of SCESS converter

Super Capacitor Energy Storage System is used to control the DC link voltage. In this paper, damping controller is designed, which is used to control the reactive power of the system. SCESS converter consists of capacitor bank and dual switch DC/DC converter. This is connected to DFIG through DC link as in Fig-4. The switches  $S_1$  and  $S_2$  is used as boost and buck modes in the system. The converter will works as boost mode, when  $S_1$  opens. The converter will works as buck mode, when  $S_2$  opens.

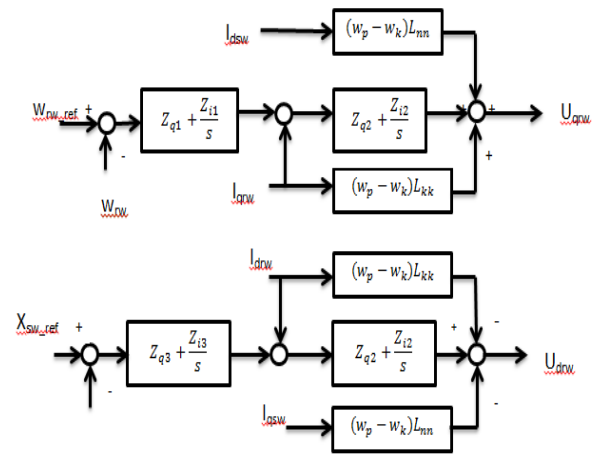

Fig-2: Block diagram of Rotor Side Converter

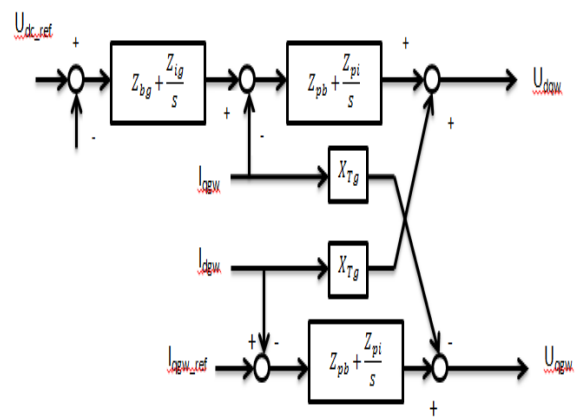

Fig-3: Block diagram of Grid Side Converter

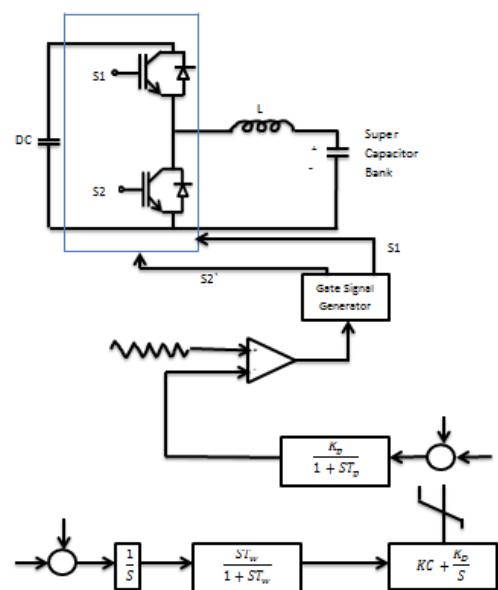

Fig-4: Design of damping controller of SCESS

### 2.5 Design of Static Synchronous Series Compensator

SSSC is a type of FACTS devices which is connected in series with transmission line. Depending upon voltage source inverter, SSSC is used as a reactive power compensator. SSSC can operate in capacitive and inductive modes. SSSC consists of voltage source inverter, series transformer, capacitor and control block as explained in Fig-5.

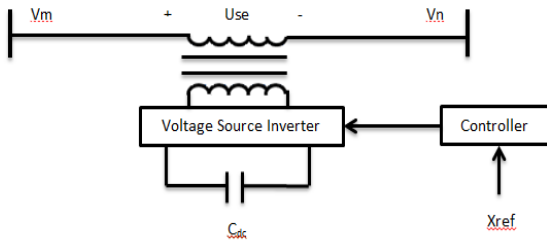

Fig-5: Circuit diagram of SSSC

The diagram of SSSC needed for capacitive mode of operation along with damping controller was given in Fig-6. By controlling the power in line, we can reduce the low frequency oscillations by adding the control signal in it.

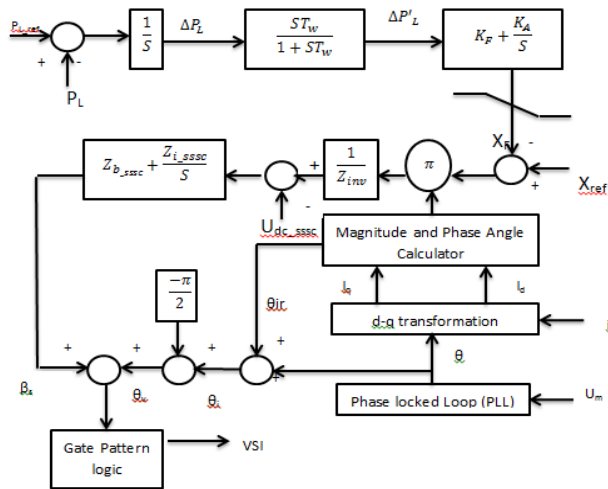

Fig-6: Design of damping controller of SSSC

### 3. CONTROLLER SECTION

For determining the future response of the system, a new powerful technique known as model predictive control was used in the system [27, 28]. For each problem, optimal point can be determined by using this method. For state estimation of the process, we can predict the input and output of the system. By using this control strategy, for each sampling interval, an optimization problem is solved in it. The changes can be made in the system as an error signal. In this method, predictive horizon is measured in the system for future response as described in Fig-7.

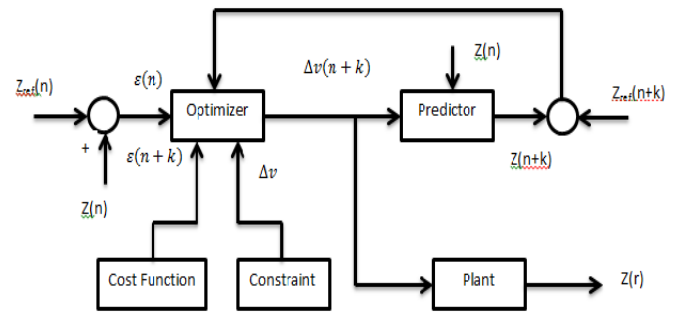

Fig-7: Structure of Model Predictive Control

### 4. SIMULATION RESULTS AND DISCUSSION

Simulation result of the DFIG design is given to the Rectifier based on Model Predictive Control (MPC) as shown in Fig-8. In this simulation results, it takes a 0.25s to get stable in voltage signal and 0.29s to get stable in current. After 0.25s and 0.29s, it will be having a voltage of 0.9V and current of 1A respectively. This is an output signal from DFIG which is given as an input to rectifier. By using a conventional PI controller, the oscillation time will nearly be 1s and it takes more time to stable compared to Model Predictive Control method.

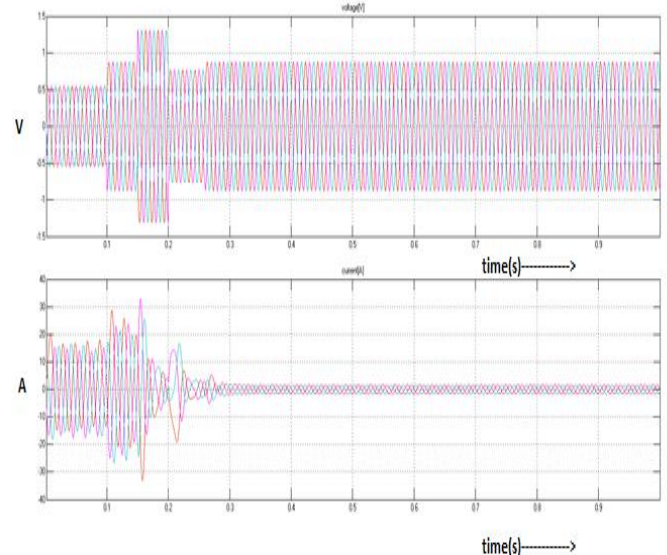

Fig-8: Input Signal of rectifier

Simulation results of inverter based on MPC are shown in Fig-9. In this simulation result, it takes a 0.25s to get stable in voltage signal and current. After 0.25s, it will be having a voltage of 0.015V and current of 0.7mA. After the energy storage system, the inverter gets the input and produces the output signal in it.

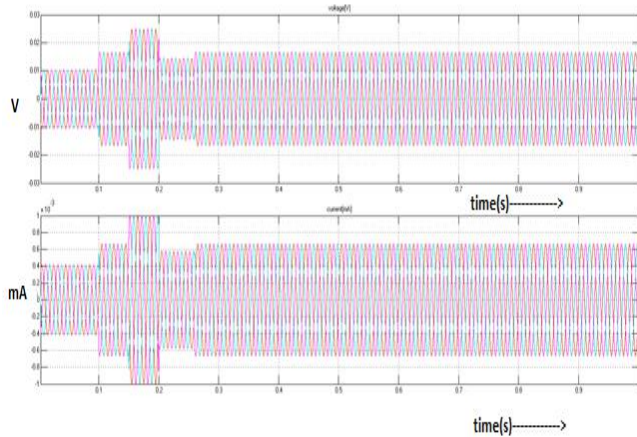

Fig-9: Signal from inverter

DFIG based wind turbine system was designed and the output signals are produced as shown in Fig-10. This system was designed based on Model Predictive Control (MPC). Here, it takes a 0.25s to get stable in voltage and 0.3s to get stable in current. After the signal gets stable, the voltage will be of 0.7mv and the current will be of 5mA in it. Whenever there is a changes in load, output signals will also changes in the system. To minimize the fluctuations, Model Predictive Control, SSSC and SCESS is used in the system.

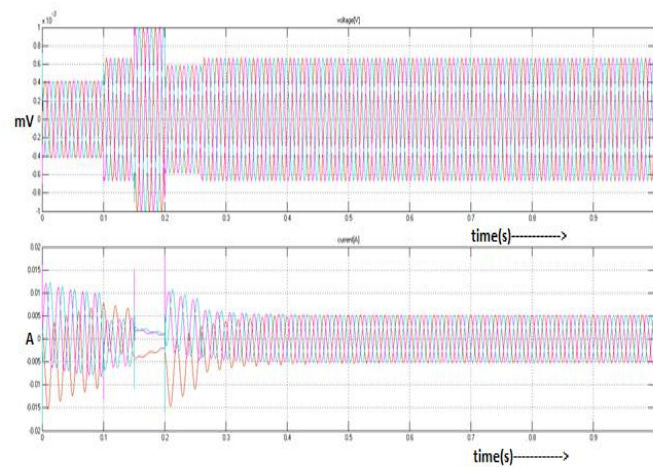

Fig-10: Output signal of DFIG based wind turbine system.

#### 4. CONCLUSIONS

A DFIG based wind turbine design has been done and the wind turbine is connected along with the grid side for a power control strategy to improve power system stability and simulated using MATLAB/Simulink. In this system, the stability is being analyzed; voltage signals are measured at various levels. The voltage and current measurement has been done at the inverter side. Damping controller has been designed for SCESS and SSSC. The output of the system was simulated and has been examine that the system requires some computational time to get stable. Future work will be of designing a wind turbine by using functional model predictive control (FMPC).

#### REFERENCES

- [1] Ramasamy M, Thangavel S. "Optimal utilization of hybrid wind-solar system as DVR for voltage regulation and energy conservation", J CircSystComput vol.23:1450062 2014.
- [2] Dhanapal S, Anita R. "Voltage and frequency control of stand alone self-excited induction generator using photovoltaic system based STATCOM", J Circ Syst Comput vol. 25(4):16500312016.
- [3] Suvire GO, Mercado PE. "Active power control of a flywheel energy storage system for wind energy applications", IET Renew Power Gener vol.6(1), pp. 9-162012.
- [4] Darabian M, Jalilvand A. "PSSs and SVC damping controllers design to mitigate low frequency oscillations problem in a multi-machine power system", J ElectrEngTechnol vol. 9(4) pp.1873-812014.
- [5] Dongkyoung C, Kyo-Beum L. "Variable structure control of the active and reactive powers for a DFIG in wind turbines", IEEE Trans IndustrApplvol. 46(6)2010.
- [6] Darabian M, Jalilvand A, Noroozian R. "The combined use of sensitivity analysis and hybrid wavelet-PSO-ANFIS to improve dynamic performance of DFIG based wind generation", J OperAutom Power Engvol. 2(1) pp.60-73 2014.
- [7] Yang L, Qstergaard Z, Dong ZY, "Wong KP. Oscillatory stability and eigenvalue sensitivity analysis of a DFIG wind turbine system", IEEE Trans Energy Convers vol. 26(1)pp. 328392011.
- [8] Taveiros FEV, Barros LS, Costa FB. "Back-to-back converter state-feedback control of DFIG (doubly-fed induction generator)-based wind turbines", Energy vol. 89 pp. 896-9062015.
- [9] Mazlumi K, Darabian M, Azari M. "Adaptive fuzzy synergetic PSS design to damp power system oscillations", J OperAutom Power Eng vol. 1(1) pp. 43-532013.
- [10] Jabr HM, Lu D, Kar NC. "Design and implementation of neuro-fuzzy vector control for wind-driven doubly-fed induction generator", IEEE Trans Sust Energy vol. 2(4)pp. 404-132011.
- [11] Gkavanoudis SI, Demoulias CS. "A combined fault ride-through and power smoothing control method for full-converter wind turbines employing Super capacitor Energy Storage System", Electr Power Syst Res vol. 106 pp.62-722014.

- [12] Hasan NS, Hassan MY, Majid MS, Rahman HA. "Review of storage schemes for wind energy systems", *Renew Sustain Energy Rev* vol. 21 pp. 237–472013.
- [13] Farzana I, Ahmed AD, Muyeen SM. "Smoothing of wind farm output by prediction and supervisory-control-unit-based FESS", *IEEE Trans Sust Energy* vol. 4(4) 2013.
- [14] Xianchao S, Yufei T, Haibo H, Jinyu W. "Energy-storage-based low-frequency oscillation damping control using particle swarm optimization and heuristic dynamic programming", *IEEE Trans Power Syst* vol.29(5)2014.
- [15] Muyeen SM, Hany M, Hasanien B, Ahmed AD. "Transient stability enhancement of wind farms connected to a multi-machine power system by using an adaptive ANN-controlled SMES" *Energy Convers Manage* vol. 78 pp. 412–20 2014.
- [16] Yong W, Jun Z. "Extended backstepping method for single-machine infinite-bus power systems with SMES", *IEEE Trans Control Syst* vol. 21(3) 2013.
- [17] Zheng W, Yuwen B, Yongqiang L, Ming C. "Improvement of operating performance for the wind farm with a novel CSC-type wind turbine-SMES hybrid system", *IEEE Trans Power Delivery* vol. 28(2)2013.
- [18] Kamel S, Jurado F, Chen Z. "Power flow control for transmission networks with implicit modeling of static synchronous series compensator", *Electr Power Energy Syst* vol. 64 pp. 911–202015.
- [19] Jean DE, Dieu NN, Godpromesse K, René KF, André C, Hilaire BF, et al. "A simplified nonlinear controller for transient stability enhancement of multimachine power systems using SSSC device", *Electr Power Energy Syst* vol.54 pp.650–72014.
- [20] Mojtaba A, Soheil G, Morteza A. "Wavelet neural adaptive proportional plus conventional integral-derivative controller design of SSSC for transient stability improvement", *EngApplArtifIntell* vol.26 pp.2227–422013.
- [21] Bangjun L, Shumin FA. "Brand new nonlinear robust control design of SSSC for transient stability and damping improvement of multi-machine power systems via pseudo-generalized Hamiltonian theory", *Control EngPract* vol. 29 pp. 147–572014.
- [22] Rajendra KK, JitendriyaKS. "Time delay approach for PSS and SSSC based coordinated controller design using hybrid PSO–GSA algorithm", *Electr Power Energy Syst* vol.71 pp.262–732015.
- [23] Sidhartha P, Narendra KY, Sangram KM. "Hybrid BFOA–PSO approach for coordinated design of PSS and SSSC-based controller considering time delays", *Electr Power Energy Syst* vol. 49 pp. 221–332013.
- [24] Dinh-Nhon T, Van-Thuyen N. "Designed damping controller for SSSC to improve stability of a hybrid offshore wind farms considering time delay", *Electr Power Energy Syst* vol.65 pp. 425–312015.
- [25] Wang Li, Quang-Son V. "Power flow control and stability improvement of connecting an offshore wind farm to a one-machine infinite-bus system using a static synchronous series compensator", *IEEE Trans Sust Energy* vol. 4(2)2013.
- [26] Camponogara E, Scherer HF. "Distributed optimization for model predictive control of linear dynamic networks with control-input and output constraints", *IEEE Trans AutomSciEng* vol. 8(1) pp.233–422011.
- [27] Zong YI, Kullmann D, Thavlov A, Gehrke O, Bindner HW. "Application of model predictive control for active load management in a distributed power system with high wind penetration", *IEEE Trans Smart Grid* vol. 3 pp. 1055–622012.
- [28] Evans MA, Mark C, Basil K. "Robust MPC tower damping for variable speed wind turbines", *IEEE Trans Control SystTechnol* vol. 23 pp. 290–62015.