

SMART HELMET

Vrushali Patil¹, Snehal Jadhav², Shraddha Burande³, Sharavarya Patil⁴

¹Professor, Dept. of Electronics and Telecommunication Engineering, AITRC, Vita, Maharashtra, India

^{2, 3, 4} Dept of Electronics and Telecommunication Engineering, AITRC, Vita, Maharashtra, India

Abstract - Now a day's occurrence of accidents on two wheeler is increasing. So safety and security become most essential while riding on bike. For this safety of life the bike rider should use the helmet while driving. In many countries the helmet becomes compulsory to avoid the unexpected accidents. Our smart helmet system works on it. In this system if the driver wears the helmet, then and then only the bike will start. Another main reason to cause the accident is drunk and Drive. So our system avoids the driving with drunken condition. After wearing the helmet, the system checks that the driver is drunk or not, and then sends that message to the registered number through GPS and GSM mounted in helmet. Main purpose of this system is accident detection. It detects the location of accident of bike by GPS and sends this message to respective people through GSM.

Key Words: Arduino, Microcontroller, GPS/GSM Modem, Sensors, RF Transmitter, RF receiver.

1. INTRODUCTION

In recent times helmets have been made compulsory in Maharashtra State because Traffic accidents in India have increased now. In India drunken driver case is a criminal offence of The Motor Vehicle act 1939. By this act the bike rider will get punish if drive in drunken condition. The thought of developing this project comes for escaping people from this law. Now a day the amount of two wheeler accidents are increasing and cause loss of many lives. According to a survey of India there are around 750 accidents taking place due to bike crashes per year. So the main reasons behind the accidents are unsafe driving, consuming alcohol while driving. Some time the person injured by accident, there may be fault of rider. This is a situation we observe our day to day life. Considering major factors for avoiding the accident causes such as make wearing the helmet compulsory and avoid 'drunk and drive'. The major reason was found to be the absence of helmet on that person's head, resulting in an immediate death due to brain damage. This system gives idea or information about the rider wearing the helmet or not, whether the rider drunken or not and also, when accident occurs, it gives an information about location where he is met with an accident through GSM module to respective mobile numbers of family members. So for this purpose we have chosen GSM technology to give the information by sending SMS, using GSM module.

Only SMS saying accident is occurred can't help the ambulance to reach to rider. The ambulance have to know where the accident is occurred. So to track the location where exactly accident occurred, GPS module is used and it gives signal to Arduino, then it sends the SMS which contains the latitude and longitude of a area to mobile numbers registered in GPS. For this we use GPS module to extract the location of the accident, the GPS data will contain the latitude and longitude values of the location. By using those values we can find the accurate position of the accident place.

1.1 Need of project

1. To design smart helmet for overall rider.
2. To point the route that it increase the safety of motorcyclists.
3. To mean system that reduces the passing of go due to behind schedule arrival of the ambulance.

2. Literature survey

The advent of technology has also increased the traffic hazards and the road accidents take place frequently which causes huge loss of life and property because of the poor emergency facilities. This project provides an optimum solution to this draw back. An accelerometer can be used in a car alarm application so that dangerous driving can be detected. It can be used as a crash or rollover detector of the vehicle during and after a crash. According to this project when a vehicle meets with an accident immediately Vibration sensor will detect the signal or if a car rolls over, and Micro electro mechanical system (MEMS) sensor will detects the signal and sends it to ARM controller.

Microcontroller sends the alert message through the GSM MODEM including the location to police control room or a rescue team. So the police can immediately trace the location through the GPS MODEM, after receiving the information. Then after conforming the location necessary action will be taken. If the person meets with a small accident or if there is no serious threat to anyone's life, then the alert message can be terminated by the driver by a switch provided in order to avoid wasting the valuable time of the medical rescue team. This paper is useful in detecting the accident precisely by means of both vibration sensor and Micro electro Mechanical system (MEMS) or accelerometer [1].

The traffic authorities give a lot of instructions to the vehicle operators. But many of them do not obey the rules. Nowadays most of the countries are forcing the motor riders to wear the helmet and not to use the vehicles when the person is in drunken condition. But still the rules are being violated by the users. In order to overcome this we introduces an intelligent system, Smart Helmet, which automatically checks whether the person is wearing the helmet and has non- alcoholic breath while driving [2].

As the bikers in our country are increasing, the road mishaps are also increasing day by day, due to which many casualties, most of them are caused due to most common negligence of not wearing the helmets, and also many deaths occur due to lack of prompt medical attention needed by the injured person. This motivates us to think about making a system which ensures the safety of biker [3].

BLOCK DIAGRAM AND DISCRPTION

2.1 Block Diagram:

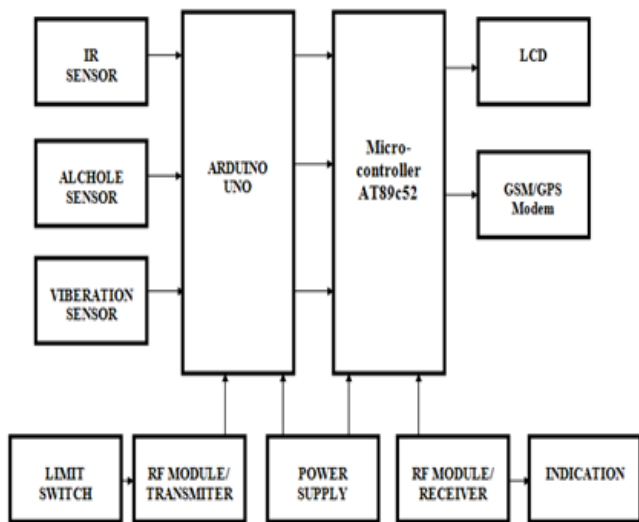

FIG: BLOCK DIAGRAM

2.2 Block Diagram Description:

This module contains common sensors and transmitter circuitry. Microcontroller contains three sensors which are alcohol sensor, IR sensor and vibration sensor has been utilized to concede the alcohol focus. The alcohol sensor will be put intimate to the swagger of rider, inside the helmet. Vibration sensor utilize for break down location. The RF transmitters which consist transmit information from any controller. The RF transmitter information from controller to the receiver to transmitting antenna.

This installation done with wireless communication. This accepts information from receiving antenna then information send it to the microcontroller for further handling. In the coming of an accident, the GPS module will expand the co-ordinates of smash site. These co-ordinates are send by means of GSM module to a pre definite number. The person who belongs to this number receives the detection of accident location with the help of GPS and sending SMS through the GSM module. LCD is used to show the situation of sensors activities.

The helmet consists of Arduino uno, IR sensor, Vibration sensor, Alcohol sensor at transmitter side. First sensor IR sensor which measure the distance of the adjoin heartbreaking vehicle. IT locates the vastness between vehicles, at the time of serious position. Second sensor is alcohol sensor which utilize to find out alcohol subject this mainly used for prevent accident. The quality is in drunken condition sends information to receiver that time bike decreases the velocity at that moment befall to off status with the help out of RF receiver. Also the Vibration sensor used for detect smash at the time of analytical situation this sends information to receiver and letter to predefined number like the qualities is in trouble.

3. Application, Advantages and Future scope:

3.1 Application

1. It can be used real time safety system.
2. Public and commercial security.
3. Help to protect life in accident case.

3.2 Advantages:

1. Number of cases of violated traffic rules can be reduced.
2. Good thing to handle being in crash case.

3.3 Future Scope:

1. We can use solar panel for helmet power supply. Battery can be replaced by solar panel as a power supply in helmet.
2. We can manufacture the whole circuit in printed circuit board to reduce the size and can be easily fitted into helmet.

4. Result:

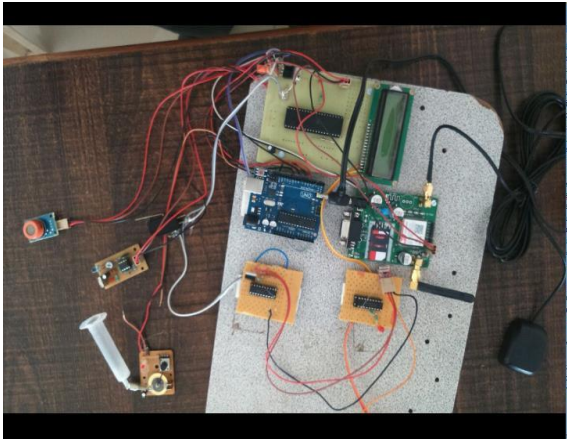

5. CONCLUSIONS

This system is useful for the safety function of the user. Client has to hold helmet to be carried two wheeler vehicles. And that's why We will follow traffic rules. This system is travel two wheeler vehicle having protection in pass and in funds also. It is easy to handle this system. It provides a improve self-confidence to the biker.

6. References:

- [1] Sudharsana Vijayan, Vineed T Govind ,Merin Mathews, "Alcohol Detection Using Smart Helmet System,"vol.8,pp.2014.
- [2] Jazim Baramy , Pragya Singh , Aryasheel Jadhav , Krutikesh Javir, " Accident Detection & Alerting System,"pp.2016.
- [3] Jennifer William, Kaustubh Padwal, Nexon Samuel, Akshay Bawkar, "Intelligent Helmet,"vol. 7,pp.2016.
- [4] Prof. Chitte P.P. , Mr. Salunke Akshay S. , Mr. Thorat Aniruddha N. " Smart Helmet & Intelligent Bike System,"vol.03,pp.2016.
- [5] Karthik A, Karan GB, Kiran Pai, Srinivas A., "SMART HELMET," pp. NCPD 2016 .