

HYBRID ENERGY SYSTEM USING NON ISOLATED DC –DC CONVERTER

A.MONISHA¹, N.PADMAVATHI², N.RAVEENA³, J.SUGANTHI⁴, D.SHOBANA ⁵

^{1,2,3,4} Student, Electrical and Electronics Engineering, Panimalar Institute of Technology, Chennai, TN

⁵Assistant Professor, Electrical and Electronics Engineering, Panimalar Institute of Technology, Chennai, TN

Abstract – Because of the discontinuous component of sustainable power source, vitality stock piling (energy storage) units are required keeping in mind the end goal to adjust the power age and utilization. Interface circuit is the integral part of the vitality stockpiling framework. Our venture is executing a non-isolated dc-dc converter for the photovoltaic and wind framework. The proposed non-isolated dc-dc converter is utilized to interface photovoltaic cells (PV), wind source and load independently. The circuit topology is determined by incorporating a few parallel Boost converters. The non-isolated dc-dc converter can understand vitality bidirectional stream among PV, wind source and load.

Key Words: Four-port dc-dc converter, hybrid strength storage gadget, energy bidirectional drift.

1. INTRODUCTION

Photovoltaic strength technology gadget is usually affected via weather and different outside elements, and it desires to cooperate with electricity garage device to improve the efficiency of the device. The hybrid strength storage device is broadly used inside the impartial photovoltaic electricity technology system as it can make full of use of the benefits of different strength garage medium. The structure of the conventional hybrid strength storage device based on battery and super capacitor because the electricity storage tool is proven in Fig.1. The shape includes two-level DC-DC converters between photovoltaic cells and strength garage medium. The front level is a boost converter. It is used to accomplishing the most energy point tracking (MPPT) control of photovoltaic cells. And the later degree is two bidirectional DC-DC converters in parallel connected with the battery and the super capacitor respectively. It is used to accomplishing bidirectional glide and maintaining the DC bus voltage balance [1, 2]. Multiport converter can lessen the quantity of circuit devices and gadget length, weight, cost with the aid of sharing transfer devices or different additives. Therefore, it's far used in the satellite power discipline, DC micro-grid gadget and hybrid electric car. The topology of modern-day 3-port converters is introduced in paper [3]. In [4] and [5], a non-isolated integrated 3-port converter in satellite TV for pc power systems has been proposed, it makes use of country space averaging technique to establish the small sign

mathematical version of the 3-port converter, and proposes the design method of compensator on this basis.

However the manipulate does no longer do not forget MPPT of photovoltaic cells, the efficiency is not foremost. In [6-8], Modeling and optimizing manage of a isolated 3-port 1/2-bridge converters, the feasibility of the converter in every model is proven by way of experiments. But, this isolated topology includes a high frequency transformer, which will increase the wide variety of switches and enlarges gadget volume. The paper [9] puts forward an improved approach about a frequency dividing coordinated control strategy of traditional hybrid electricity garage system, enhancing the garage performance. Though, the electricity conversion of the gadget is still two levels, the efficiency isn't always excellent. On this paper, a non-isolated dc-dc converter for hybrid energy storage machine is proposed. It's miles optimized through the mixture of the basic circuit, as opposed to the conventional two-stage DC-DC converters. This converter can realize the hybrid energy garage and make sure the stableness and green operation of the gadget. First off, the generation system of the non-isolated 4-port dc-dc converter is defined. Then, each operation mode of the converter below exclusive circumstances is explicated in detail, the mathematical model set up respectively. Finally, the feasibility of the non-isolated dc-dc converter is confirmed via simulation.

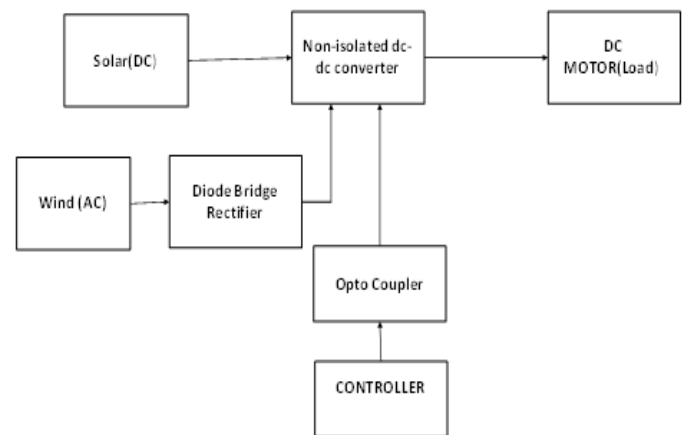

Fig-1: Block Diagram

2. NON-ISOLATED CONVERTER

2.1 Converter derivation

In this paper, a non-isolated dc-dc converter for photovoltaic and wind energy storage framework is proposed. It is upgraded by the mix of the essential circuit, rather than the customary two-arrange DC-DC converters. This converter can implement the non-isolated and guarantee the stable operation and effective activity of the framework. The converter can accomplish bidirectional stream, as well as can understand the greatest power point following (maximum power point tracking) control of photovoltaic cells. It is optimized by the combination of a three-parallel Boost circuit and a dual output Boost circuit [11].

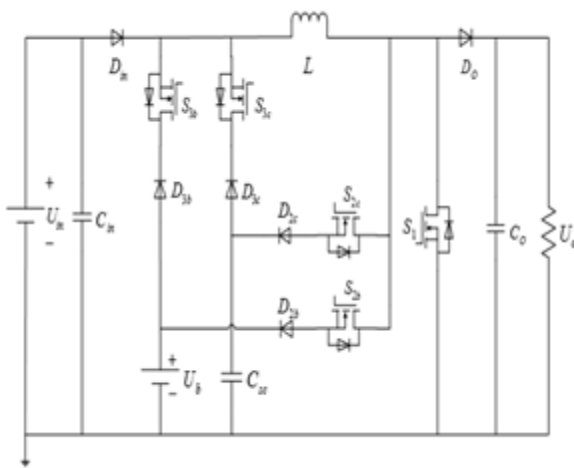

Fig.2: Non-isolated dc-dc converter structure

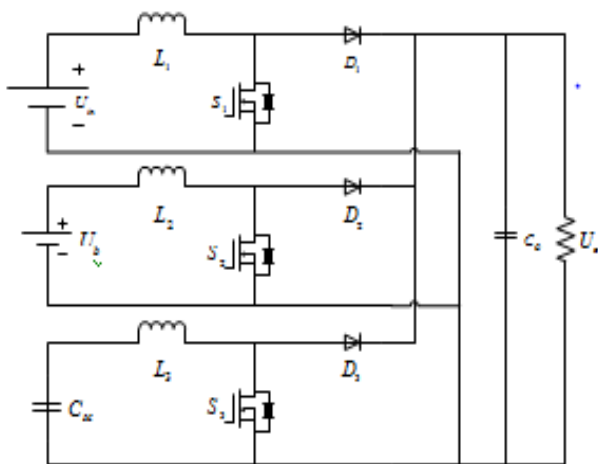

Fig.3: The three-parallel Boost circuit

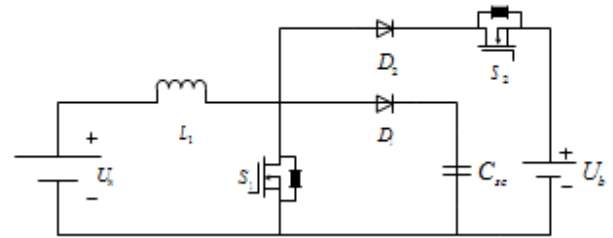

Fig.4: The dual output Boost circuit

2.2 Converter operation principle

As per the connection between the yield energy (output power) of the hybrid input and the required energy of the load, the dc-dc converter can work in three diverse operating modes. They are the double output mode, the double input mode and the single input single output mode.

2.2.1 Dual Output Mode

At the point when the output energy of hybrid system is more than the required energy of the load, the photovoltaic cells port gives power to the load, as well as charges to the battery and the super capacitor, the case is called dual output mode. In this mode, the power switch tube S3b, S3c dependably keep off state, the power switch tube S1, S2b, S2c keep activity to adjust the battery and the super capacitor charging and keep up the DC voltage steady.

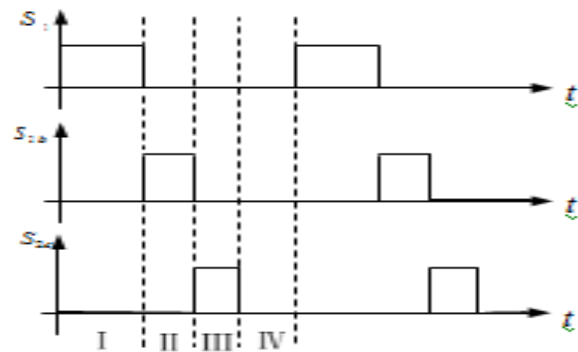

Fig.5: Pulses for Dual Output Mode

2.2.2 Dual Input Mode

At the point when the output energy of hybrid system is not as much as the required energy of the load, the photovoltaic cells port gives energy to the load, then the battery and the super capacitor gives energy to the load by

releasing, the case is called dual input mode. In this mode, the power switch tube S2b, S2c dependably keep off state, the power switch tube S1, S3b, S3c keep activity to alter the battery and super capacitor releasing and keep up the DC voltage consistent.

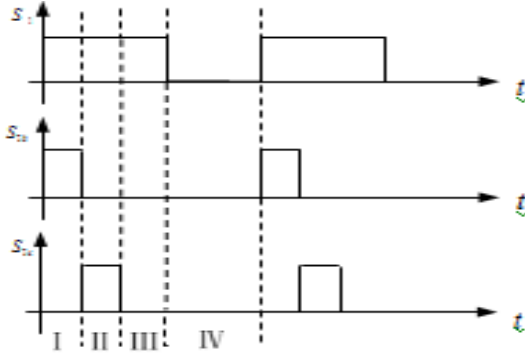

Fig.6: Pulses for Dual Input Mode

2.2.3 Single Input Single Output Mode

At the point when the yield energy of hybrid system is very nearly zero, just the battery and super capacitor give energy to the load by releasing, the case is called single input single output mode. In this mode, the power switch tube S2b, S2c dependably keep off state, the power switch tube S3b, S3c dependably keep up an integral activity state, just switch tube S1 works in switch activity. Amid the task, the battery and the super capacitor give energy to the load port by releasing and keep up the DC voltage consistent. Its activity standard is like the normal Boost circuit.

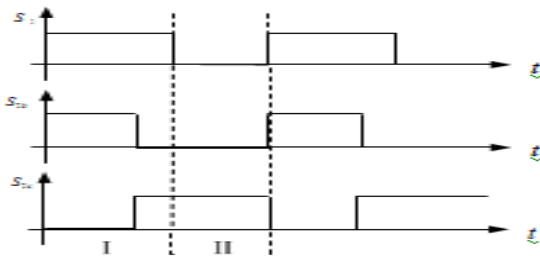

Fig.7: Pulses for Single Input and Single Output Mode

3. SYSTEM CONTROL STRATEGY

Photovoltaic cells are influenced by the outside variables such as light intensity, temperature etc, which causes its output voltage and power have a specific fluctuation. For the incorporated non-isolated dc-dc converter proposed in this paper, it can guarantee the framework stability in the extraordinary outer condition. The converter can not just accomplish bidirectional stream, yet in addition can implement the maximum power point tracking control of

hybrid system. The structure of the framework closed loop control is appeared in Fig.8. The outer impact will cause high frequency and low frequency fluctuations. It is more sensible to isolate the voltage fluctuations of the framework.

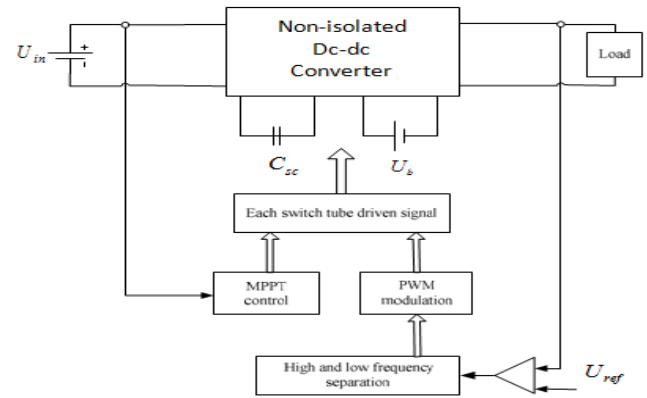

Fig.8: System closed loop control structure

In this paper, the perturbation and observation method is chosen to implement the MPPT control of the photovoltaic cells. The first order low pass filter is utilized for isolating the high and low frequency fluctuations. The low frequency fluctuations are consumed by the battery, and the high frequency fluctuations are consumed by the super capacitor. The frequency separation control diagram is given in Fig.9. The power switch tube S1 chiefly understands the MPPT control, the power switch tube S2b, S2c, and the power switch tube S3b, S3c separately reciprocally work to accomplish the output voltage stable.

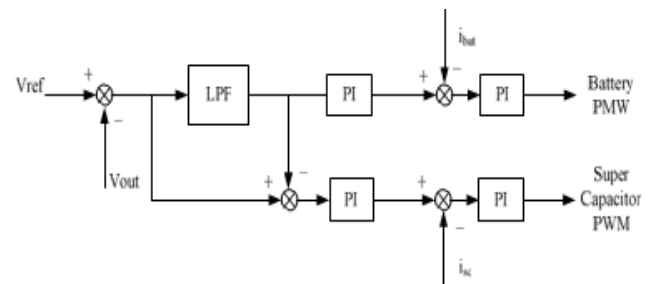

Fig.9: Frequency separation control chart

4. SIMULATION VERIFICATION

In this paper, the non-isolated dc-dc converter is connected in the autonomous hybrid energy storage framework, and the entire framework display is worked in MATLAB. The input voltage is 100 volt. The each port voltage waveforms of the system in the dual output mode, the dual input mode, the single input single output mode are shown in Fig.10 - Fig.19 respectively. MATLAB R2013a is used for simulation.

4.1 Simulation of the photovoltaic System

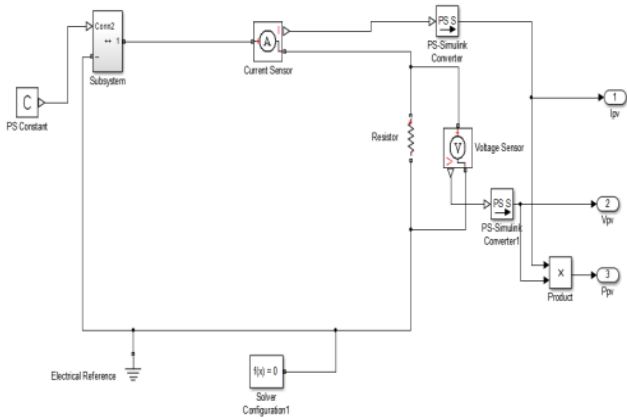

Fig.10: Simulation of PV

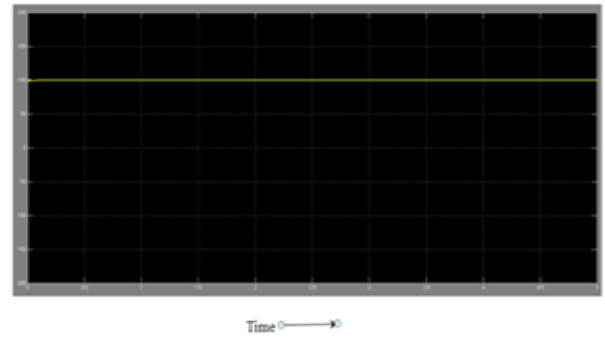

Fig.13: Output voltage waveform generated from the Wind energy

4.3 Simulation of dual output mode operation

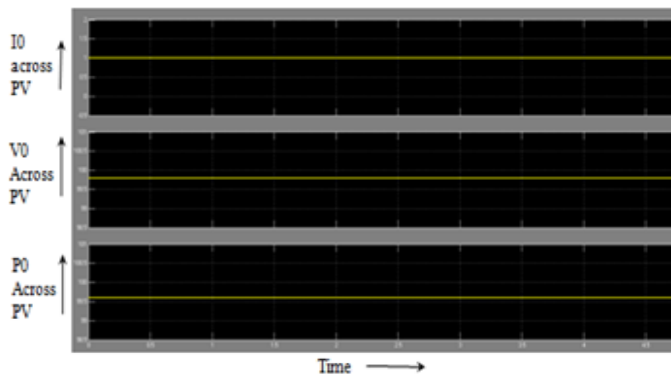

Fig.11: Output current, voltage and power waveform of the PV

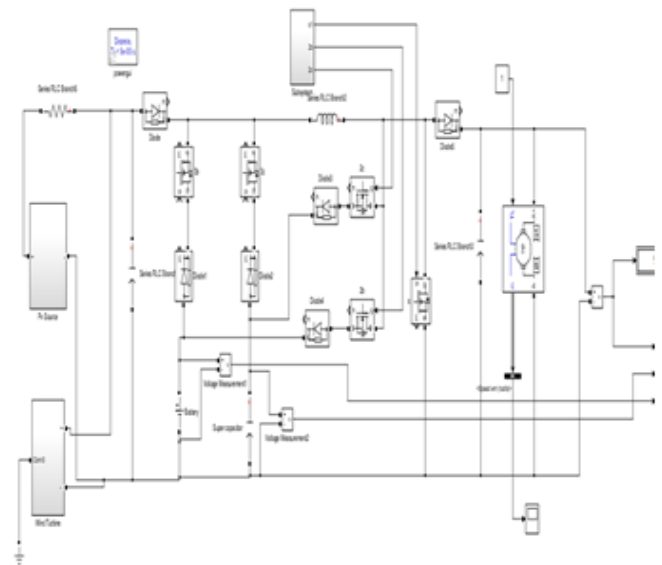

Fig.14: Simulation at dual output mode

4.2 Simulation of the wind system

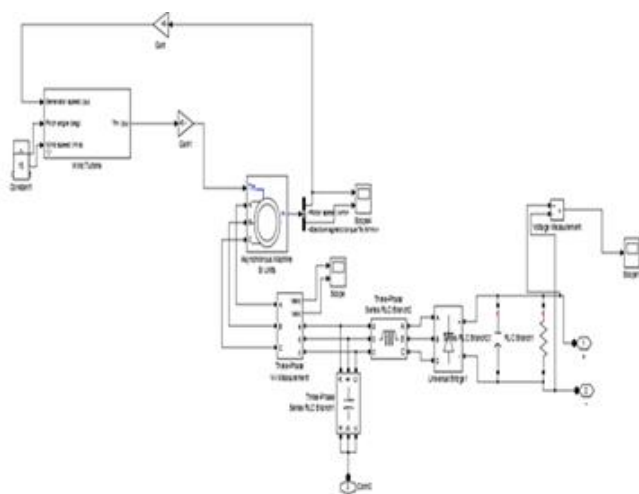

Fig.12: Simulation of Wind Energy

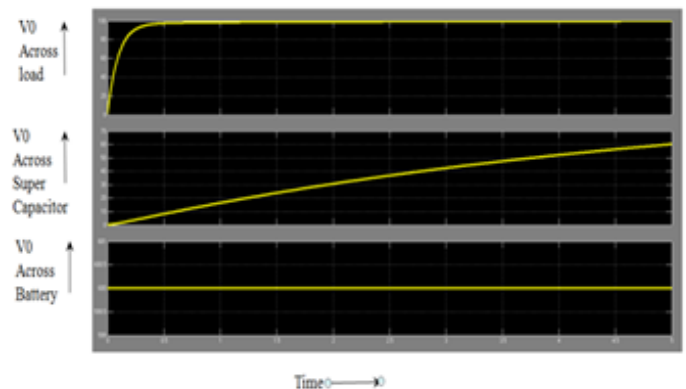

Fig.15: Output voltage waveform of dual output mode across the load, super capacitor and battery with PV and wind Energy source

4.4 Simulation of dual input mode

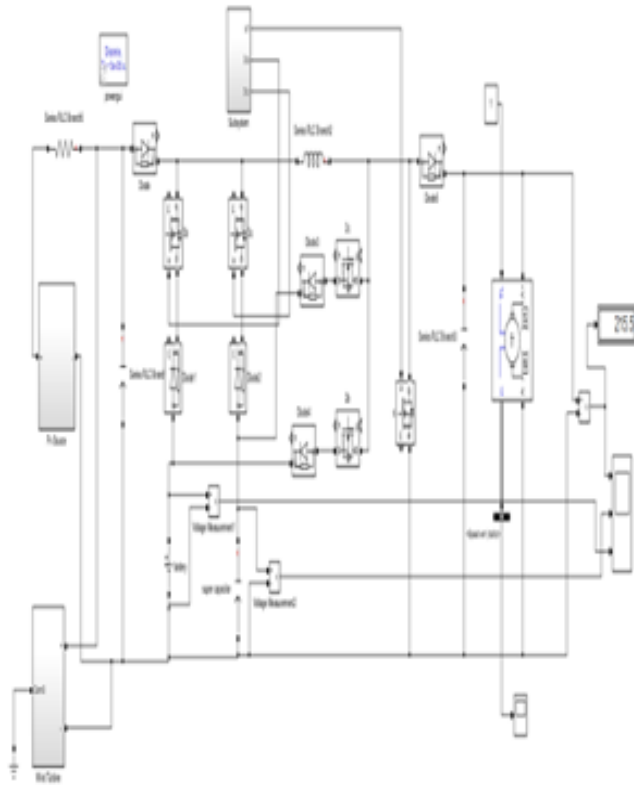

Fig.16: Simulation Of non-isolated converter at dual input mode

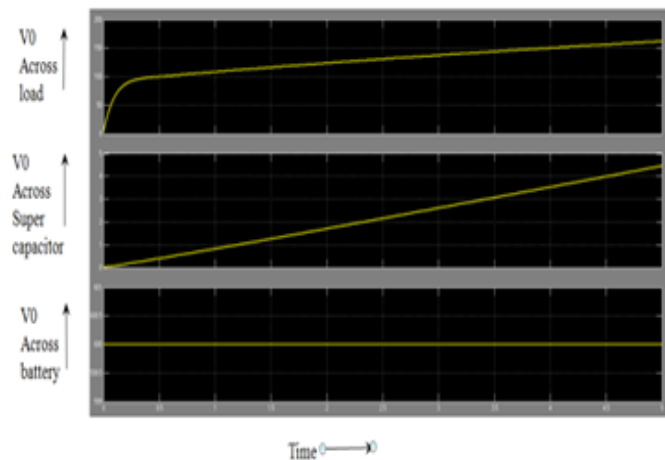

Fig.17: Output voltage waveform of dual input mode across the load, super capacitor and battery with PV and wind Energy source

4.5 Simulation of single input single output mode

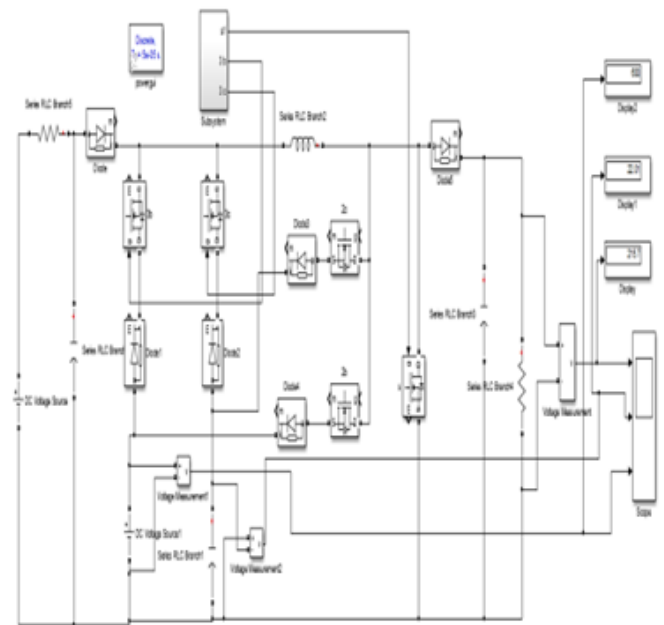

Fig.18: Simulation Of non-isolated converter at single input and output mode

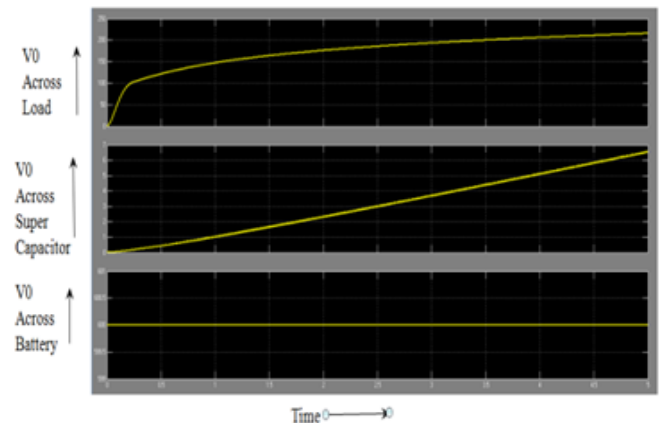

Fig.19: Output voltage waveform of single input and output mode across the load, super capacitor and battery with PV and wind Energy source

CONCLUSION

The non-isolated dc-dc converter has the upsides of little size and high proficiency. It can also implement the bidirectional stream and the greatest power point following control (maximum power point tracking) of the hybrid input system just by single stage change. Joined

with the qualities of the super capacitor and the battery, the converter can sensibly disseminate the energy of the framework. In the meantime, it can guarantee the output voltage of the load port steady under different conditions, and can guarantee the solid and effective activity of the framework.

REFERENCES

1. H. Wu, K. S. Ding, and Y. Xing, "Topology derivation of nonisolated three-port DC-DC converters from DIC and DOC," *IEEE Trans. Power Electron.*, vol. 28, no. 7, pp. 3297-3307, Jul. 2013.
2. Z. Qian, O. Abdel-Rahman, H. Al-Atrash, and I. Batarseh, "Modelling and control of three-port dc/dc converter interface for satellite applications," *IEEE Trans. Power Electron.*, vol. 25, no. 3, pp. 637-647, Mar. 2010.
3. H. Wu, R. Chen, J. Zhang, Y. Xing, H. Hu, and H. Ge, "A family of three-port half-bridge converters for a stand-alone renewable power system," *IEEE Trans. Power Electron.*, vol. 26, no. 9, pp. 2697-2706, Sep. 2011.
4. A. Nami, F. Zare, A. Ghosh, and F. Blaabjerg, "Multi-output DC-DC converters based on diode-clamped converters configuration: Topology and
5. W. Xu, Y. Li, X. Gong, Z. Hong, and D. Killat, "A dual-mode single-inductor dual-output switching converter with small ripple," *IEEE Trans. Power Electron.*, vol. 25, no. 3, pp. 614-623, Mar. 2010.
6. C.-S. Huang, D. Chen, C.-J. Chen, and K. H. Liu, "Mix-voltage conversion for single-inductor dual-output buck converters," *IEEE Trans. Power Electron.*, vol. 25, no. 8, pp. 2106-2114, Aug. 2010.
7. Jinyang Gao, Guozheng Yan "A Novel Power Management Circuit Using a Super-Capacitor Array for Wireless Powered Capsule Robot" *IEEE-ASME TRANSACTIONS ON MECHATRONICS*
8. Haimin Tao, Andrew Kotsopoulos, Jorge L. Duarte, Member, IEEE, and Marcel A. M. Hendrix, Member, IEEE "Transformer-Coupled Multiport ZVS Bidirectional DC-DC Converter With Wide Input Range" *IEEE TRANSACTIONS ON POWER ELECTRONICS, VOL. 23, NO. 2, MARCH 2008*
9. Nicholas D. Benavides, Student Member, IEEE, and Patrick L. Chapman, Senior Member, IEEE "Power Budgeting of a Multiple-Input Buck-Boost

Converter" *IEEE TRANSACTIONS ON POWER ELECTRONICS, VOL. 20, NO. 6, NOVEMBER 2005*

10. Zhixiang Ling, Hui Wang, Kun Yan, Zaoyi Sun "A New Three-port Bidirectional DC/DC Converter for Hybrid Energy Storage" *Future Energy Electronics Conference (IFEEEC), 2015 IEEE 2nd International*
11. A. Di Napoli, F. Crescimbeni, L. Solero, F. Caricchi, F. Giulii Capponi "Multiple-Input DC-DC Power Converter for Power-Flow Management in Hybrid Vehicles" *Industry Applications Conference, 2002. 37th IAS Annual Meeting.*
12. Gui-Jia Su, Fang Z Peng "A Low Cost, Triple-Voltage Bus DC-DC Converter for Automotive Applications" *Applied Power Electronics Conference and Exposition, 2005. APEC 2005*
13. Zhijun Qian, Osama Abdel-Rahman, Kejiu Zhang, Haibing Hu, John Shen, Issa Batarseh "Design and analysis of three-port DC/DC converters for satellite platform power system" *Energy Conversion Congress and Exposition (ECCE), 2011 IEEE*
14. Zhijun Qian, Osama Abdel-Rahman, Justin Reese, Hussam Al-Atrash, Issa Batarseh "Dynamic Analysis of Three-Port DC/DC Converter for Space Applications" *Applied Power Electronics Conference and Exposition, 2009. APEC 2009. Twenty-Fourth Annual IEEE*
15. Ghulam Fareed Laghari, Adnan Umar, Suheel Abdullah "Comparative analysis of multi-input DC/DC converter topology for hybrid renewable energy systems" *Power Generation System and Renewable Energy Technologies (PGSRET), 2015*

BIOGRAPHIES



A. Monisha,
Department of Electrical and
Electronics Engineering,
Panimalar Institute of
Technology,
Chennai.



N. Padmavathi,
Department of Electrical and
Electronics Engineering,
Panimalar Institute of
Technology,
Chennai.



N.Raveena,
Department of Electrical and
Electronics Engineering,
Panimalar Institute of
Technology,
Chennai.



J.Suganthi,
Department of Electrical and
Electronics Engineering,
Panimalar Institute of
Technology,
Chennai.