

AUTOMATIC TRANSFER SWITCH FOR POWER GENERATOR

Harish T. Wakudkar¹, Prajwaleet V. Mawale², Anand A. Kamble³, Prof. S. J. Tikhe⁴

^{1,2,3} UG Students, Electrical Engineering, DES'sCOET, Dhamangaon Rly, Maharashtra (India)

⁴ Assistant Professor, Electrical Engineering, DES'sCOET, Dhamangaon Rly, Maharashtra (India)

Abstract - The automatic transfer switch is helpful transfer the load from various power sources to ensure continuous operation of load. Automatic transfer switch is needed in developing countries where frequent power failure is a major problem. Industries, public and private sector organization and even domestic user cannot handled power outage due to it pushes them in loss in business disturbance in normal official work, hindrance in routine and domestic life. In this system we have highlighted the use of good border in term of switching speeds and smooth evolution. Allowable by means of an automatic connection to a network of other sources of supply in case the main source of power supply distress. The automatic transfer switch which is a switchgear control system, provides a functional system that offers an automatic switching of power supply between a primary source and secondary source is generator. The method laboring in designing the automatic transfer switch include the use of electromechanical relay, contactor, voltage monitoring relay and delay timer relays as main component of the system.

Key words: Circuit Breaker, Contactor, Relay, Voltage Monitoring Relay, etc

1. INTRODUCTION

The poor state of power supply in developing countries, calls for replacements sources of power generation and automation of electrical power generation to back up the utility supply. Over time, automation of electrical power supply has become so vital as the rate of power outage is principally high. As a result of this power outage, developing countries, experience slow development processes in both the public and private sectors of their economy.

Therefore, it is for these causes that change over or transfer switches were developed. An automatic transfer switch is used to switch the load between two powers supplies are down of any one of them connected to the load. It makes assured the supply of power to the load with minimum minor gap between the power failure and reconnecting the load to secondary power supply. The automatic transfer switch is connected between load and the power supplies. Its function is to transfer the load from primary source of electricity or public main power supply on its failure to secondary source of electricity or generator and then transfer the load back to mains supply when it reestablishes. The function of an automatic transfer switch is to check the input mains if it is present or not present. If main supply is absent, the switch starts the generator and transfers the load to it. It is therefore also named generator transfer switch.

Automatic transfer switch is also called as "Generator Transfer Switch", its main function is to detect the absence of mains supply and switch the load to the secondary supply and vice versa, potential transformers and current transformers are used to measure the current drawn by the load so that the energy can be managed.

Therefore, it is for these reasons that transfer switches were established. Initially, these switches were designed for manual operations, but with an growth in the technological advancement of electrical power control, Automatic transfer switches were shaped. It removes the element of user contact in starting a generator and changing power supply from one source to another. Some of the methods which have been occupied to implement change over system include manual change over switch box, automatic change over system with electromechanical relays, contactor, circuit breaker and change over system with automatic transfer switch. Respectively of these methods have some drawbacks that make it unwanted. These contribute to the high cost of these method.

2. Block Diagram

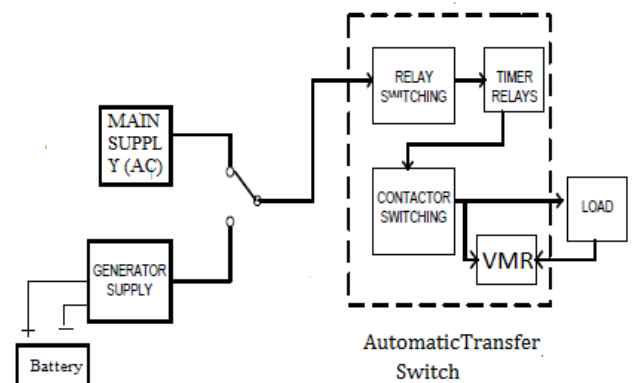

Fig.1. Block Diagram of Automatic Transfer Switch For Power Generator

The voltage monitoring and control circuit are designed and constructed. This was accomplished by using voltage monitoring relay (VMR) as an initial component of the power sensing and control circuit. This is used for measuring and comparing the voltage level of the main supply with the set of voltage range (230 volts) influence a 12 ampere miniature circuit breaker (MCB) will act as a switch to the power supply from the main supply end of the automatic transfer switch. The power switching it can design the circuit. Ideal

type power contactor rated 60amp, 230 volts a. c. timer delay to supply the delays (10 seconds) through the starting of the generator and transfer of the connected load vice versa from both power is depending on the side with stable electrical power at any point in time are used. A switching mechanism of the generator is done with by the battery supply 12 volt d. c. and contact of the timer relay and contactor. The automatic start and stopping of the generator depending on whether the contactors are energized and de-energized. The voltage monitoring unit is too displayed by the main supply voltage and generator supply voltage.

3. Steps of Block Diagram

3.1 Relay Switching Stage: This block is consist of the arrangement of the voltage monitoring relay and the identifier relay which serve as the sensor used to choose the availability or no availability of the voltage supply from also power sources until triggering the control section of the automatic transfer switch. The voltage monitoring relay is used for comparing and measuring the voltage level of main supply with a set voltage is in rage 230 volt.

3.2 Timer Relay Stage: This block is made by the delay timer relay operating as generally open time closed timer relay on all section of the automatic transfer switch. The timer relay on the main section helps to delay the supply of electric power from the main supply, thus checking the occurred electrical harm due to fluctuation in supply. The timer relay on the generator section helps fix the power generator and permits it to warm-ups before it finally supplying the power to the connected load. The delay time for the main timer relay is 10 seconds while that of the generator is about 15 seconds.

3.3 Contactor Switching Stage: This block is made of the contactor on each side of the automatic transfer switch its mean by main supply contactor and generator side contactor. The function of a contractor is to switch the current to the connected load simply. Because they have made to knob a large amount of current flow in electrical fixing. The more load rating of the contactor is 0ampere.

3. CONCLUSION

The manual start and stop and transfer the on generator can static used after the addition of the automatic controller. It can engross the self-start generator at the start of the power failure. The total cost of the automatic transfer switch is very low. Automatic transfer switch has the capability is to control and switch between the power sources in minimum seconds. It is also relief for starting a standby power generator when there is power failure from mains without the necessity for human effort. The system work is satisfactory with respect to design specification.

REFERENCES

- [1] Hamed, Lasisi, Oladokun Ajibola Samson, "Elimination of Stress and Reduction in Switching Time from Mains to Back-Up Power Source in Power Dependent Public Utilities by Automatic Mains and Phase Changer", International Journal of Engineering Sciences & Research Technology, Vol. 3, 2014/April.
- [2] Hotchkiss, Ronald W., "Surge Protection of Automatic Transfer Switches Application Note", PES General Meeting Conference & Exposition, IEEE 2014.
- [3] J. G. Kolo, "Design and Construction of a Single Phase Automatic Change-Over Switch", Department of Electrical and Computer Engineering, Federal University of Technology Minna, Nigeria, 2007.
- [4] M.S Ahmed, A.S Mohammed and O.B. Agusiobo, "Development of a Single phase Automatic Change-Over Switch", Department of Electrical and Computer Engineering, Federal University of Tec`hnology Minna, Nigeria, July 2006.
- [5] M. QaisarAzeem, Habib-ur-Rehman, ,Sheeraz Ahmed, AmjadKhattak, "Design and Analysis of Switching in Automatic Transfer Switch for Load Transfer", IEEE International Conference on Open Source Systems and Technologies (ICOSST) 2016, Page no. 129-134.
- [6] Olatomiwa, Lanre, and Rasheed Olufadi. "Design and development of a low cost automatic transfer switch (ATS) with an over-voltage protection.", Journal of Multidisciplinary Engineering Science and Technology.