

Gas Leakage Detection and Prevention Kit Provision with IoT

Manaswi Sharma¹, Diksha Tripathi¹, Narendra Pratap Yadav¹, Parth Rastogi¹

¹U.G. Student, Department of Electronics and Communication Engineering, IMS Engineering College, Ghaziabad, U.P., India

Abstract - For the sake of lives safety and fulfillment of social duties, and keeping in focus the life-threatening instances of blasts and injuries due to leakage of gas in industries, vehicles and houses, a gas leakage system has been designed whereby application of embedded systems and involvement of Internet of things (IoT) in it, a system is obtained that enables us not only to notify the concerned person but also seize any leakage of gas. In the paper, a system has been proposed which lessen the chances of accidents and ensure safety by the virtue of existing electronics and technology.

Key Words: (MQ-6 Gas sensor, Internet of Things (IoT), Microcontroller (MCU), C2000 Piccolo MCU, LCD (Liquid crystal display), Wi-Fi module, USP (Unique Selling Point).

1. INTRODUCTION

Embedded systems described as, 'a computer system with a dedicated function within a larger mechanical and electrical systems, often with real-time constraint'^{[1][2]}, are being employed to detect the excess of gas in the marked environment.

This gas detection and alert system will not only alert us of the leakage but will also mechanically turn off the knob of the gas cylinder to seize any leakage of gas. Moreover, this system informs the concerned person by emailing and dropping a message on their mobile. This gives a larger degree of safety to any gas setup in any circumstances.

Nowadays, as the lives of people have to fasten, their attention has got divided into multiple areas, in such a case people might forget to take all the necessary measures while cooking and leave the stove's burner on or the knob of the regulator lose, which could be dangerous, the severity of the deed increases majorly when this carelessness is seen in industrial areas with the gas plants or engines. For any flammable substance to be present in the site and coming in contact with the gas can cause a blast, asset loss, life loss, resource wastage and the list only adds. The major sectors under continuous danger are industries, automobiles like a car, buses etc and also at places where it is processed and handled.

This system is a compact version for the facilitation of safety as it involves many mini-features of mega significance and holds a USP of automatic gas shutting feature, in case of absence of any human help in the area of leakage this

feature is of great significance. There are many examples of life accidents due to leakage of gases; recently in Attayampatti village about 25 km from Salem, occurred, where five people left dead, incidents like these increases the need of such systems.

Many papers^{[6][7][8]} are published on gas leakage detection in which gas sensors are used for detection of leakage and also providing an alert to users by SMS using GSM. In this paper, the users are alerted by using the Internet of things (IoT) which is a new concept in clouding, it is a network of physical devices, vehicles, home appliances, and other items embedded with electronics, software, sensors, actuators, and network connectivity which enable these objects to connect and exchange data.

For the communication of mobile and email with the gas sensor, the concept of IOT comes into the picture, is the network of physical devices, vehicles, home appliances and other items embedded with electronics, software, sensors, actuators, and connectivity which enables these objects to connect and exchange data."^{[3][4][5]}

2. Methodology

2.1 C2000 Piccolo MCU

The C2000 Piccolo MCU F28027 is an advanced version of MCU manufactured by Texas instruments As it is suited for advanced closed-loop control applications such as industrial drives and servo motor control; solar inverters and converters; digital power; transportation; and power line communications, here it is employed for

- Observing and checking the exceeding threshold value via a gas sensor which is prefixed. As the threshold values cross, the program is executed and MCU instructs the buzzer* to ring and alert the livings in that vicinity.
- Along with this MCU also sends an email (concept of IOT^{[3][4][5]}) to the concerned about the leakage of gas and a message is dropped on the mobile phone of the needy, these all tasks are initiated and are done under control of MCU.
- MCU also powers the stepper motor to begin rotating.
- LCD, exhaust fan, and relay all begin to come in action in accordance to MCU(as inscribed over the RAM of MCU)

2.2 Wi-Fi Module

- Most important work is served by this component.
- This module connects MCU with our devices and contributes to the overall connection as it is responsible for sending the email and message on mobile.
- It sets up a server by itself and opens the door for one end to connect to the other.

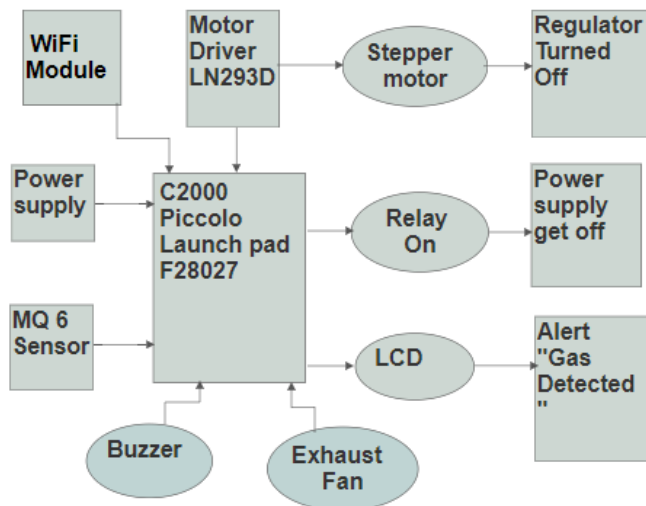

Fig -1: (Block Diagram of the complete system)

2.3 LCD

LCD pops up with a display, says 'Gas detected Alert ON', as shown in the figure3:



Fig -2: (Liquid crystal display; alert the user)

Moreover the code involved in to bringing this display on the screen is also given below:

```
LiquidCrystal lcd (12, 11, 5, 4, 3, 2);
void setup()
{
  lcd.begin (16,2);
}
void loop()
{
```

```
  If()
  {
    lcd.setCursor (0, 1);
    lcd.print ("No LPG Gas Leakage");
  }
  else
    lcd.print ("WELCOME WORLD"); }
```

2.4 Stepper Motor

This motor is employed into accomplishing the unique task of this alert system that is, in the appropriate scenario the MCU instructs the motor to begin rotating by an angle of 90° and turn off the knob of the regulator.

2.5. Exhaust Fan

In case of excess of gas being leaked already the chances of misshapen increases relatively to combat this, an exhaust fan is employed to evacuate the place.

2.6. Buzzer

When the buzzer gets the required voltage, which actually is monitored and instructed by MCU it begins to buzz and alerts the nearby.

2.7. MQ-6 Sensors

This component is significant in the detection of any of the gas compositions like butane, propane, natural gases which are accomplished by SnO₂.

3. Flow Diagram

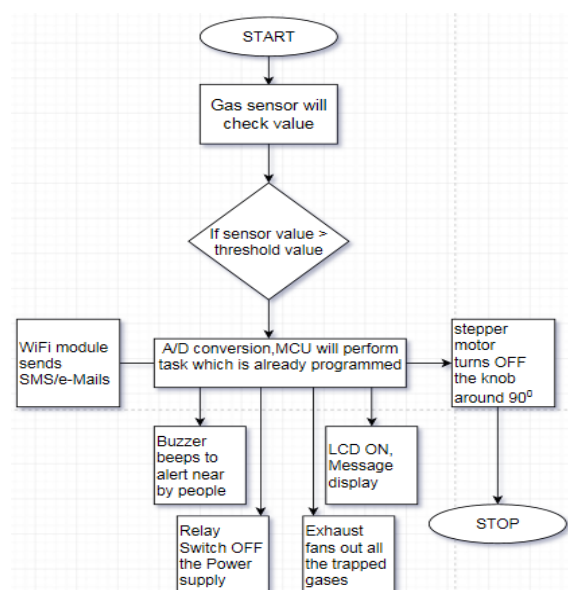

Fig -3: (Flow diagram, explaining the complete working)

4. Advantages

■ As this kit cum system is being developed throughout with a vision of contributing to social welfare and it aims at influencing lives helpfully and positively. Fortunately, to an extent, we have managed to serve our society with the following key helps:

➤ This system, as its 50% profile of work is meant to alert the user, even the dumb can identify the leakage as the LCD(prototype) screen turns ON and begin to flash a message 'Gas detected Alert ON'.

➤ Even the blind or ones away from the site for sight are been able to be informed and accounted by means of the ringing of the buzzer.

➤ In case of absence of any mobile lives in the premises of gas leakage or the presence of any paralyzed or movement disabled handicapped, the feature of mechanical knob OFF switch is of great service.

■ Use of c2000 Piccolo series of microcontroller has implicated many unique and advantageous aspects:

➤ Using an advanced microcontroller has laid a foundation for building of many new technologically advanced systems with better utility in future

➤ This MCUC2000 Piccolo has high efficiency for driving motor and provide sufficient torque as required in the application making it most suitable and advantageous microcontroller

5. Future Scope and Conclusion

Provided with the given features this system can be made more serviceable by adding few more basic small inputs like

➤ Temperature: To monitor the temperature of the cylinder as well as the environment and program the system to act accordingly.

(Note: Piccolo comprise of on-chip temperature sensors and LEDs)

➤ Although this system is benefited by IOT for emailing and messaging this can be made huge by supplementing it with Android and GSM for emailing and messaging.

➤ LED: can also add-up to its indicating credibility by flashing indicating gas leakage.

➤ Sensors: Continuous and productive involvement and the addition of relevant and upcoming new technology-based sensors would affect largely to the credibility of the system.

The research and development would hit new dimensions in case of introduction of any impurity detection sensors of new gas detectable sensors.

➤ Here IOT is limited to emailing and messaging nevertheless an app can be developed featuring many more viable services.

This gas system is successfully able to perform all the stated functions and has shown to be a great tool from a gas safety point of view.

6. Result

The result of this project is determined by using a lighter to collect leaked gas around the gas sensor after sensing procedure if sensor value is greater than the threshold value then micro-controller will perform its programmed tasks:

1. Immediately turn off the regulator knob to stop further leakage
2. Within 2-4sec the relay will cut off the main power supply.
3. Buzzer starts beeping and a message is displayed on LCD to alert the users and nearby people.
4. Wi-Fi module will send SMS/e-mail using the cloud to the users.
5. The exhaust fan will fan out all enclosed gas from the environment. When reset button of MCU pressed the system will get refreshed.

Along with attainment of these proposed features successfully, one of the major factors of cost efficiency or normalization has also been the concern throughout which is also brought in focus during the process of building this system.

Moreover, its highlight or the USB is that it is multiple operational projects and combines many features in all together at one place.

Reference

1. Michael Barr. "Embedded Systems Glossary". Neutrino Technical Library. Retrieved 2007-04-21.
2. Heath, Steve (2003). Embedded systems design. EDN series for design engineers (2 Ed.).Newness. p. 2. ISBN 978-0-7506-5546-0. An embedded system is a microprocessor-based system that is built to control a function or a range of functions.
3. Brown, Eric (13 September 2016). "Who Needs the Internet of Things?". Linux.com. Retrieved 23 October 2016.
4. Brown, Eric (20 September 2016). "21 Open Source Projects for IoT". Linux.com. Retrieved 23 October 2016.

5. "Internet of Things Global Standards Initiative". ITU. Retrieved 26 June 2015
6. Gayathri S Nair, Anandhakrishnan S, Deepesh Nair, Rakesh K, Sampath K, -"IOT Based Smart Gas Monitoring System" e-ISSN: 2278-1676,p-ISSN: 2320-3331, PP 82-87, IOSR Journal of Electrical and Electronics Engineering (IOSR-JEEE).
7. Ashish Shrivastava, Ratnesh Prabhaker, Rajeev Kumar and Rahul Verma, GSM-based gas leakage GSM detection system, www.ijtra.com, International Journal of Technical Research and Applications e-ISSN: 2320-8163, 2013.
8. Prof.M.Amsaveni, A.Anurupa, R.S.Anu Preetha, C.Malarvizhi, M.Gunasekaran, GSM-based LPG leakage detection and controlling system, The International Journal Of Engineering And Science (IJES) ISSN (e): 2319 – 1813 ISSN (p): 2319 – 1805, March 2015.
9. A Review of Microcontroller based LPG Gas Leakage Detector, Vasudev Yadav, Akhilesh Shukla, Sofiya Bandara, Vipin Kumar, Ubais Ansari, Suraj Khanna Journal of VLSI Design and Signal Processing Volume 2 Issue 3.
10. Zhao Yang, Mingliang Liu, Min Shao, Yingjie Ji Research on leakage detection and analysis of leakage Point in the gas pipeline system. In Open Journal of Safety Science and Technology; 2011.
11. S Shyamaladevi, V G Rajaramya, P Rajasekar, P Sebastian Ashok. ARM7 based automated high performance System for LPG refill booking & Leakage detection. 2014.