

# Design, Analysis and Optimization of an Intake Manifold of two cylinder Stationary Diesel Engine

Sourabh Shrikrishna Chinchankar

Mechanical Engineer, Pune, Maharashtra, India

\*\*\*

**Abstract** - Geometrical design of intake manifold is very important aspect for obtaining for the good performance of an I.C. stationary diesel engine under varied load conditions. Unequal velocity distribution of intake air at runner's outlets of intake manifold makes it less efficient. This Paper aims to make this unequal distribution of flow of air in nearly equal manner with increase of velocity of air at outlets without any major modification in design of intake manifold.

Generator engine intake manifold was experimentally tested, to examine the variation of velocity of air flow at outlet of two runners. To modify the intake manifold to increase the volumetric efficiency, first a 3-D model of existing manifold is made in design software CATIA V5R21 and then validation of design model is done by using commercial CFD package ANSYS CFX 16 and engine simulation software GT-ISE 7.4. To achieve the desired improve results two other models of same intake manifold with different design configuration are made in software then examine the result of these two models with original one to compute pressure and velocity losses, flow characteristics and various other parameters.)

**Key Words:** Runner, Plenum, Intake manifold, Secondary Pipe, Volumetric efficiency

## 1. Introduction

It has long been known that an optimized design of the intake manifold is essential for the optimal performance of an IC engine. An intake manifold (IM) is usually made up a plenum, a throttle body connected to the plenum, and runners which connect to the engine cylinders. Because in CI engine, only air is the fluid in Intake Manifold, a designer has a wider choice for selecting the intake manifold geometry than one has for SI engines. The main task of an Intake Manifold is to distribute air between cylinder properly, identical distribution of air to cylinders is vital for an optimized engine. An uneven air distribution leads to non-uniform air flow in the cylinder which results in drop of volumetric efficiency, power loss and increased fuel consumption. One of the designs that help to achieve this goal is using an Intake Manifold with symmetrical geometry. The Intake Manifold geometry has strong influence on the volumetric efficiency in IC engines. During the operation of an IC engine, pressure waves occur because of pressure drop in cylinders in during suction stroke. Depending on amplitude and phase of these pressure waves, filling of cylinders can be affected positively or negatively. The amplitude and phase of these pressure waves depend on

Intake Manifold geometry, Engine speed, Mach number, Mach index and valve timing. The design of an intake manifold can be accomplished in different ways. Due to advancement of computers and CFD software, using 3-D simulation of the flow within intake manifold is growing fast these days. With using this method we can predict, observe and analyze the flow within an intake manifold and evaluate how the Intake Manifold works under steady and unsteady situations.

## 1.1 Objective

The motive of redesigning an Intake Manifold is to increase the overall performance of engine by increasing its volumetric efficiency with proper air flow into the engine cylinder with minimum resistance for every suction stroke during its operation and optimize the various parameters of the intake manifold with the constraints of the brake power and brake specific fuel consumption of the engine.

## 1.2 Scope

Conventional intake manifolds have fixed air flow geometry and static intake manifold. The static intake manifold can only be optimized for only a specific speed and this speed corresponds to maximum torque for a given engine. So it is beneficial to develop a method to vary the intake length to broaden the torque curve. Various designs for variable intake geometry have met with varying degrees of success. But the variable intake geometry does not suit the stationary engines as they run at constant speed. So we have to tune the manifold to a particular speed to obtain the maximum volumetric efficiency for that given speed. The air intake capacity of the engine is increased by variation of intake manifold parameters which results in greater mass flow rate.

## 2. Methodology

The methodology incorporates designing of the main Parameters of the intake manifold along with the analytical calculations associated with it. The Geometry of the existing Intake manifold is analyzed with the help of CAD and CAE tools. After performing Reverse engineering, DOE and DFMEA analysis, an Intake Manifold is redesigned according to serviceability and durability. Computational Fluid Dynamic analysis to obtain necessary flow Pattern in order to obtain frictionless flow with minimum loss of air. Engine simulation on GT Simulation software to obtain to perform Real Time Engine performance in virtual environment. The final

optimized Model is manufactured and installed on Stationary Engine to obtain actual Performance of an Engine.

### 2.1. Design of Intake Manifold

Intake manifold of a Two cylinder Stationary Gen-set Engine is designed on CATIA V5R21 including Plenum Chamber, unner, Primary and Secondary Pipes which are merely welded to form an integrated structure of manifold. The Volumetric efficiency of perticular intake manifold is calculated by considering Mass flow rate of air and Engine Displacement.

**Table 1. Engine Specifications**

Engine Specifications	Values
Engine Bore (mm)	105 mm
Stroke Length (mm)	117 mm
Engine Brake Power (Kw)	19
Compression Ratio	19:1
Constant Engine Speed (rpm)	1500

$$\begin{aligned} \text{Engine Displacement} &= (\text{swept volume / cylinder}) \\ &\quad \times \text{No of cylinder} \\ &= (1013.10) \times 2 \\ &= 2026.2 \text{ cc} \end{aligned}$$

$$\begin{aligned} \text{Volumetric efficiency} &= 60 \times m_i / ((N/2) \times V_d \times \rho_i) \\ &= 60 * 0.025 / (750 * 0.02026 * \\ &\quad 1.169) \\ \eta_v &= 85.79 \% \end{aligned}$$

$V_d$  = Engine displacement,  $\rho_i$ = Air Density

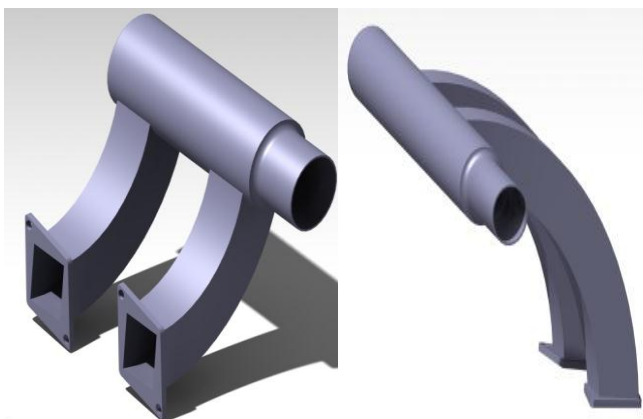

**Fig.1 CAD model of the intake manifold of existing and optimized engine model**

### 3. Intake Manifold Tuning and Optimization

A Design of Experiments (DOE) is a structured, organized method for determining the relationship between independent and dependent variables. A DOE can be set up and run using GT-SUITE to determine the effect of one or more input parameters (factors) on various result quantities (responses). After the DOE has been run, the DOE Post Processor can be used to investigate the results and to perform optimization tasks.

Engine intake manifold Tuning:

Engine Intake manifold can be tuned by using various Methods

1. Using Helmholtz Resonator
2. Using Ohata Ishida model
3. Using Variable Intake valve timings

The Intake Manifold is tuned using variable Valve timing method in order to obtain optimum volumetric efficiency. The other two methods as they are not able to quantify the performance effects and therefore provide no selection criterion for selecting between configurations which have the same natural frequency. The engine speed range over which any relative performance improvement may occur is not obtained and undesirable dips in the torque curve due to manifold gas dynamics cannot be predicted.

#### 3.1 Optimization of Intake Manifold

Induction systems can be tuned to give improved cylinder charging at particular speed and manifolds exploit this phenomenon in enhancing volumetric efficiency. The tuning of an engine is very much affected by length of the primary pipes, diameter of runners in the manifold. The manifolds can be increased and decreased in the intervals of 50 mm over few steps.

Plenum allows the intake system to tune in a number of different modes. By taking Variation of valve timing to achieve maximum advantage of the wave action of the manifold. Modeling of the manifold and variation of the valve timing was independently carried out and the results of each of these sub models to obtain the overall performance of the manifolds. The reason for going for such a complexity is to obtain the best volumetric efficiency from the intake manifold engine combination. The Brent method was adopted during the optimization of these above 5 parameters simultaneously to attain maximum volumetric efficiency for the given stationary engine.

**Table 2. Variation in different geometric parameters of the existing intake manifold**

Geometric Parameter	Alteration
Secondary pipe diameter(Dse)	Decreased by 7 mm
Secondary pipe length(Lsep)	Increased by 25 mm
Plenum diameter(Dplp)	Increased by 6 mm
Plenum length(Lpup)	Increased by 110 mm
Runner length	Increased by 50 mm

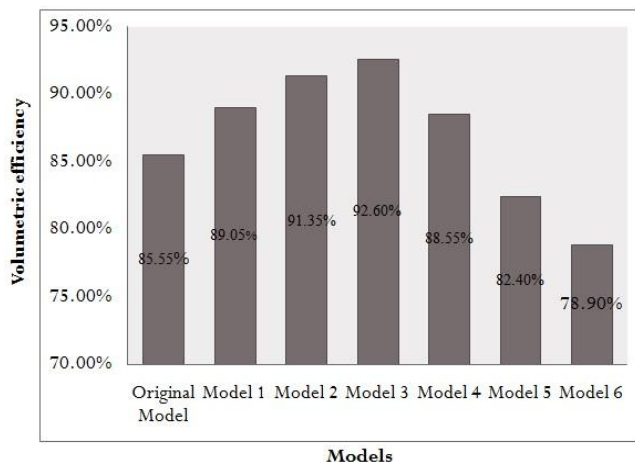

**Fig.2: Comparison of the optimized models with existing model in terms of volumetric efficiency**

**Table 3. Comparison of Optimized model with the existing Parameters**

Parameter	Baseline model	Optimized Model
Volumetric efficiency (%)	85.55	92.60
Mass flow rate of air (kg/hr)	91.6	99.2
Brake power (kW)	19.1	19.2
BSFC (g/kW-hr)	240.2	241.4
Secondary pipe diameter (mm)	58	43
Secondary pipe length (mm)	50	100
Plenum pipe diameter (mm)	61	47
Plenum pipe length (mm)	198	418
Runner length (mm)	228	328

#### 4. Analysis of Intake manifold

In this paper, pressure waves for the intake manifold is simulated using 1D GT POWER software, to study the internal air flow characteristic for the 2-cylinder diesel engine during transient conditions. Based on the 1D simulation results, the intake manifold design is optimized using 3D CFD software under steady state condition. From the software, variation of pressure pulses with various crank angles is obtained for all the three runners at different engine speed conditions and obtaining graph shows that pressure variation is more due to sudden increase in the velocity of incoming air. Therefore intake manifold (IM) geometry near the corners should be made smooth to avoid sudden increase in the pressure waves.

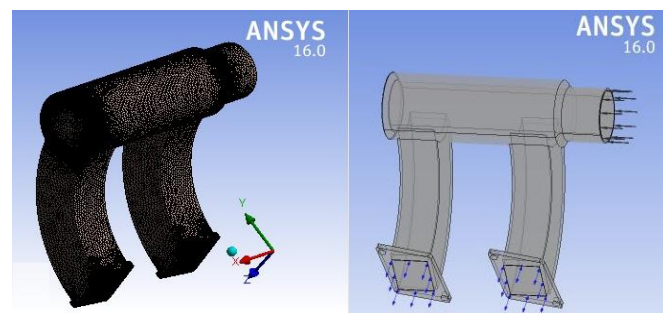

**Fig.3: Mesh Model and Boundary conditions applied on intake manifolds**

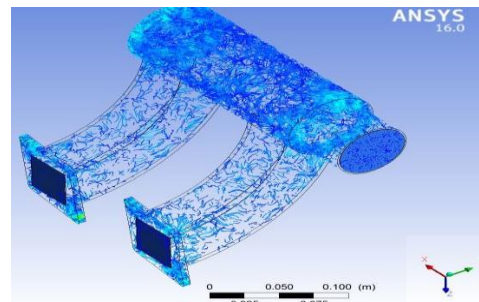

**Fig .4: Flow of air inside intake manifold**

**Table 4 : Boundary Condition for fluid flow of existing Model**

Parameters	Values
Turbulence model	K-ε (enhanced wall treatment)
Inlet boundary condition	Total pressure (ambient)
Outlet boundary condition	Total pressure (vacuum)
Inlet pressure (atm)	1
Outlet pressure (bar)	0.9

**Table 5 : Results obtained from CFD analysis for existing Intake Manifold**

Sr. no	Dse (mm)	Lsep (mm)	Dplp (mm)	Lpup (mm)	Ma Kg/hr	$\eta_v$ (%)
1	57.5	50.2	61	198	43.4	83.72

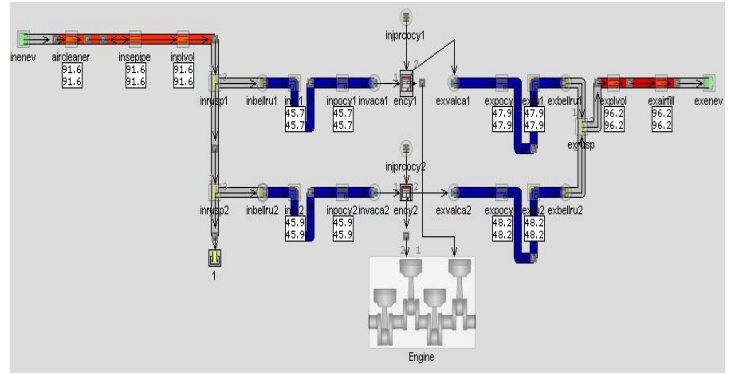

**Fig.7: General layout of Engine model in GT-ISE with Profile Injection**

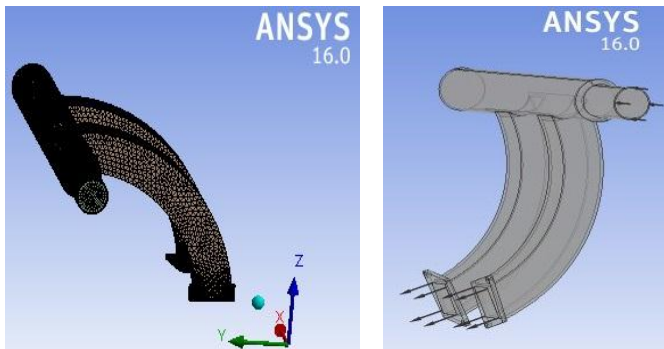

**Fig.5: Mesh Model and Boundary conditions applied on optimized intake manifolds**

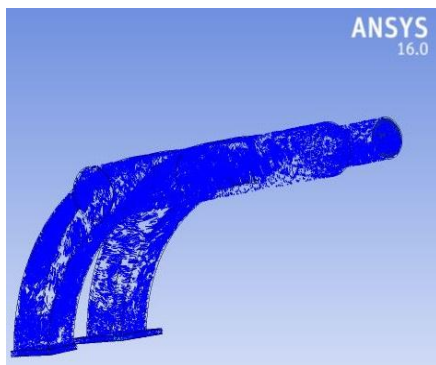

**Fig.6: Uniform Flow of air inside optimized intake manifold**

**Table 6: Results obtained from CFD analysis for optimized Intake Manifold**

Sr. no	Dse (mm)	Lsep (mm)	Dplp (mm)	Lpup (mm)	Ma Kg/hr	$\eta_v$ (%)
1	43.5	100	47	418	48.2	92.1

**4.1 GT 1D Simulation Results**

GT 1D Simulation results describe about the Integrated and Volumetric mass flow rate of air at the end of Suction stroke at BDC Position considering variation in Plenum and runner parameters

**4.1.1 Variation of the Secondary Pipe (Diameter)**

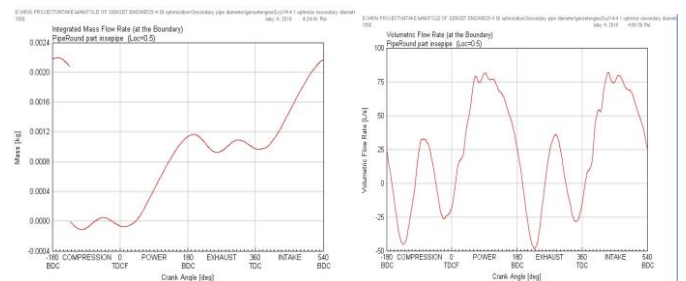

**Fig.8: Integrated and Volumetric mass flow rate of air in the secondary pipe (diameter)**

**4.1.2 Variation of the Secondary Pipe (Length)**

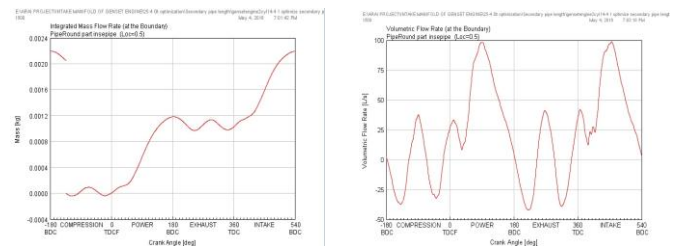

**Fig.9: Integrated and Volumetric mass flow rate of air in the secondary pipe (length)**

**4.1.3 Variation of the Plenum (Diameter)**

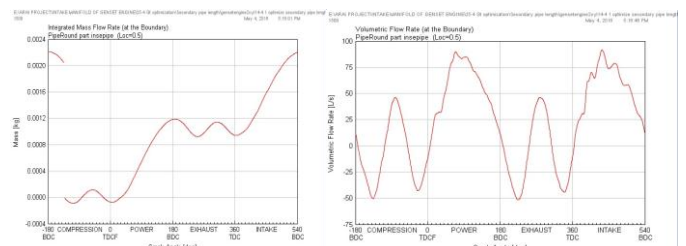

**Fig.10: Integrated and Volumetric mass flow rate of air in the Plenum Pipe**



#### 4.1.4 Variation of the Plenum (Length)

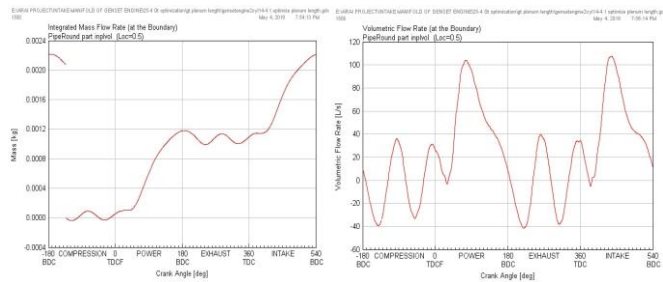

**Fig.11: Integrated and Volumetric mass flow rate of air in the Plenum Pipe**

#### 4.1.5 Variation of the Runner (Length)

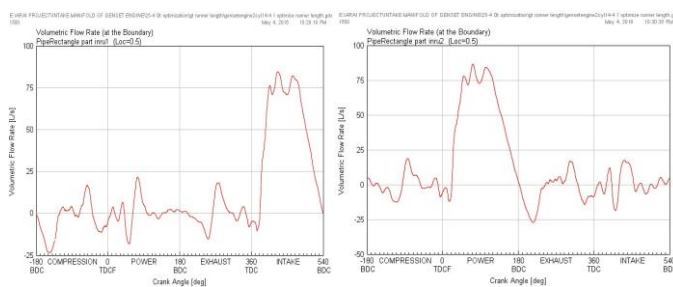

**Fig.12: Volumetric mass flow rate of air in the cylinder 1 and Cylinder 2**

### 3. Results and Conclusions

1. It is observed that volumetric efficiency is increased considerably by altering various above parameters and the value of volumetric efficiency is increased by **7.05%** from the existing model.
2. The intake manifold designed is compact and having minimum frictional resistance and the flow in the .cylinders of the engine is uniform as volumetric efficiency difference between the cylinders is **0.6%**.
3. Intake manifold with volumetric efficiency **92.60 %** is finalized as optimum model after serious analysis of flow patterns and also considering mass flow rate, manufacturability, constraints on the engine and applicability of the same on existing engine.
4. The range for brake power is **18.7 kW to 19.3 kW** and our value for optimized result is **19.2 kW** which is within the limits. The range for brake specific fuel consumption is **240 to 242 g/kW-hr** and our value for optimized result is **241.4 g/kW-hr**.
5. The deviation in the volumetric efficiency of the intake manifold is **0.24%** as per the experimental and GT-ISE simulation model. The permissible deviation of the volumetric efficiency is 3.37% as per the SAE paper **2007-01-3534**.

### REFERENCES

1. DE Winterbone and RJ Pearson, Theory of engine manifold design, 1<sup>st</sup> edition, Professional Engineering Limited, UK 2000, pp. 13- 462.
2. DE Winterbone and RJ Pearson, Design techniques of intake manifold, 1<sup>st</sup> edition, Professional Engineering Limited, UK 2000, pp. 24- 321.
3. John. D. Anderson, Jr, Computational Fluid Dynamics, 2nd edition, McGraw- Hill Inc., Singapore 2009, pp. 25-138.
4. John. B. Heywood, Internal Combustion Engine Fundamentals, McGraw- Hill Inc., Singapore 2009, pp. 350-354.