

DESIGN AND DEVELOPMENT OF VIBRATION ANALYZER USING THE TM4C1233H6PM MCU USING 3-AXIS MEMS ACCELEROMETER ADXL325

Ranjitha R¹, Viswanath K²

¹PG Student, Dept. of Telecommunication Engineering, Siddaganga Institute of Technology, Karnataka, India

²Professor, Dept. of Telecommunication Engineering, Siddaganga Institute of Technology, Karnataka, India

Abstract - In this Paper, a hardware is to be designed & Fabricated which can detect vibration using ADXL325 MEMS Accelerometer, which measures acceleration force in the three Directions x, y, z and measured the acceleration force gives an Analog output, which is input to the analog pins of Microcontroller TM4C1233H6PM through op-amp acting as voltage follower. The value of the processed vibration is transmitted to Personal computer using a high speed USB Stack using Microcontroller.

The results are graphically displayed in Vibration Analyzer PC Software, which is built using Virtual Studio.

Key Words: Vibration, TM4C1233H6PM MCU, ADXL325 MEMS Accelerometer, Voltage Follower, Virtual Studio

1. INTRODUCTION

Mechanical Vibration is a Waving motion of bodies from its rest point, where it occurs due to the presence of restraint. Vibrations are all over: Vocal-cords and eardrums of Human being, Residual imbalance of vehicles, Musical instruments, Turbines, pumps of rotating machinery and so on. Excessive Vibration can have detrimental effects like Noise, loosening of fasteners, Tool chatter and so on. In simple way, it is transferability from Potential energy to Kinetic energy and vice regal in alternating fashion. In Presence of mechanism for dissipating energy, oscillation diminishes gradually. In general Inertia, Elasticity and Energy dissipation are the three majorly Essential component of Vibratory motion [1].

Industrial applications such as Motor Pumps, Conveyor belts, Compressor machines, mechanical engines, Electric Fans, High Rollers and Turbines have rotational elements at particular frequency in which it will Spawn vibration. The performance or quality of machines indicated by amplitude of Vibration [2]. If there is increase in amplitude, it direct result in the failing rotational elements.

Several Faults in Rotating machinery are: Rolling element bearings, Electrical related problems, Resonance, Flow-related problems, Mechanical looseness, Rotor rubs, Worn rollers, Parallel Misalignment, Angular Misalignment ,Machine out of Balance, Shafts Bent, Gear mesh disturbances, Disturbances of Blade Pass, Disturbances of Vane pass, Cavitation and Recirculation Critical Speeds of Machines[3]. To detect these faults, design hardware for 12 channel accelerometer with sampling rate of 48KS per Second Per channel.

2. HARDWARE DESIGN OF VIBRATION ACCELERATION MONITORING AND ANALYSIS SYSTEM

The main objective is to design hardware for Vibration Analyzer which Analyze vibration caused by moving mechanical parts. Using a Tiva™ C Series ARM Cortex-M4 as CPU with Two 12-bit ADC modules. This is required to support four tri-axial analog accelerometer.

Vibration Analyzer is a device which is used to analyze vibration caused by moving mechanical parts. Using a Tiva™ C Series ARM Cortex-M4 as CPU with Two 12-bit ADC modules. The device totally supports four tri-axial (total 12 channels) analog accelerometers and has got a sampling rate of 48 KS per second per channel. The user interface is software that runs on a PC that plots the vibration of each channel.

2.1. SENSOR: ADXL325

The Sensor ADXL325 is the Variable Capacitive MEMS accelerometer which is used to measure physical parameter such as acceleration of $\pm 5g$ i.e. ($5 \times 9.8 \text{ m/s}^2 = \pm 49 \text{ m/s}^2$) is the value which is the measurement range of Accelerometer. This measures frequency down to 0Hz (static or DC acceleration)[4]. Using the capacitors CX, CY and CZ at the XOUT, YOUT and ZOUT pins user selects the bandwidth of the accelerometer with a range of 0.5Hz to 1600Hz for X and Y axes and a range of 0.5Hz to 550Hz for the Z axis.

Employing CX, CY and CZ Capacitor at the output of XOUT, YOUT and ZOUT pins clients selects the specific bandwidth of the accelerometer with a limit of 0.5Hz to 1600Hz for X and Y axes and a limit of 0.5Hz to 550Hz for the Z axis[5][6].

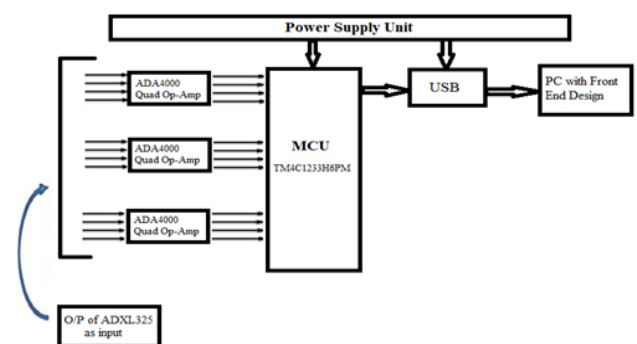

Fig -1: MEMS Vibration Analyzer Version 1.0

Features

- 3-axis (X,Y and Z) analysis Accelerometer
- 16-lead frame chip scale package of dimension 4 mm × 4 mm × 1.45 mm
- Average deep power of 350µA
- Exclusive operation supply between 1.8 V to 3.6 V
- Shock durability of 10,000 g
- Distinctive temperature stability
- Regulation of Bandwidth with an individual capacitor per axis
- Restriction of Hazardous Substances Directive lead-free compliant

2.2. ADA 4000 Quad Op-amp:

The ADA4000 are JFET input Quad ideal Op-amp highlighting precision having lesser input bias current, Broad Bandwidth, Rapid slew rate, High input impedance and quick settling time. It is an ideal Quad Op-amp for active analog-to-digital inputs and buffering digital-to-analog converter outputs. The input common-mode voltage contains the positive power supply, which makes the part a desirable choice for eminent-side signal conditioning.

ADA4000 Quad Op-amp incorporates the applications like amplification of automatic test equipment, integrator Circuits, Utility Functions such as power supply Control, Monitoring Function, Buffering and so on[7].

2.3. TM4C1233H6PM MICROCONTROLLER

The High operation and extreme integration Tiva™ C Series (ARM Cortex-M4) microcontroller which is located for cost-apperceptive applications necessitating significant processing of the control system and connectivity capabilities[8].

Features:

- Processor core is ARM Cortex-M4F
- Executional operation is of 80-MHz
- Single-cycle Flash memory of 256 KB
- single-cycle SRAM of 32 KB
- USB 2.0 Device
- Two 12-bit ADC modules, which divided 12 input channels with Maximal sample rate of one million samples per second [9].

MCU USB FEATURES: It is a Bidirectional data pin, where it acts as both Input and Output with USB2.0 full speed. It has 4KB dedicated endpoint memory. For efficient transfer uses Micro Direct Memory Access Controller (DMA).

MCU ADC FEATURES: The peripheral where the conversion of a continuous analog voltage to a discrete digital number with two identical converter modules which divided 12 input channels with 12 bit Precision ADC of Maximal sample rate of one million samples per second.

3. ACCELEROMETER ACCELERATION CALCULATION:

An accelerometer Resolution is usually given for systems that integrate an analog to digital converter. Resolution will as usually be described as bits which can then be relate to calculate the resolution in acceleration units [10]. ±5g i.e. (5*9 m/s²=±49m/s²) is the value which is the measurement range of Accelerometer. Concede an accelerometer system has 12-bit resolution; this means

For 3.3 V, 2¹²=4096 counts

3.3 V → 4096 counts

1.65V → 2048 counts

$$\text{Calibration Factor (CF)} = \text{Counts/Ref.Voltage} = 2048/1.65 = 1241.21$$

For Example: 3000counts

i. 3000/CF = 2.4v

ii. Ref.voltage:1.65
2.4- 1.65=0.766 v

iii. Given Sensitivity=174mv/g

$$0.766/\text{sensitivity} (174\text{mv/g}) = 4.4\text{g}$$

4. INSTRUMENTATION SYSTEM

The instrument panel shown in Fig.2 can be fastened under experiment. In Fig.2 each of the elementary unit of the instrumentation system can clearly be distinguished (see in Fig 1).

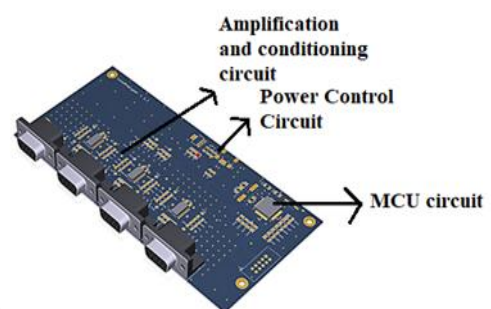

Fig 2: Instrumentation System

5. FIRMWARE DEVELOPMENT FOR MEMS VIBRATION ANALYZER

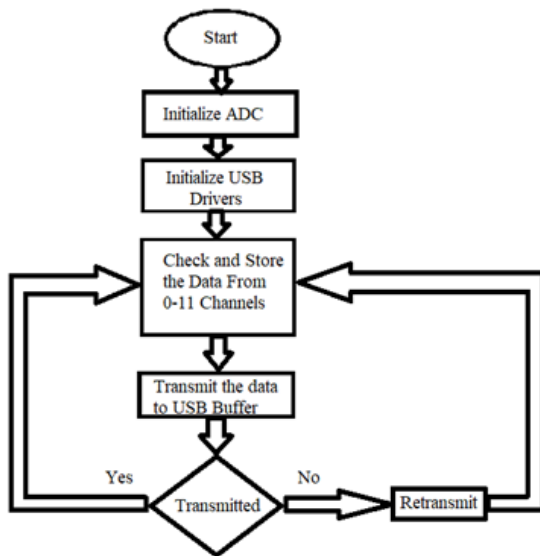

Fig3: Flow Chart of the Firmware Code

Keil's μ Vision IDE is a set of Software tools which stipulate a Powerful, adaptable and easily understandable environment for industrialized embedded apps. It include the components need to design, debug and assemble of C source files and compound simulation for microcontrollers TM4C1233H6PM and relative peripherals. The RTX RTOS Kernel assistance to do complex and time-censorious software. The Flow Chart of Firmware code of MEMS Vibration Analyzer is shown in Fig.3.

6. RESULTS AND THEIR ANALYSIS

The results are graphically displayed in Vibration Analyzer PC Software, which is built using Virtual Studio presented in Fig.4-9. In Fig.4-6 the change in vibration in terms of acceleration been shown, which is received from the accelerometer's X-Y-Z axes respectively. The graphs in Fig.7-9 show the Vibration acceleration Spectrum for each axis (X, Y AND Z).

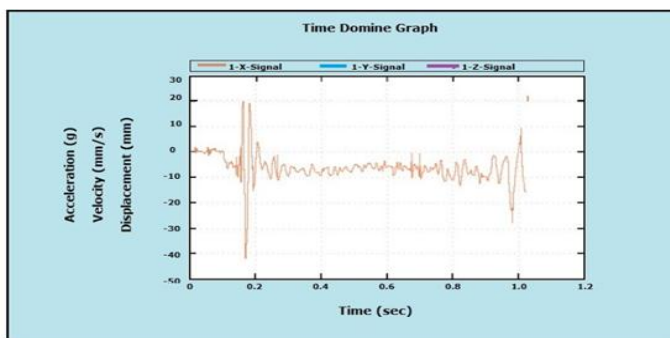

Fig 4: Change in vibration acceleration of the X-axis

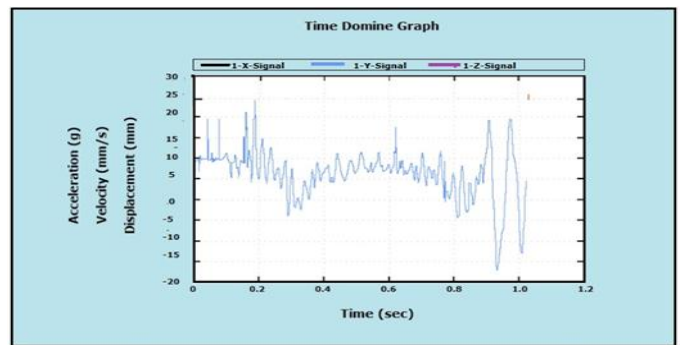

Fig 5: Change in vibration acceleration of the Y-axis

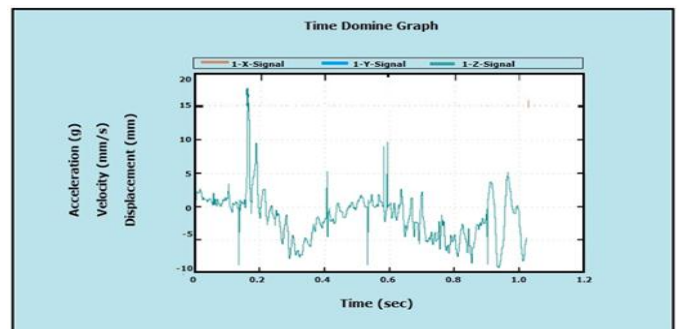

Fig 6: Change in vibration acceleration of the Z-axis

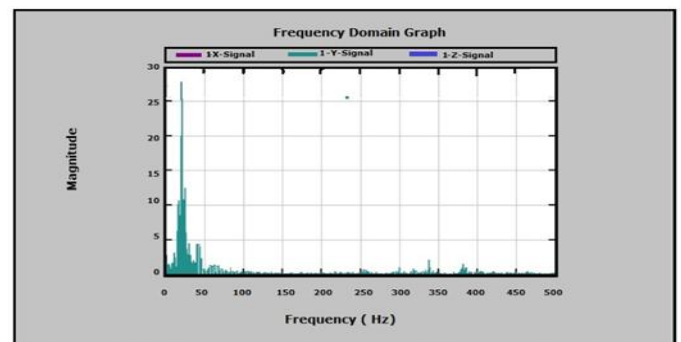

Fig 7: Spectrum graph of the vibration acceleration on the X-axis

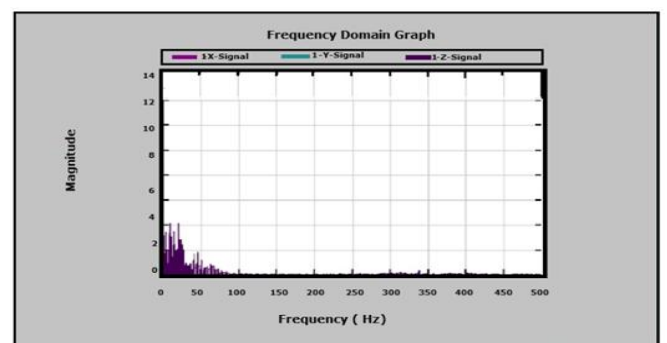

Fig 8: Spectrum graph of the vibration acceleration on the Y-axis

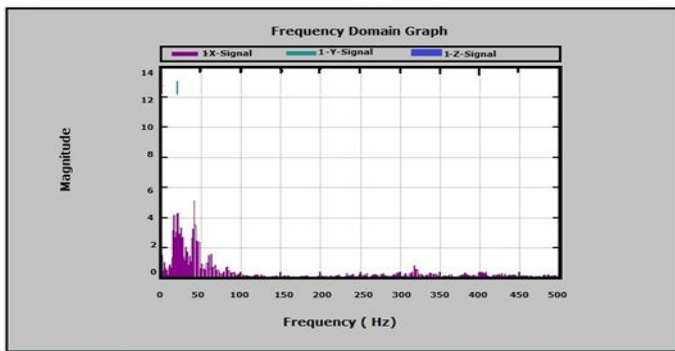

Fig 9: Spectrum graph of the vibration acceleration on the Z-axis

7. CONCLUSION

The Spectrum analyzer of vibration accelerations using the Microcontroller TM4C1233H6PM using 3-axis accelerometer ADXL325 has been developed. The System allows us to perform vibration signal analysis in the time and frequency domains and can operate in real-time mode. The user interface is software that runs on a PC that plots the vibration of each channel and graph visualization of the data has been developed.

REFERENCES

- 1) Saleem Ansari and Rauf Baig "A PC-Based Vibration Analyzer for Condition Monitoring of Process Machinery" IEEE TRANSACTIONS ON INSTRUMENTATION AND MEASUREMENT, VOL. 47, NO. 2, APRIL 1998.
- 2) Giovanni Betta, Consolatina Liguori, Alfredo Paolillo and Antonio Pietrosanto "A IMP-based FFT-Analyzer for the Fault Diagnosis of Rotating Machine Based on Vibration Analysis," IEEE Instrumentation and Measurement Technology Conference Budapest, Hungary, May 21-23, 2001.
- 3) Luis Miguel Contreras-Medina, Rene de Jesus Romero-Troncoso "FPGA-Based Multiple-Channel Vibration Analyzer for Industrial Applications in Induction Motor Failure Detection" IEEE TRANSACTIONS ON INSTRUMENTATION AND MEASUREMENT, VOL. 59, NO. 1, JANUARY 2010.
- 4) L.A. Rocha, E. Cretu', G. de Graaf and R.F. Wolffenbuttel "Mechanical Spectrum Analyzer in Silicon using Micromachined Accelerometers with Time-Varying Electrostatic Feedback" IMTC 2003 ~ Instrumentation and Measurement Technology Conference Vail, CO, USA. 20-22 May 2003.
- 5) Marek Iwaniec, Kostyantyn Kolesnyk, Andriy Holovatyy, Vasyl Teslyuk, Mykhaylo Lobur, Marta Mashevska "Development of Vibration Spectrum Analyzer Using the

Raspberry Pi Microcomputer and 3-Axis Digital MEMS Accelerometer ADXL345" 978-1-5386-4001-2/17/\$31.00 ©2017 IEEE

- 6) Datasheet of ADXL325:
<http://www.alldatasheet.com/view.jsp?Searchword=Adxl325>
- 7) Datasheet of ADA4000:
<http://www.alldatasheet.com/view.jsp?Searchword=ADA4000>
- 8) He Qing, Du Dongmei "Double-channel Vibration Analyzer Based on C8051F" Proceedings of the 27th Chinese Control Conference July 16-18, 2008, Kunming, Yunnan, China
- 9) DS-TM4C1233H6PM-15842.2741SPMS351E "TEXAS INSTRUMENTS-PRODUCTION DATA"
- 10) Khurram Shahzad, Bengt Oelmann "An FPGA-based high-performance wireless vibration analyzer" 978-1-4799-1647-4/13/\$31.00 ©2013 IEEE