

ELECTROMAGNETIC EMISSION AWARE SCHEDULING AND REDUCTION USING OFDM WIRELESS SYSTEM

P.S.NIVETHA¹, V.RAJAVEE², V.VANITHA³

^{1,2}Department of Electronics and Communication Engineering, Jeppiaar SRR Engineering College, Chennai, Tamil Nadu, India

³Assistant professor of Electronics and Communication Engineering, Jeppiaar SRR Engineering College, Chennai, Tamil Nadu, India

Abstract - The increasing demand for Data and multimedia services, and the nature of current generation of mobile communicating devices have resulted in ever increasing number of users. The electromagnetic emission from the systems is increasing the health issues. In order to address this concern, we propose Welch's method with better power and subcarrier allocation using OFDM wireless systems. This highly reduces the EM emission at high level. As a result, this approach has reduced the complexity of the emission towards the users. Our scheme reduces the EM emission around 75%. To minimize the effect of exposure to users use of hands-free, limiting the usage of mobile phones.

Keywords: OFDM wireless system, Welch's method, power allocation and sub carrier allocation.

1. INTRODUCTION

Nowadays, there has been a tremendous evolution in mobile communication over the past few decades. The development of 5th generation of mobile communication devices which is used to connect more devices and access point. The EM emission and serious concerns attached to them would also increase. There is a strong case for developing reduction of EM emission to prevent health issues the guidelines and limits on exposure to EM emission from mobile communication systems have monitored the emission.

Consequently the European environmental agencies have recommended precautionary approaches towards emission. Researchers and equipment manufactures have focused on limits of emission. This approach relies on the ability of the network to predict the CSI of all the users in the network for a given transmission window. We obtain the optimal bit allocation (and subsequently, power allocation) of each user by using a low complexity rate-based water-filling. The network then iteratively optimizes the system until the total EM emission of the system converges. Simulation results demonstrate that with the use of coordination, our proposed scheme is able to reduce EM emission by over 75% when compared to a classic no frequency reuse scheme (no intercell interference) while also significantly outperforming the EM scheme.

The major disadvantage can be rectified with the improved accuracy in power density estimation, and in frequency domain with reduced power loss [1]

The loss in power is directly involves in increasing the amount of EM emission towards the users. That can be properly modified with accuracy in them. which intend to increase the number of user^[2]

2. METHODOLOGY

Methodology which discuss about that detailed description of the process which have been done. Throughout the progress of the requirements and their needs that to solved can be detailed explained below.

A. Sub Carrier Allocation

Subcarrier allocates bits to each carrier signal, users and uses in different sectors can share the same subcarrier. This results in intercell interference that degrades the system performance consisting of one user from each sector are formed based on power. The user grouping is done in such a way that the users that generate the least interference to neighboring sectors are grouped together and then the users in each group are allocated the same set of subcarriers. After user grouping, we consider max-signal to interference ratio (SIR), equal subcarrier allocation for each user in each sector to minimize the EM emission.

The users of different sectors uses subcarrier for the communication purposes. The grouping is done such a way that the users can generate the least interferences to the neighbouring sectors. In each group a bit is allocated for each subcarrier. After these grouping the interference and the noise is highly reduced. Max- signal to interference ratio, equal subcarrier allocation for each user in a sector minimizes the emission.

B. Power Allocation

It includes first power allocation (PA1), second power allocation (PA2). In (PA1) each sector minimizes the EM emission inter relatively optimizing the transmit power of its users. In (PA2) uses average channel gains of users of different sectors to obtain approximate power. Therefore, in the existing system only 70% of emission is controlled towards the users.

C. Welch's Method

It is an improvement on the standard periodogram spectrum estimating method and on Bartlett's method in that it reduces

noise in the estimated power spectra in exchange for reducing the frequency resolution. It is an improvement on the standard periodogram spectrum estimating method and on Bartlett's method in that it reduces noise in the estimated power spectra in exchange for reducing the frequency resolution. The Welch method is based on Bartlett's method and differs in two ways :

1. If $D=M/2$
2. If $D=0$, This is the same situation as in the Bartlett's method.

The overlapping segments are in then windowed; after the data is split up into overlapping segments, the individual L data segments have a window applied to them (in the time domain). Most window functions afford more influence to the data at the center of the set than to data at the edges, which represents a loss of information. To mitigate that loss, the individual data sets are commonly overlapped in time (as in the above step).The windowing of the segments is what makes the Welch method a "modified" periodogram.

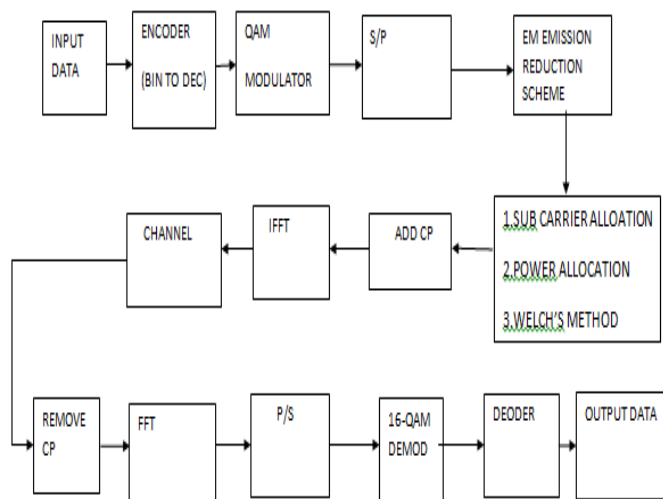

Fig 2.1. BLOCK DIAGRAM OF OFDM WIRELESS SYSTEM

In this we give input data as bit for the transmission of information and encode the signal for the purpose of reduction of noise has been done. QAM (quadrature amplitude modulation used for the purpose of multiple output and further more signal is modified in series to parallel process to which they are arranged in parallel manner, add cp (cyclic prefix) used for the purpose of interval between each signal without interference through channel and to remove cp for maintaining samples of signals at output. Decode is done in the process at the receiver side to get multiple bit.

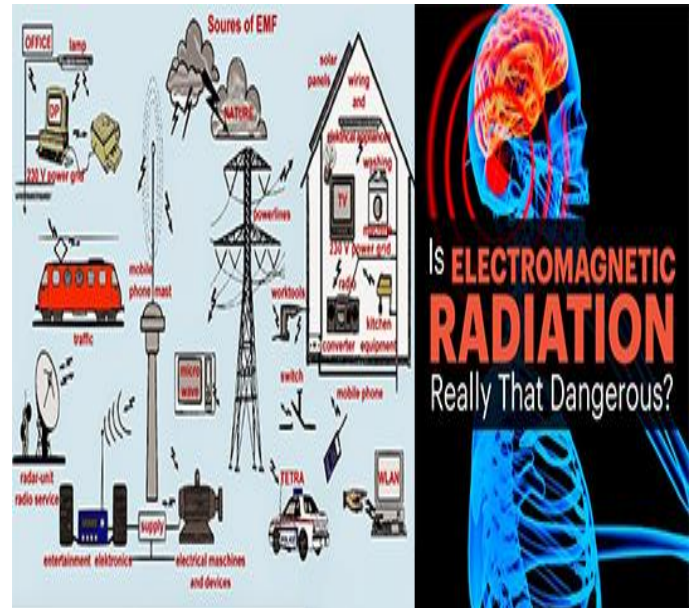

Fig.2.2. REAL TIME SCENARIO OF EM EMISSION

The real time scenario of the radiation emitted towards users. Whereas, nowadays the current generation highly using the mobile communicating devices for the purpose of transmission of Data and multimedia services.

4. RESULTS & DISCUSSIONS

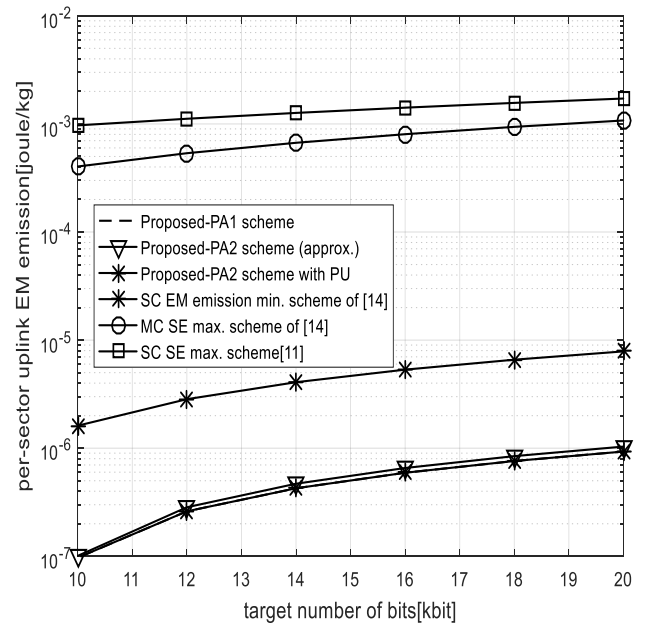

Fig4.1. Water Filling method in existing System [1]

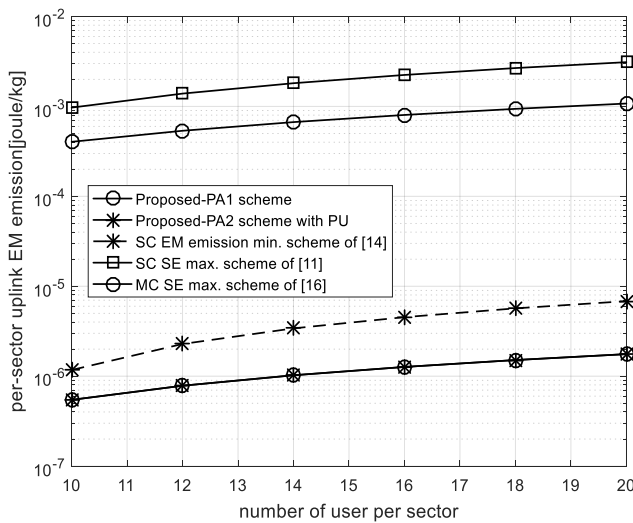

Fig4.2. Scheduler algorithm in existing system [2]

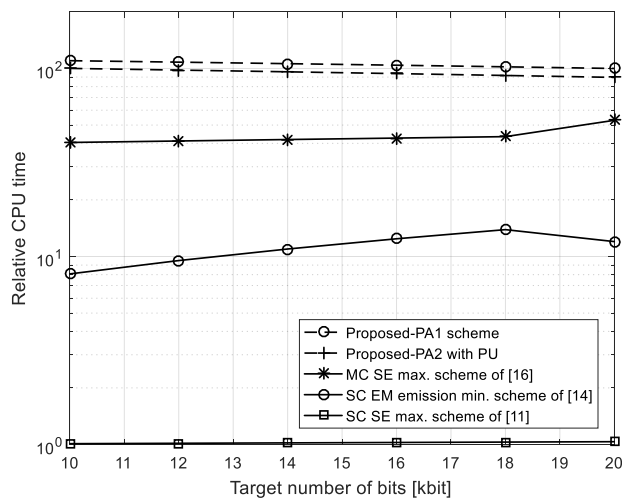

Fig4.3. Subcarrier & Power allocation in existing system [3]

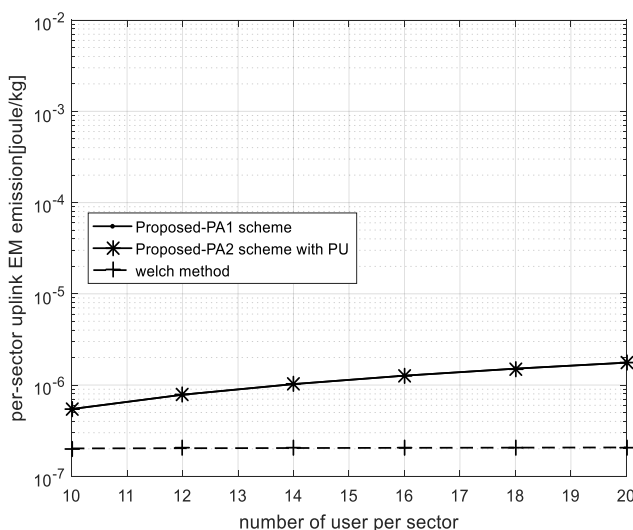

Fig4.4 Proposed Welch's method

COMPARISION BETWEENA EXISTING AND PROPOSED SYSTEM

METHODS		ANALYSIS
WATER METHOD	FILLING	REDUCTION OF EM EMISSION IN TIME DOMAIN WITH LESS ACCURACY
SCHEDULAR ALGORITHM		HIGH ENERGY EFFICIENCY, HIGH NO. OF USERS
SUB CARRIER & POWER ALLOCATION		REDUCTION UP TO 70% OF EM EMISSION
WELCH'S METHOD		REDUCTION UP TO 75% OF EM EMISSION

Table 4.1.

This reduces the EM emission up to 75% of the EM emission by using Welch's method with high reduction of power loss and measurement of accuracy of power transmitted in terms of the frequency domain.

6. CONCLUSION

In this paper, we have proposed a coordinated scheme for minimizing EM emission in the OFDM wireless system. Our proposed EM emission reduction scheme is based on the user's use this information for user grouping and subcarrier allocation and power allocation Simulation results show that our proposed scheme reduces EM emission up to 75% when compared to the existing system scheme respectively. More users without noise and interference .To improve the power efficiency Improve the spectral efficiency. To avoid inter carrier interference.

REFERENCES

[1] International Agency for Research on Cancer (IARC), "IARC Classifies Radiofrequency Electromagnetic Fields as Possibly Carcinogenic to Humans," Press Release No. 208, May 2011.

[2] M. Tesanovic et al., "The LEXNET project. Wireless networks and emf: Paving the way for low-emf networks," IEEE Vehicular Technology Magazine, vol. 6, no. 2, Jun. 2014.

[3] M. Moretti and A. Todini, "A resource allocator for the uplink of multicell OFDMA systems," IEEE Trans. Wireless Commun., vol. 6, no. 8, pp. 2807-2812, Aug. 2016.

[4] M. Al-Imari, P. Xiao, M. A. Imran, and R. Tafazolli, "Low complexity subcarrier and power allocation algorithm for uplink OFDMA systems," EURASIP Journal on Wireless Communications and Networking, vol. 98, no. 1, 2013.

[5] S. Buzzi, G. Colavolpe, D. Saturnino, and A. Zappone, "Potential games for energy-efficient power control and

subcarrier allocation in uplink multicell OFDMA systems,” Selected Topics in Signal Processing, IEEE Journal of, vol. 6, no. 2, pp. 89–103, Apr. 2012.

[6] G. Miao, N. Himayat, G. Y. Li, and S. Talwar, “Low-complexity energy-efficient scheduling for uplink OFDMA,” IEEE Transactions on Commun., vol. 60, no. 1, pp. 112–120, Jan. 2012.

[7] Y. A. Sambo, F. H´eliot, and M. A. Imran, “A user scheduling scheme for reducing electromagnetic (EM) emission in the uplink of mobile communication systems,” in Proc. Green Communications (Online Greencomm), 2014 IEEE Online Conference on, Online, Nov. 2014, pp. 1–5.

[8] Y. A. Sambo, M. Al-Imari, F. H´eliot, and M. A. Imran, “Electromagnetic Emission-aware Resource Allocation for the Uplink of OFDM Wireless Communication Systems,” in Proc. 12th International Symposium on Wireless Communication Systems, Brussels, Aug. 2015, pp. 441–445.

[9] Y. A. Sambo, F. H´eliot, and M. A. Imran, “A Survey and Tutorial of Electromagnetic Radiation and Reduction in Mobile Communication Systems,” Communications Surveys Tutorials, IEEE, vol. 17, no. 2, pp. 790–802, 2015.