

ANALYSIS OF RC DECK SLAB BRIDGE FOR VARYING SPAN

Kapil Kushwah¹, Anshuman Nimade², Mahesh Patidar³, Vikas joshi⁴

^{1,2,3,4} Assistant Professor, CED, Swami Vivekanand college of Engineering, M.P., India

Abstract - The bridge is a structure imparting passage over an impediment without remaining the way under. The desired passage may be for a road, a railway, pedestrians, a canal or a pipeline. T-beam bridge decks are one of the predominant sorts of forged-in vicinity concrete decks and consist of main girders, cross girders which imparts lateral tension to the deck slab and deck slab which runs among T-beams constantly. Bridges are exceedingly investment systems and vital landmarks in any country. Besides being crucial links in transportation device. strength, protection and economy are the Three key capabilities that cannot be left out before the finalization of kinds of bridges. While Deciding the forms of bridge, spans and other parameters are to be studied cautiously to fulfil Out the need of suitability to site situations. the analysis of a three span two lane T-beam bridge is carried out by varying the span of 10m, 15m, 18m, and number of longitudinal & cross girders using software Staad Pro v8i. In order to obtain maximum bending moment and shear force in girder, maximum Stresses in slab and maximum reaction and moment at the support, the bridge models are subjected to the IRC class AA Tracked loading system and concluded that with the increase in shear force, bending moment and deflection in the girder and variation of stresses in slab.

Key Words: Deck slab, Class AA Loading, Staad pro V8i, Stresses on Slab, Shear force and Moment on Girder etc.

1. INTRODUCTION

The bridge is a structure imparting passage over an impediment without remaining the way under. The desired passage may be for a road, a railway, pedestrians, a canal or a pipeline. T-beam bridge decks are one of the predominant sorts of forged-in vicinity concrete decks and consist of main girders, cross girders which imparts lateral tension to the deck slab and deck slab which runs among T-beams constantly. Bridges are exceedingly investment systems and vital landmarks in any country. Besides being crucial links in transportation device. strength, protection and economy are the Three key capabilities that cannot be left out before the finalization of kinds of bridges. While Deciding the forms of bridge, spans and other parameters are to be studied cautiously to fulfil Out the need of suitability to site situations. A bridge must be strong sufficient to assist its own weight as well as the burden of the human beings and vehicle that use it. the shape additionally must face up to diverse natural occurrences, together with earthquakes, robust winds, and modifications in temperature. most bridges have a concrete, steel, or timber framework and an asphalt or concrete roadway on which people and automobiles travel. the T-beam bridge is via far the

maximum generally adopted kind in the span range of 10 to 25 m. the shape is so named due to the fact the principle longitudinal girders are designed as T-beams indispensable with a part of the deck slab, which is solid monolithically with the girders. truly supported T-beam span of over 30 m are uncommon because the lifeless load then turns into too heavy.

1.1 OBJECTIVE OF THE WORK

In this paper a comparative study on the behavior of simply supported RC T-beam Bridge with respect to span moments under standard IRC i.e. AA Class loading. The study is based on the analytical modeling of RC T-beam Bridges by Staad Pro V8i for different spans and calculate the maximum Shear force, bending moment, deflection in girder and maximum stresses in deck slab.

1.2 PARAMETRIC STUDY

A simply supported, three spans, two lanes RCC slab bridge deck is considered. The span is varied from 10m, 15m and 18m and depth of the slab 200mm for all spans. The bridge deck is analyzed for Dead load as well as one class of live load i.e. IRC ClassAA tracked loading. Comparison of critical structural response parameter

No	Span(m)	Width(m)	Aspect ratio (Span/Width)
1	10	10	1
2	15	10	1.5
3	18	10	1.8

2. METHOD OF ANALYSIS

- Analysis is done for IRC Class AA tracked vehicle loading.
- Analysis of T-BEAM Bridge is carried out by using Staad Pro V8i Software for different spans.

Description Bridge	
Bridge type	T-Beam Deck Slab Bridge
Span	10m,15m and 18m
Lane of Bridge	Two lanes
Carriageway Width	7.5m
No. of longitudinal Girder	6
No. Cross girder	4

Thickness of girder	500mm
Depth of girder	500mm
slab thickness	200mm
Live load	AA Class Tracked Vehicle
Spacing of longitudinal girder	2m c/c

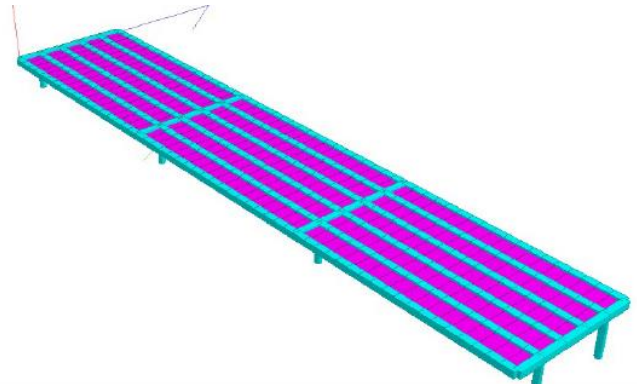

Figure 4 3D Rendering View of 18m Span Deck Slab

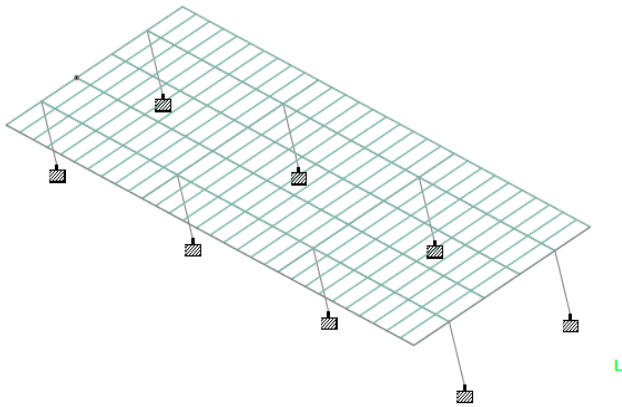

Figure 1 perspective View of 10m Span Deck Slab

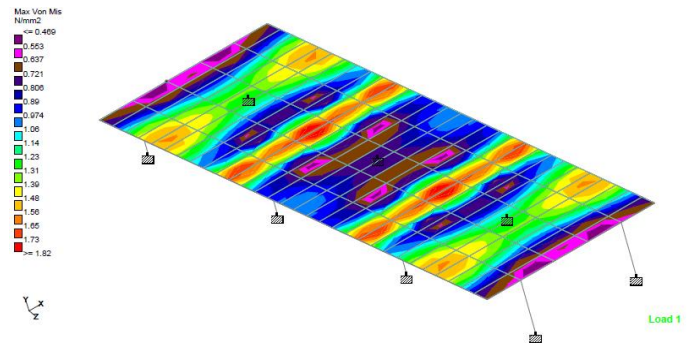

Figure 5 3D Rendering View of 15m Span Deck Slab

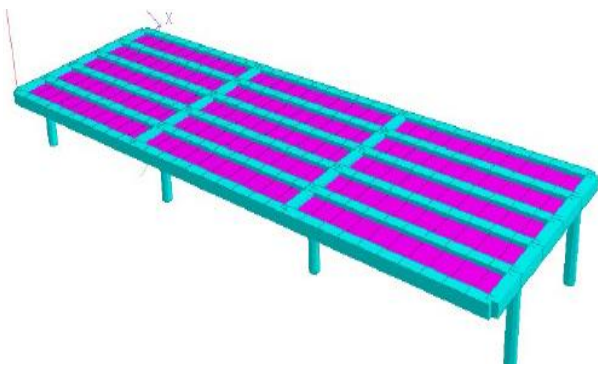
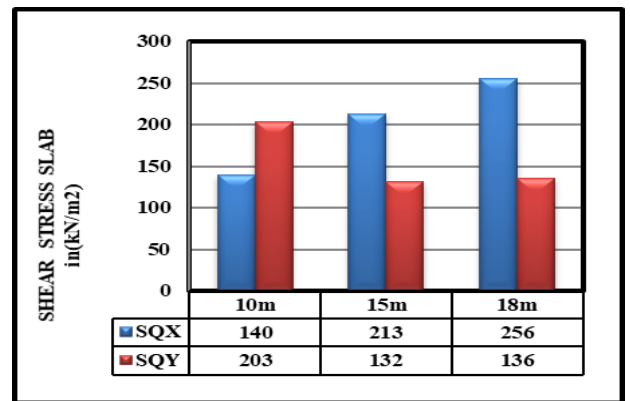

Figure 2 3D Rendering View of 10m Span Deck Slab



Graph 1 Span Vs Center Shear Stresses on Slab

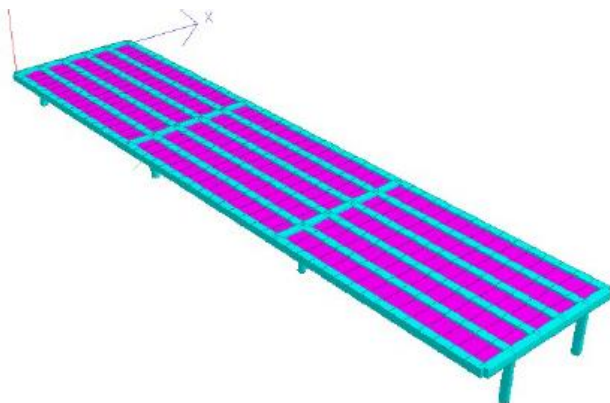
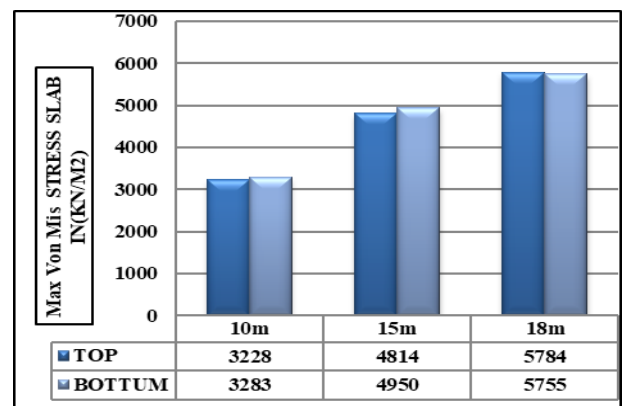
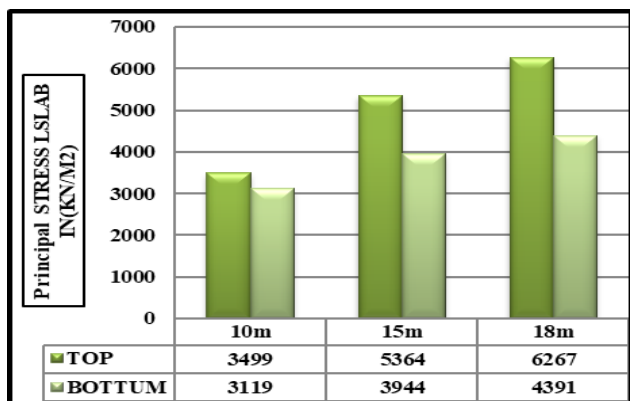

Figure 3 3D Rendering View of 15m Span Deck Slab



Graph 2 Span Vs Max Von Mis Stresses on Slab



Graph 3 Span Vs Principal Shear Stresses on Slab

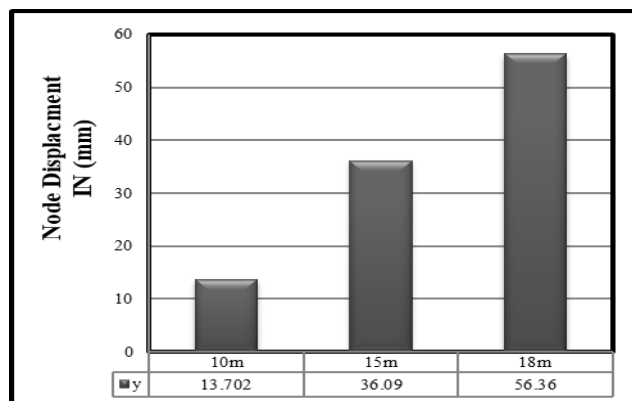

Graph 8 Span Vs Maximum vertical downward node displacement in Longitudinal Girder

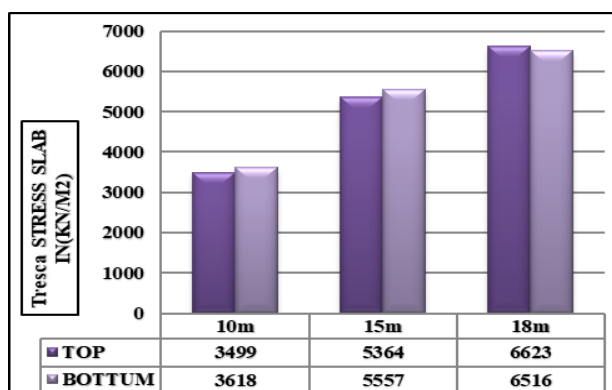

Graph 4 Span Vs Principal Stresses on Slab

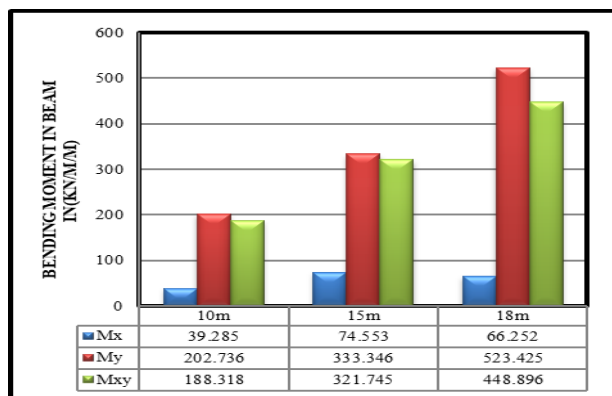

Graph 6 Span Vs Bending Moment on Beam

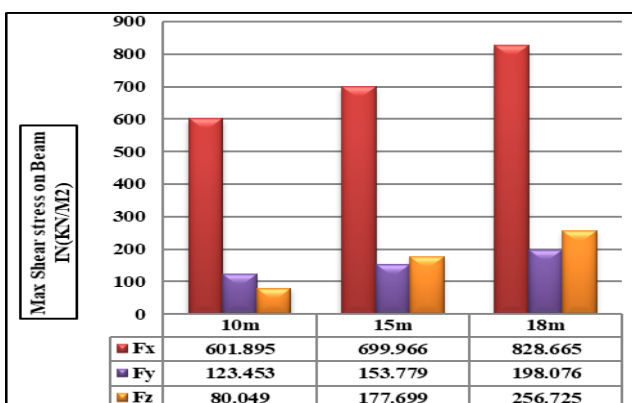

3. CONCLUSION

- Center shear stresses in X direction i.e. SQX in deck slab increases 52% & 83% in 15m & 18m Span Bridge respectively when it compares with 10m span bridge.
- Center shear stresses in Y direction i.e. SQY in deck slab decreases 35% & 33% in 15m & 18m Span Bridge respectively when it compares with 10m span bridge.
- Its concluded that the center shear stresses in X direction i.e. SQX in deck slab more increases with increasing span length and stresses in Y direction i.e. SQY decreases with increasing span length.
- The Von Mis top stresses in deck slab increases 49% & 79% in 15m & 18m Span Bridge respectively when it compares with 10m span bridge.
- The Von Mis Bottom stresses in deck slab increases 51% & 75% in 15m & 18m Span Bridge respectively when it compares with 10m span bridge.
- Its concluded that the Von Mis top and bottom stresses in deck slab more increases with increasing span length.
- The Principal top stresses in deck slab increases 53% & 79% in 15m & 18m Span Bridge respectively when it compares with 10m span bridge.
- The Principal Bottom stresses in deck slab increases 26% & 41% in 15m & 18m Span Bridge respectively when it compares with 10m span bridge.
- Its concluded that the Principal top and bottom stresses in deck slab more increases with increasing span length.

10. The Tresca top stresses in deck slab increases 53% & 89% in 15m & 18m Span Bridge respectively when it compares with 10m span bridge.

REFERENCES

- [1] Francis T. K. AU and Cliff C. Y. LEUNG, Full-Range Analysis of Multi-Span Prestressed Concrete Segmental Bridges, Journal of Bridge Engineering, Vol. 12, No. 2, March 1, 2007.
- [2] AASHTO LRFD (2006), "Standard Specification for highway Bridges", 16th ed., American Association of state highway and transportation officials, Washington, D.C.
- [3] "Analysis of T-beam Bridges using Finite Element Method". R. Shreedhar Spurti Mamapur International Journal of Engineering and Innovative Technology (IJEIT). Volume 2, Issue 3, September 2012. PP 340-346.
- [4] "Comparative Study of Grillage and Finite Element Method of RCC Bridge Deck". R. Shreedhar and Rashmi Kharde. Volume 4, Issue 2, February 2013.