

THERMAL AND PARAMETRIC ANALYSIS OF PIN-FIN: VOL 2

Karan Sangaj¹, Sudarshan Shinde², Rameez Shanediwan³, Apurva Potdar⁴, Aditya Suryawanshi⁵

^{1,2,3,4,5} UG, Department of Mechanical Engineering, KIT's College of Engineering, Kolhapur, India.

Abstract - The purpose of this study is to give an overview of the Fins and description of recent improvement of fin geometries that increase the heat transfer rate. The objective or main purpose of this project is to improve the performance of the fins using different geometry and material. In recent years, advance devices generate and dissipate tremendous amount of heat and power. For many cooling applications these devices has become a major challenge. Older style heat sinks were often insufficient for cooling newer, hotter running components. So for determining optimum fin geometry, we have considered different shapes (rectangular, circular, tapered, conical, parabolic etc.) and different materials (copper, aluminum, mild steel, brass, stainless steel). Through analysis of different pin-fin geometries (combination of one of the shapes with different material), we have calculated heat transfer rate and optimized with all aspects to get higher heat transfer rate. In the present work, Experiments have been conducted to find the temperature distribution within the pin fin made of different material and geometries and steady state heat transfer analysis has been carried using a finite element software ANSYS to test and validate results. The temperature distribution at different regions of pin fin are evaluated by FEM and compared with the results obtained by experimental and analytical work. The principle implemented in this project is to increase the heat dissipation rate by using the invisible working fluid, nothing but air. We know that, by increasing the surface area we can increase the heat dissipation rate. The main aim of the project is to optimize the thermal properties by varying geometry, material and thickness of fins.

Key Words: Thermal Analysis, Pin-Fin, Optimization, Parametric Analysis, Heat Transfer, ANSYS, Material Selection.

1. INTRODUCTION

In this previous volume [1], we have discussed the objectives, design parameters and factors affecting the performance of heat transfer. We have also discussed the manufacturing process, instrumentation and working of experimental setup. Design parameters such as material selection, fin shapes, air flow directions and flow cross section area are discussed. This volume mainly consists of problem definition and the methodology. Methodology is further divided into two parts-thermal analysis and Experimentation. In first part, thermal analysis of pin-fin is carried out and enhancement of convective heat transfer coefficient is done. Thermal analysis is carried out on different fin shapes and different materials. Later to validate thermal analysis results experimentation is carried out.

2. PROBLEM DEFINITION

In recent years, cooling advance devices such as crucial components of personal computers or internal combustion engine has become a major challenge. Traditional style heat sinks are inadequate for advance devices which generate and dissipate astounding levels of heat and power. Fins are used in following application [2].

1. Radiators of automobiles.
2. Air cooling of cylinder heads of IC engines.
3. Economizers of steam power plant.
4. Heat exchangers of wide variety, used in different industries.
5. Cooling of electric motors, transformers, etc.

So for cooling above components is vital consideration of this study. Thus we have to determine optimum fin geometry and material. In simulation different pin-fin geometries like rectangular, circular, tapered, conical, parabolic etc. and different materials such as copper, aluminum, mild steel, brass, stainless steel are analyzed.

3. METHODOLOGY

EXPERIMENTATION SCHEMES

1. Study various research papers and collecting required Information related for manufacturing of pin-fin setup.
2. Manufacturing of the setup.
3. Testing of various parameters of the manufactured setup.
4. To define the shape & size of the pin-fin geometry
5. Then to create a CATIA model of that fin geometry.
6. Manufacturing of prepared circular type CATIA model of pin-fin.
7. Performed the experiment on circular type pin-fin.
8. Observing the experimental parameter and carried out the Calculations to obtain heat transfer rate and efficiency.

DESIGN AND DEVELOPMENT OF EXPERIMENTAL SETUP

1. Designing of manufacturing setup.
2. Designing of different geometry of pin-fin.

3. To check Thermal analysis of different pin-fin geometry on ANSYS.

4. Select most efficient fin among different shape and materials.

5. Comparison of Experimental data and software results.

4. DIFFERENT PIN FIN SHAPES

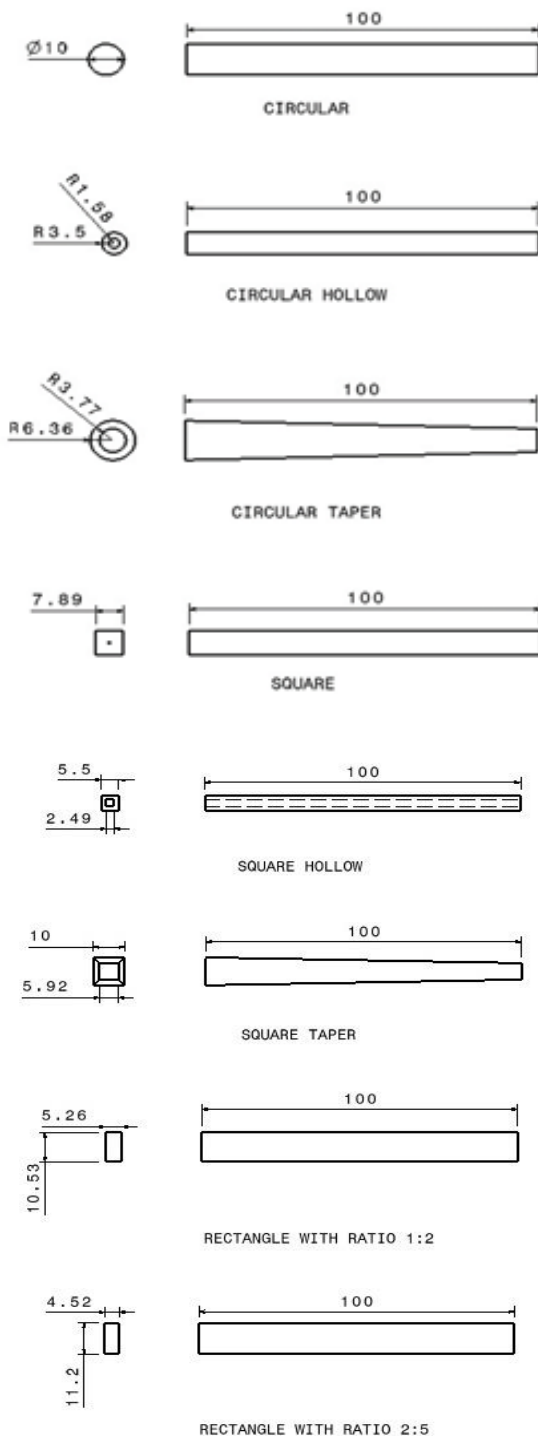

FIG 1: Fin shapes.

4.1 OBSERVATIONS

Physical parameters	Values	
Ambient temperature	30 °C	
Base temperature	100 °C	
Heat transfer coefficient	10w/m ² °C	
Thermocouple Distances (for L=100mm)	Probe no	Distances
	1	05 mm
	2	35 mm
	3	65 mm
	4	95 mm

TABLE 1: Assumptions.

Physical parameters	Values
Base plate dimension (cm)	12 x12
Length of fins (mm)	100
Diameter of Circular fin (mm)	10
Rectangular fin dimension (mm)	7.9 x 7.9
Circular Hollow fin dimension (mm)	R=3.5 r=1.576
Square Hollow fin dimension (mm)	S= 5.5 x 5.5 S= 2.49 x 2.49
Square Taper fin dimension (mm)	A= 10 x 10 B= 5.92 x 5.92
Circular Taper fin dimension (mm)	R= 6.36 r= 3.77
Rectangular fin dimension (mm)	H= 14.03 W= 1.75
Material	Copper/ Aluminium

TABLE 2: Geometry Details.

5. GEOMETRICAL PARAMETER OPTIMIZATION ON PARTICULAR SHAPE OF PIN FIN

In this case, the geometrical parameters are optimized for particular shape of pin fin. The geometrical parameters like diameter, length, side, aspect ratio are optimized. The geometrical parameters are so selected that it gives optimum heat flux, maximum end temperature and optimum Heat transfer coefficient.

5.1 CIRCULAR PIN FIN

Dimension (mm)	Min Temp (°C)	Heat Flux (W/m ²)	Area (mm ²)
D=10 L=100	96.266	30215	3220.13

D=10 L=125	94.385	35796	4005.53
D=12.5 L=100	96.932	27957	4049.70
D=12.5 L=125	95.384	38446	5031.45

TABLE 3: Heat flux and minimum temperature for copper circular fin with varying geometrical parameters.

From above tables we conclude

1. When length is increased by 25% keeping diameter constant, it is observed that there is 18.47% increase in heat flux.
2. When diameter is increased by 25% keeping length constant, it is observed that there is 7.47% decrease in heat flux.
3. When both length and diameter is increased by 25%, it is observed that there is 27.24% increase in heat flux.

Dimension (mm)	Min Temp (°C)	Heat Flux (W/m ²)	Area (mm ²)
D=10 L=100	93.251	29301	3220.13
D=10 L=125	90.042	34183	4005.53
D=12.5 L=100	94.418	27246	4049.70
D=12.5 L=125	91.732	37012	5031.45

TABLE 4: Heat flux and minimum temperature for Aluminum circular fin with varying geometrical parameters.

From above tables we conclude

1. When length is increased by 25% keeping diameter constant, it is observed that there is 16.66% increase in heat flux.
2. When diameter is increased by 25% keeping length constant, it is observed that there is 7.01% decrease in heat flux.
3. When both length and diameter is increased by 25%, it is observed that there is 26.31% increase in heat flux.

5.2 RECTANGULAR PIN FIN

Aspect Ratio	Width (mm)	Height (mm)	Fraction
4:5	7.0173	8.7716	0.800
3:4	6.7667	9.0222	0.750
2:3	6.3156	9.4734	0.666
1:2	5.2630	10.5260	0.500
2:5	4.5111	11.2778	0.400
1:3	3.9472	11.8417	0.333
1:4	3.1578	12.6312	0.250

1:5	2.6315	13.1575	0.200
1:6	2.2555	13.5334	0.166
1:8	1.7543	14.0346	0.125

TABLE 5: Different aspect ratio of Rectangular pin fin.

Aspect Ratio	Heat Flux (W/m ²)	End Temp (°C)
7:8	37824	95.376
3:4	37848	95.309
2:3	39774	95.228
1:2	41230	94.889
2:5	43558	94.486
1:3	46549	94.058
1:4	52379	93.165
1:5	59937	92.258
1:6	66373	91.362
1:8	80173	89.600

TABLE 6: Heat flux and minimum temperature for copper Rectangular fin with varying Aspect Ratio.

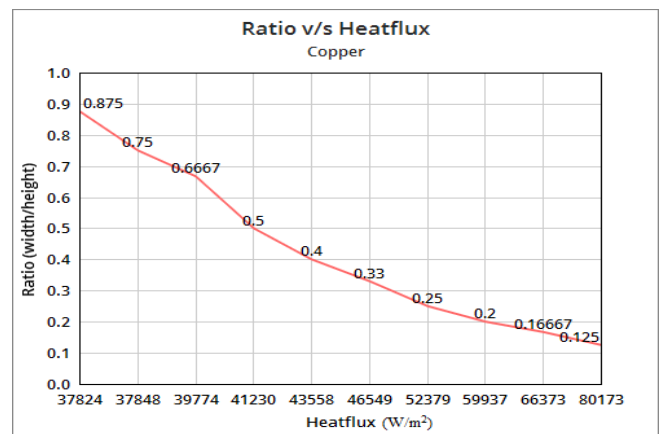

FIG 2: Aspect Ratio v/s Heat flux for Copper Rectangular fin.

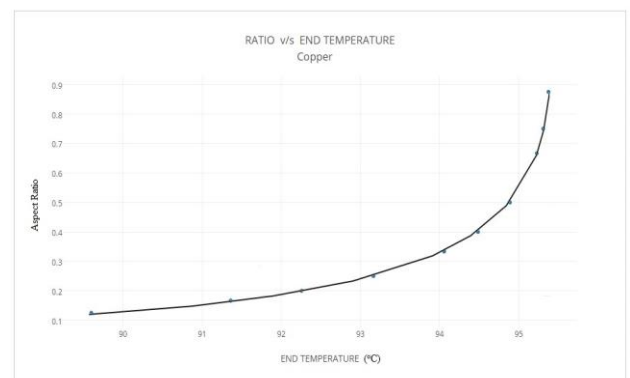

FIG 3: Aspect Ratio v/s End Temperature for Copper Rectangular fin.

Aspect Ratio	Heat Flux (W/m ²)	End Temp (°C)
7:8	36402	91.718
3:4	36406	91.604
2:3	38236	91.465
1:2	39529	90.891
2:5	41628	90.212
1:3	44337	89.497
1:4	49546	88.024
1:5	56304	86.556
1:6	61928	85.130
1:8	73828	82.400

TABLE 7: Heat flux and minimum temperature for Aluminum Rectangular fin with varying Aspect Ratio.

Aspect Ratio	Width(mm)	Height(mm)	Fraction	Pc(mm)
4:5	7.0173	8.7716	0.800	31.577
3:4	6.7667	9.0222	0.750	31.577
2:3	6.3156	9.4734	0.666	31.577
1:2	5.2630	10.526	0.500	31.577
2:5	4.5111	11.277	0.400	31.577
1:3	3.9472	11.841	0.333	31.577
1:4	3.1578	12.631	0.250	31.577
1:5	2.6315	13.157	0.200	31.577
1:6	2.2555	13.533	0.166	31.577
1:8	1.7543	14.034	0.125	31.577

TABLE 8: Various parameters for different aspect ratio of rectangular fin.

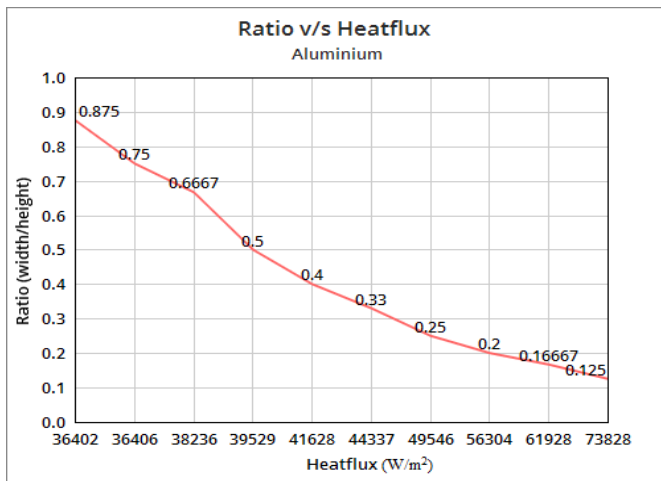

FIG 4: Aspect Ratio v/s Heat flux for Aluminum Rectangular fin.

Aspect Ratio	As(mm ²)	Ac(mm ²)	M	Heat Flux (W/m ²)
4:5	3157.79	61.5533	0.1581	36402
3:4	3157.79	61.0505	0.1588	36406
2:3	3157.79	59.8302	0.1604	38236
1:2	3157.79	55.3983	0.1667	39529
2:5	3157.79	50.8755	0.1740	41628
1:3	3157.79	46.7423	0.1815	44337
1:4	3157.79	39.8868	0.1965	49546
1:5	3157.79	34.6239	0.2109	56304
1:6	3157.79	30.5245	0.2246	61928
1:8	3157.79	24.6209	0.2501	73828

TABLE 9: Various parameters for different aspect ratio of rectangular fin.

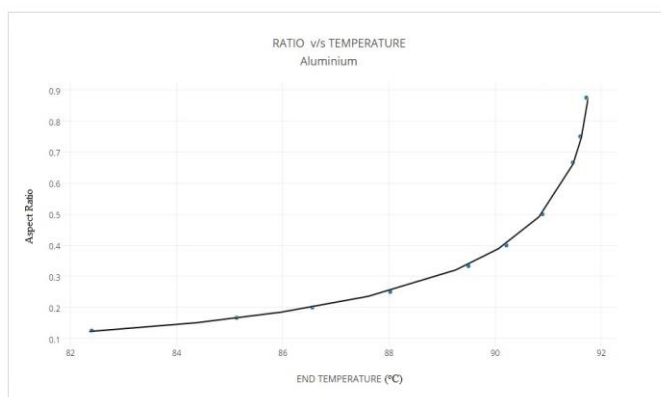

FIG 5: Aspect Ratio v/s End Temperature for Aluminum Rectangular fin.

From above table it is observed that cross sectional area of pin fin is responsible for conduction through pin fin and surface area of pin fin is responsible for convection through pin fin. We have done analysis keeping perimeter ,surface area and length constant.as ratio is decreased the cross sectional area is decreased and m is increased.as we know the m is directly proportional to heat flux, so when m is increased there is increase in heat flux.

6. SELECTION OF BEST SUITABLE MATERIAL AND SHAPE

In this case, the different shapes and material are selected for optimum heat transfer rate. The Shape and material are so selected that it gives optimum heat flux, maximum end temp and optimum Heat transfer coefficient. Calculations are made by keeping the area of all shapes constant. In these case , area of different geometries is 3220.13 mm² .also the length of different geometries is kept constant which is 100mm.the different shapes considered are Circular,

From above tables we conclude:

It is observed that as aspect ratio decreases the heat flux increases. The reason behind can be explained from following table

Circular hollow, Circular taper, Square, Square hollow, Square taper.

Shape	Dimension (mm)	End Temp (°C)	Heat Flux (W/m ²)
Circular	D = 10	93.251	29301
Square	7.9 x 7.9	91.749	36410
Circular hollow	R=3.5 r=1.576	84.985	82855
Square hollow	S=5.5x5.5 s=2.49x2.49	81.847	79092
Circular taper	R=6.36 r=3.77	96.123	16197
Square taper	A=10x10 B=5.92x5.92	93.378	25971
Rectangle	H = 14.0346 W=1.7543	82.400	73823

TABLE 11: Heat flux and minimum temperature for Aluminum material fin with varying fin shapes.

Shape	Dimension (mm)	End Temp (°C)	Heat Flux (W/m ²)
Circular	D = 10	96.266	30215
Square	7.9 x 7.9	95.394	37842
Circular hollow	R=3.5 r=1.576	91.270	88805
Square hollow	S=5.5x5.5 s=2.49x2.49	89.236	86051
Circular taper	R=6.36 r=3.77	97.892	16446
Square taper	A=10x10 B=5.92x5.92	96.344	26670
Rectangle	H = 14.0346 W=1.7543	89.600	80173

TABLE 10: Heat flux and minimum temperature for copper material fin with varying fin shapes.

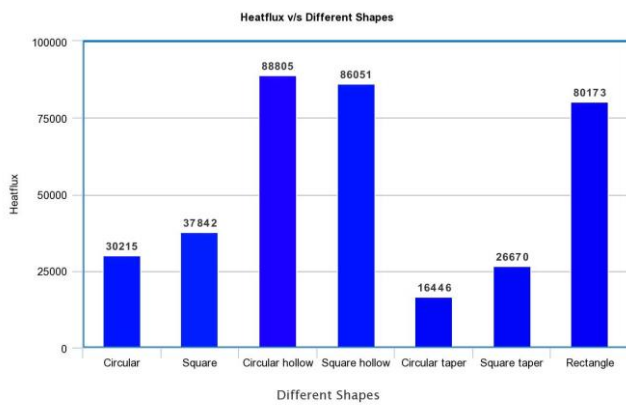

FIG 6: Heat flux v/s Different shapes for Copper Material.

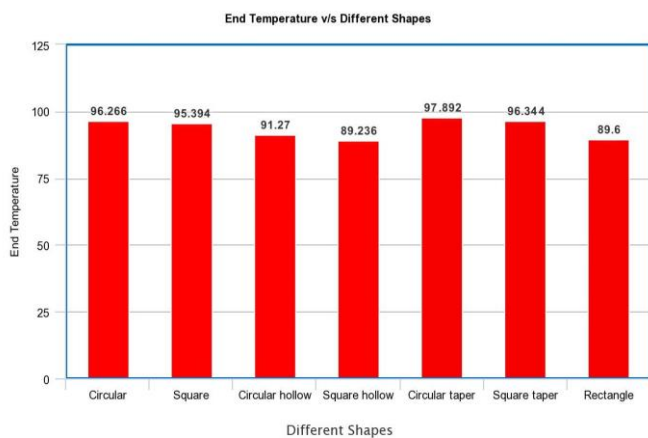

FIG 7: End Temperature v/s Different shapes for Copper Material.

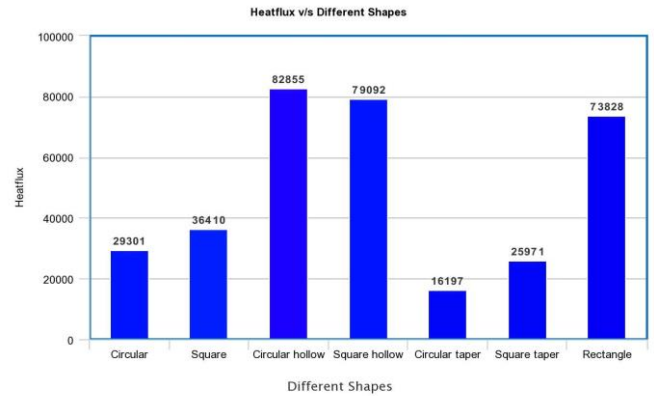

FIG 8: Heat flux v/s different shapes for Aluminium Material.

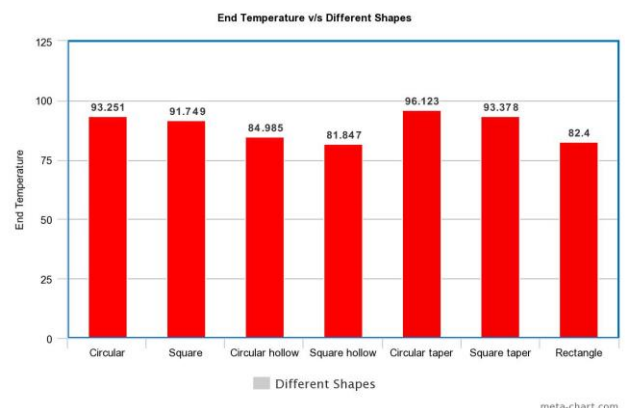

FIG 9: End Temperature v/s Different shapes for Aluminium Material.

From above tables we conclude:

The analysis work is carried out keeping length and surface area constant for different shapes of pin fin. As surface area

is kept constant, the heat transferred by convection is constant. In this case heat transfer by convection and radiation is changed with respect to different pin fin shapes. Shape with more cross sectional area have less heat flux while pin fin with less cross sectional area have more heat flux. From above tables it is found that rectangular fins have maximum heat flux. Another observation is that fin with same shape with copper and aluminum material transfer nearly same amount of heat flux. Due to economic constraints we have chosen aluminum as most efficient material. Circular hollow and square hollow can't be manufactured due to some constraints at our level, so we have manufactured rectangular pin fin. so the most optimum fin selected is aluminum rectangular pin fin.

7. THERMAL ANALYSIS

7.1 HEAT FLUX DISTRIBUTION

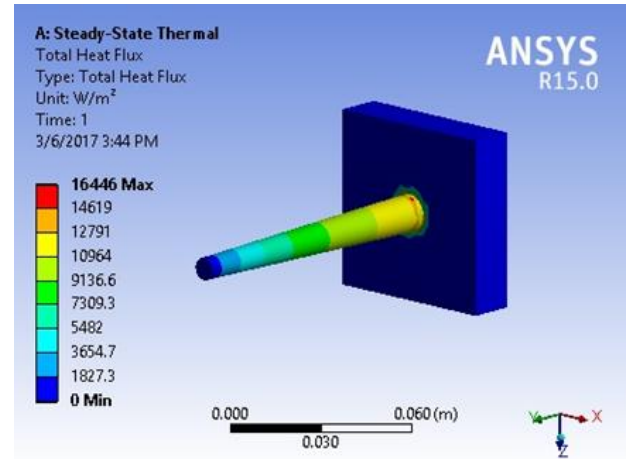

FIG 12: Heat flux distribution for Circular Taper fin. From above figure it is observed that maximum heat flux is 16446 (W/m²).

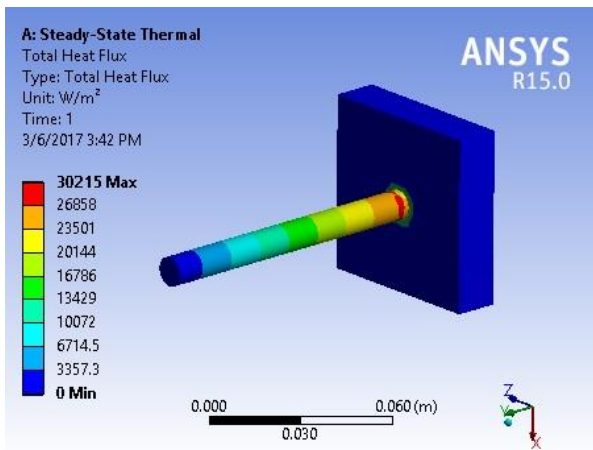

FIG 10: Heat flux distribution for Circular fin. From above figure it is observed that maximum heat flux is 30215 (W/m²).

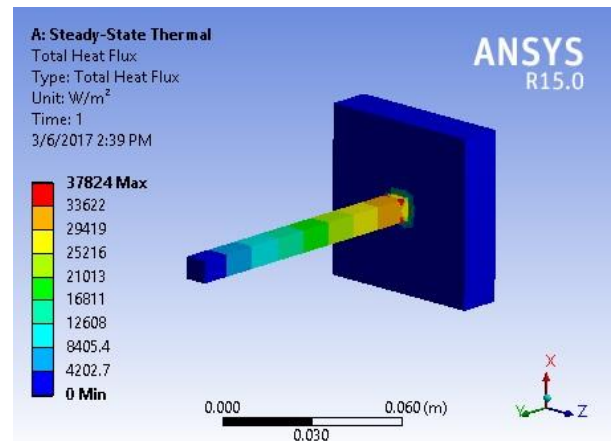

FIG 13: Heat flux distribution for Square fin. From above figure it is observed that maximum heat flux is 37824 (W/m²).

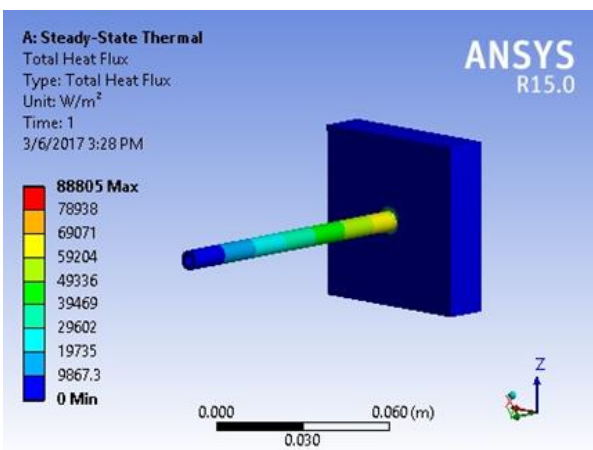

FIG 11: Heat flux distribution for Circular Hollow fin. From above figure it is observed that maximum heat flux is 88805 (W/m²).

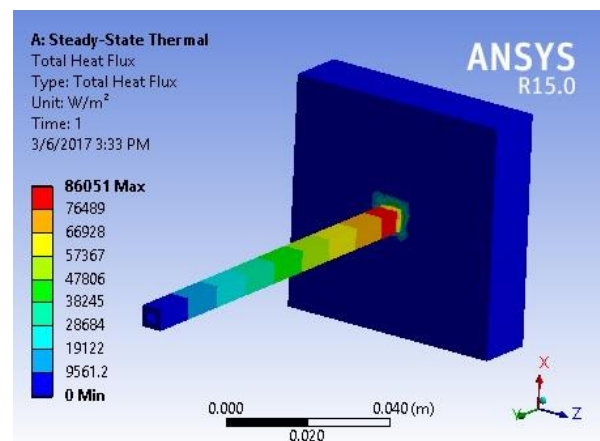

FIG 14: Heat flux distribution for Square Hollow fin. From above figure it is observed that maximum heat flux is 86051 (W/m²).

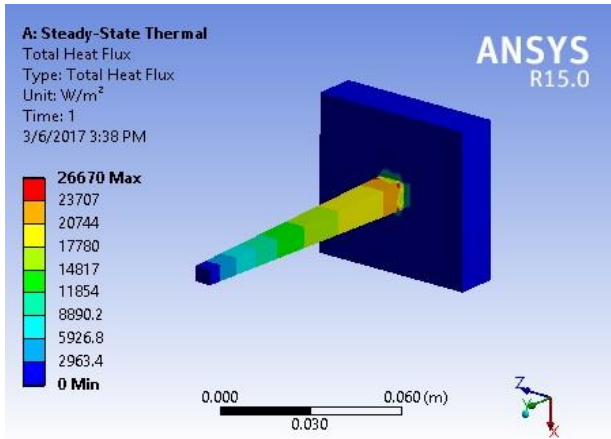

FIG 15: Heat flux distribution for Square Taper fin. From above figure it is observed that maximum heat flux is 26670 (W/m²).

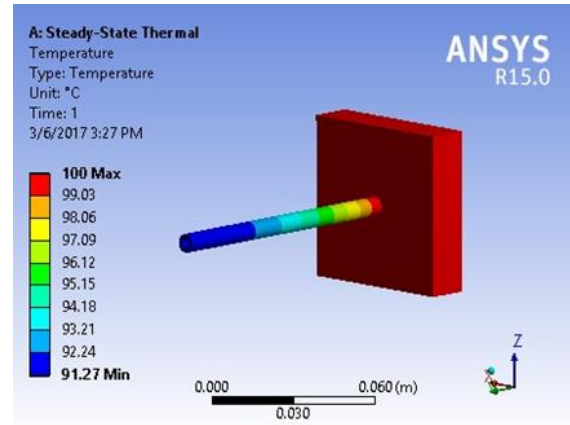

FIG 18: Temperature distribution for Circular Hollow fin. From above fig it is observed that minimum end temperature is 91.27 (°C).

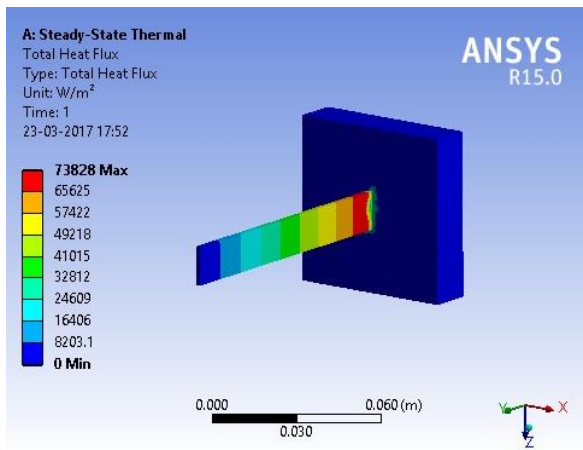

FIG 16: Heat flux distribution for Rectangular fin. From above fig it is observed that maximum heat flux is 73828(W/m²).

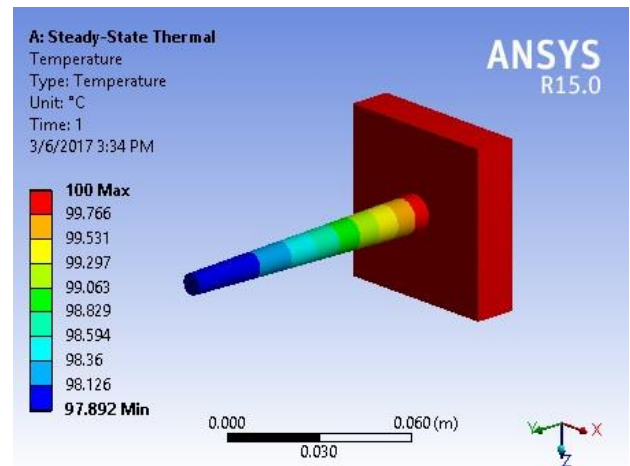

FIG 19: Temperature distribution for Circular Taper fin. From above fig it is observed that minimum end temperature is 97.892 (°C).

7.2 TEMPERATURE DISTRIBUTION

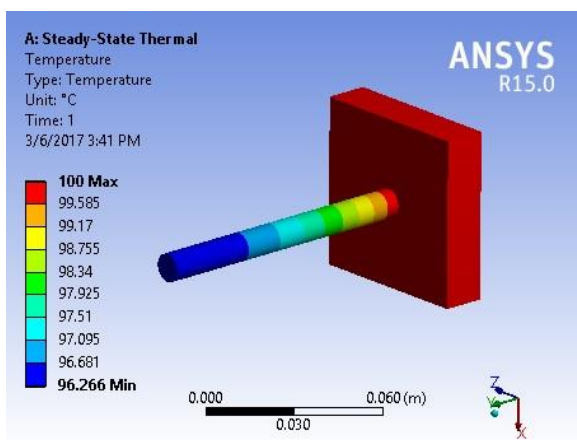

FIG 17: Temperature distribution for Circular fin. From above fig it is observed that minimum end temperature is 96.266 (°C).

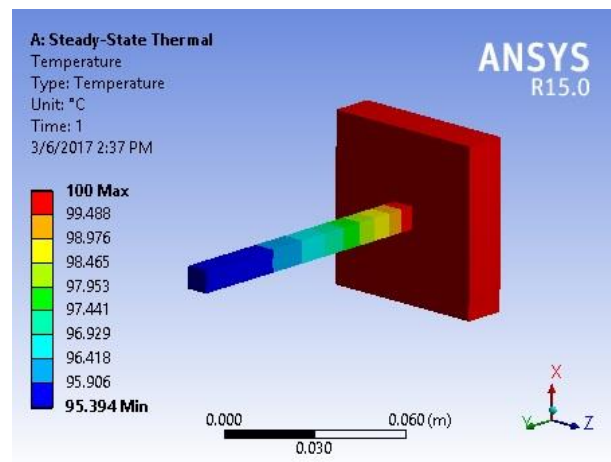

FIG 20: Temperature distribution for Square fin. From above fig it is observed that minimum end temperature is 95.394 (°C).

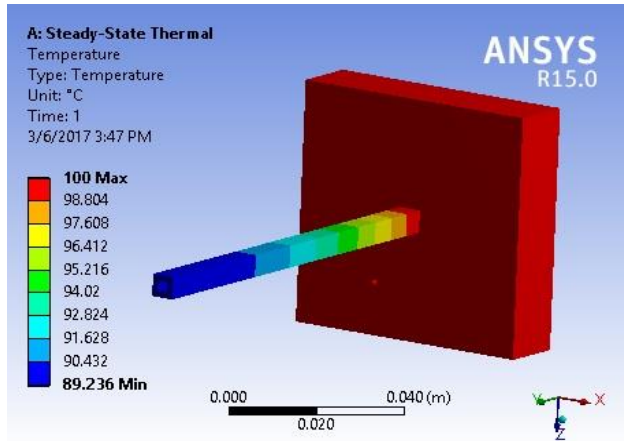

FIG 21: Temperature distribution for Square Hollow fin. From above fig it is observed that minimum end temperature is 89.236 (°C).

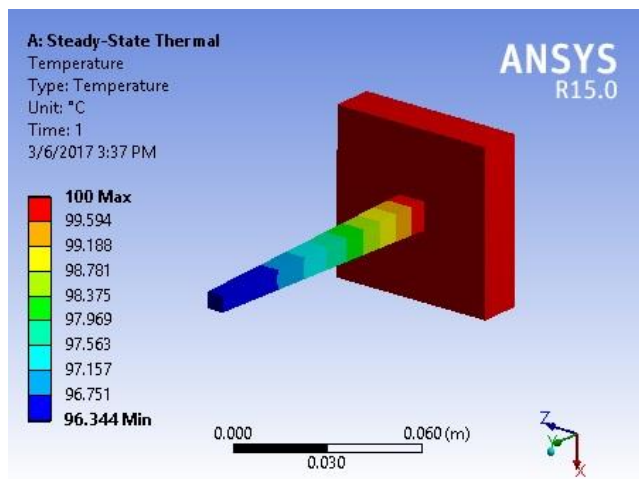

FIG 22: Temperature distribution for Square Taper fin. From above fig it is observed that minimum end temperature is 96.344 (°C).

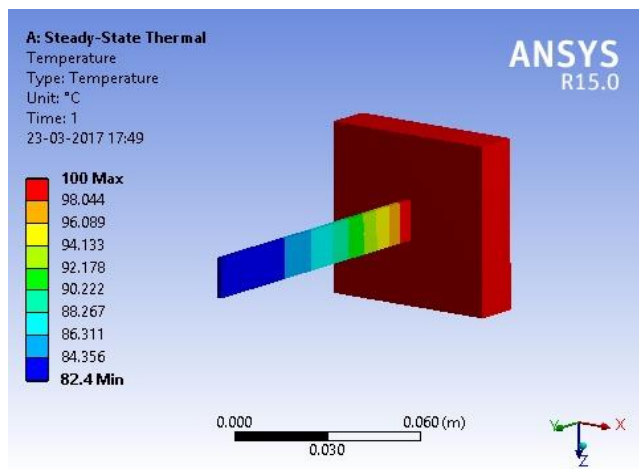

FIG 23: Temperature distribution for Rectangular fin. From above fig it is observed that minimum end temperature is 82.4 (°C).

8. RESULTS

8.1 COMPARISON BETWEEN RESULTS

Sr No	Heat transfer coefficient (h)	Heat Transfer(Q)	Efficiency (η)
	w/m ² k	watts	%
1.	37.94	23.51	78.66
2.	38.42	17.13	78.46
3.	42.09	16.78	76.98
4.	48.95	15.97	74.36

TABLE 12: Heat transfer coefficient and Efficiency.

Sr No.	Thermocouples	Temperatures (°C)		
		Experimental	Analytical	Ansyz
1	T1	53.0	69.07	68.69
	T2	52.0	63.23	61.42
	T3	51.1	59.78	57.15
	T4	50.5	58.43	55.43
2	T1	46.1	58.90	58.63
	T2	45.2	54.65	53.33
	T3	44.8	52.13	50.23
	T4	44.2	51.15	48.98
3	T1	42.8	56.52	56.25
	T2	42.5	52.37	51.12
	T3	42.2	49.93	48.13
	T4	42.0	48.98	46.93
4	T1	41.3	52.76	52.52
	T2	41.0	48.84	47.72
	T3	40.8	46.56	44.96
	T4	40.2	45.68	43.87

TABLE 13: Comparison between experimental, analytical and Ansys results.

8.2 GRAPHS

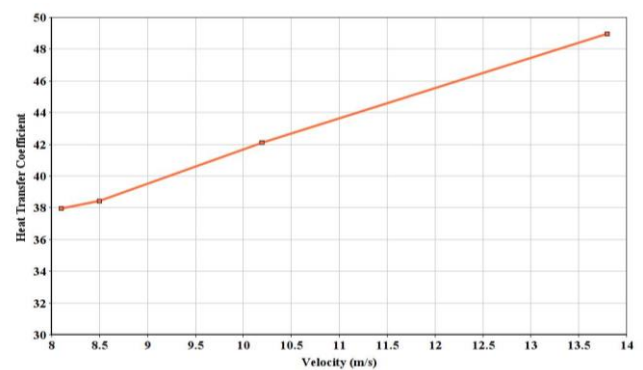

FIG 24: Velocity v/s Heat Transfer Coefficient.

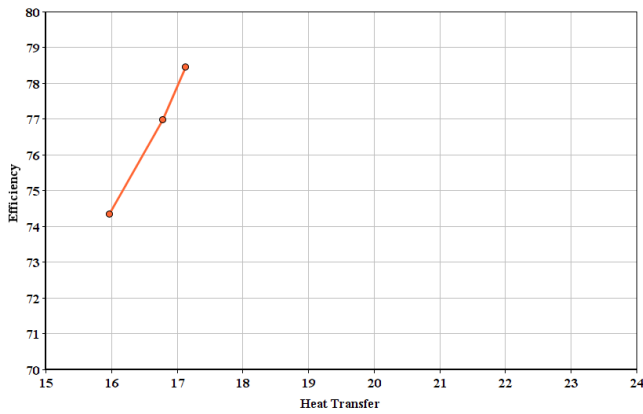

FIG 25: Efficiency v/s Heat Transfer Coefficient.

8.3 TEMPERATURE DISTRIBUTION.

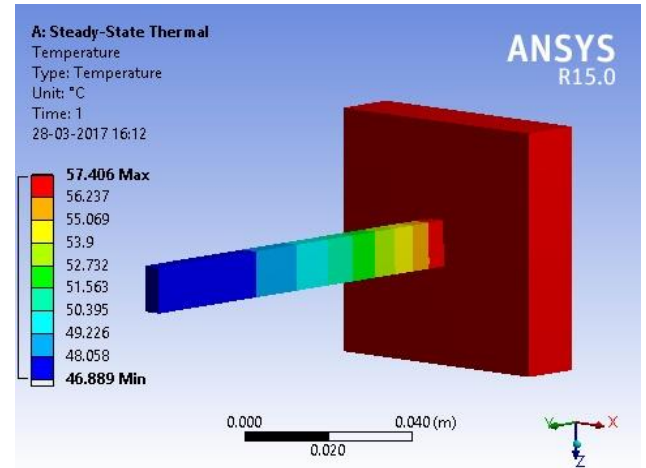

FIG 28: Temperature Distribution $h = 42.09 \text{ w/m}^2\text{k}$, base temperature = $57.4 \text{ }^\circ\text{C}$.

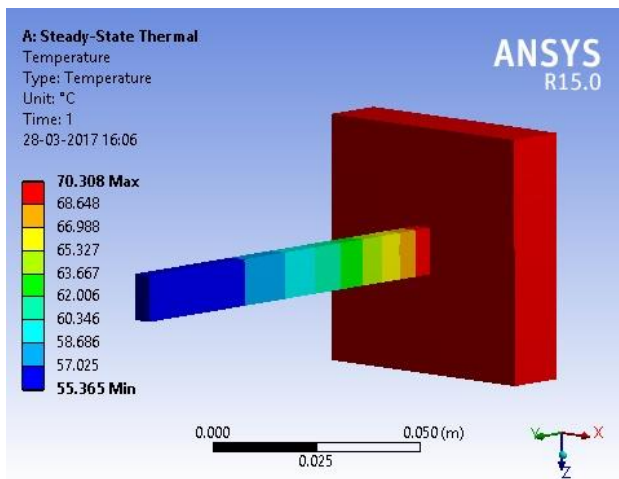

FIG 26: Temperature Distribution $h = 37.94 \text{ w/m}^2\text{k}$, base temperature = $70.3 \text{ }^\circ\text{C}$.

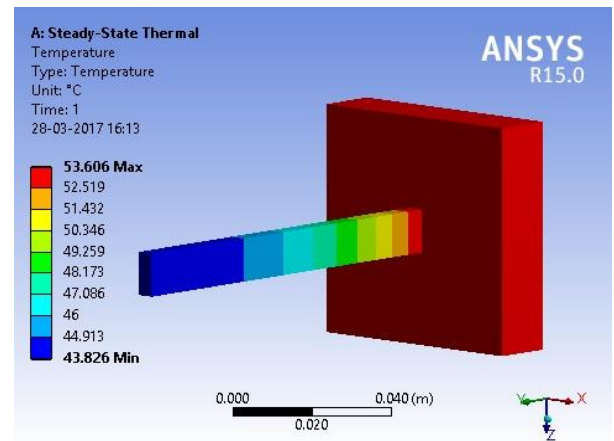

FIG 29: Temperature Distribution $h = 48.95 \text{ w/m}^2\text{k}$, base temperature = $53.6 \text{ }^\circ\text{C}$.

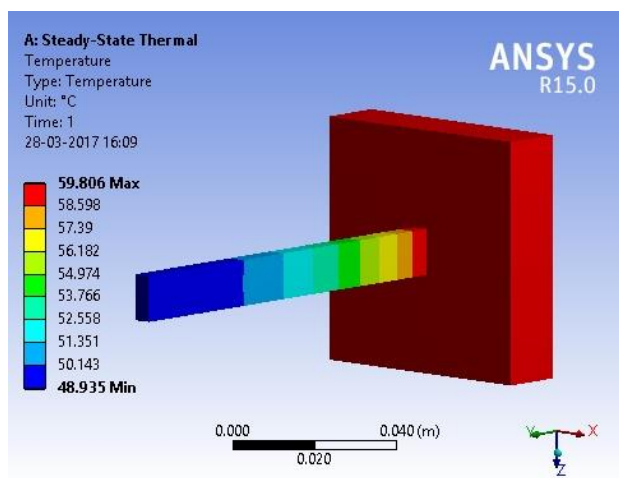

FIG 27: Temperature Distribution $h = 38.42 \text{ w/m}^2\text{k}$, base temperature = $59.8 \text{ }^\circ\text{C}$.

9. CONCLUSION

- 1) The present work is successfully carried out by comparing various parameters (shape, geometry, material) of pin-fin. The different types of shape and material are chosen for the comparison. Analysis has been carried out in ANSYS.
- 2) In above context we have carried out:
 - a) Geometrical Parameter optimization on particular shape of pin fin
 - b) Selection of best suitable material and shape from different shapes and material available for pin fin
- 3) From above two cases it is found that copper circular hollow pin-fin and copper rectangular pin-fin are the most optimum pin-fins, but due to economic constraints and from above observations it is found that copper and aluminium fins with same shape have nearly same heat transfer rates, so we have selected aluminium as the most optimum material for pin-fin. Due to manufacturing constraints we can't manufacture circular hollow pin-fin and rectangular

pin-fin with aspect ratio 1:8 so we have manufactured aluminium rectangular pin-fin we aspect ratio 2:5.

9.1 FUTURE SCOPE

1) The shape of the fin can be modified to improve the heat transfer rate and can be analyzed.

2) As the improvements in the technologies are been taking place, there is need for the development in the pin-fin for increasing the heat transfer rate and various parameters

10. REFERENCES

1. "Thermal and parametric analysis of pin-fin: vol 1" / IRJET Volume: 05 Issue: 02 | Feb-2018 / e-ISSN: 2395-0056 / p-ISSN: 2395-0072.

2. "Fundamentals of Heat and Mass Transfer" - M. Thirumaleshwar / Pearson Education India, 2009 / 8177585193, 9788177585193 / Pg.222.