

DESIGN AND IMPLEMENTATION OF SECURED VEHICLE SYSTEM

R.Subraja¹, S.Oviya², R.Suguna³, R .Tamil Selvi⁴

¹Assistant Professor, Electronics and Communication Engineering, Jeppiaar SRR Engineering College, Chennai, TN

^{2,3,4}Student, Electronics and Communication Engineering, Jeppiaar SRR Engineering College, Chennai, TN

Abstract - Accident may occur with some marked effect due to unpredictable and unintended external action with no apparent. In day-to-day life, all over the countries are pressurizing the vehicle rider to follow the certain rule such as to wear the helmet and also the riding should be prohibited when the person is in drunken condition and also when the rider is on phone. But still the rules are being violated by the users. In order to overcome this we introduce an embedded based intelligent system. Smart Helmet system, which automatically detects whether the person is wearing the helmet and at the same time as non- alcoholic breath while riding. But the main aim of our proposal is to develop prototype of black box for wheeled vehicle analysis that can be retrofit into any vehicle. This prototype can be designed with minimum number of circuits. This can contribute to construct safer vehicles, improving the treatment for crash victims, helping insurance companies with their vehicle crash investigations, police investigations and enhancing road status in order to decrease the death rate. Its potentially life -saving features include accelerometers, real time clock, ultrasonic distance meter. Together the features provide the rider with information while riding or data in the event of an accident.

Key Words: LCD, GPS, Alcoholic sensor, Ultrasonic sensor, MEMS, SD CARD.

1. INTRODUCTION

The main objective of the project is to provide the black box for cyclist, bike, car and heavy vehicle. The black box is the digital event data recorder. The concept is similar to the "black box" data recorder on airplanes. It records all the information like speed, time and location, before and after the accidents so that it can be used to analyze the accident accordingly.

A green indicator light shows that the system is armed and ready to capture an event. As soon as a collision is detected automatically, the indicator light will turn red and start recording all the relevant, data during a pre- defined period before and after the accident that will display immediately on a LCD at the same time all the data will automatically store in SD card storage for future use.

2. EXISTING SYSTEM:

- ✓ There are many electronic devices and systems are used to provide to track the vehicle.

- ✓ The person met with an accident then the smart helmet will send a message to the nearer hospital through the RF signal.
- ✓ Here we have a RF transmitter at the helmet and the RF receiver at the bike. IR signals are used to sure the wearing of helmet on the head.

3. PROPOSED SYSTEM:

- ✓ The proposed system is specially for the vehicle safety and overcomes the disadvantages of existing systems such that it is possible if only the rider wear the helmet and also it is only applicable for bike user.
- ✓ In this proposed system approach the black box for cyclists, bike, car, heavy vehicles has built-in data recorder to capture the moment a person crashes.
- ✓ The 'black box' has accelerometers and sensors to work out what happened. It also records the rider's distance, alcoholic condition and direction at all times.
- ✓ All of the data from the crash can then be studied after to understand what happened.
- ✓ To not only record the relevant data, but also try and prevent a possible collision by limiting the speed of the vehicle in accident-prone areas.

4. METHODOLOGY:

In Vehicle Network based Black Box consists of ATMEGA 2560 processor of embedded system, various sensors like ultrasonic sensor, alcohol detector, SD controller dumping the data from memory buffer to SD card, collision detector, GPS module. These hardware modules are integrated in only one chip. We implement the whole hardware onto a single PCB board. Processor initialize all sensors and SD controller and also receives data from GPS. Arduino Processor not only recognizes the crash through interrupt pin connected with Collision Detector when vehicle collision is detected but also moves the data of Memory Buffer to SD card by activating SD controller. GPS provides continuously record vehicle position and precise time. For more efficiency, the data recorded will get refreshed on every start of the vehicle for managing limited data storage capacity, unless an accident has taken place.

5. BLOCK DIAGRAM:

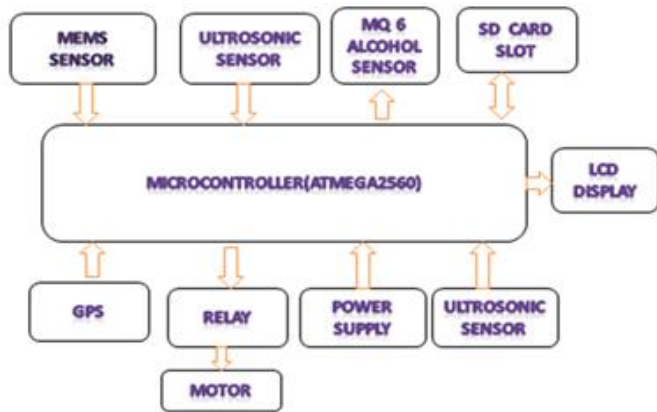

6. HARDWARE DESCRIPTION:

Hardware consists of various components such as ARDUINO atmega 2560, ultrasonic sensor, alcoholic sensor, LCD display, MEMS, SD card, relay, GPS And DC power supply of 5v.

6.1. ARDUINO ATMEGA 2560:

ARDUINO is a microcontroller board based on the atmega 2560. It has 54 digital input/output pins (of which 14 can be used as PWM outputs), 16 analog inputs, 4 UARTs (hardware serial ports), a 16 MHz crystal oscillator, a USB connection, a power jack, an ICSP header, and a reset button. It is an open source board and on-board programming. It is user interface easier and connected USB cable easily. Arduino can be programmed with the arduino software IDE.

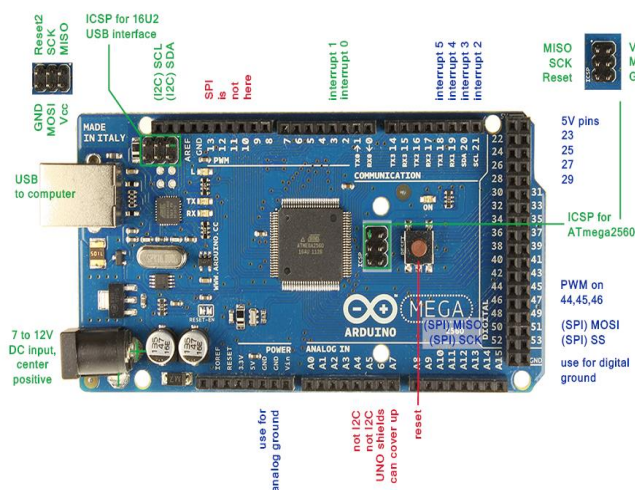

6.2. ALCOHOL SENSOR (MQ-6):

MQ-6 Semiconductor Sensor for Alcohol Sensitive material of MQ-6 gas sensor is SnO₂, which with lower conductivity in clean air. When the target alcohol gas exist, The sensor's conductivity is more higher along with the gas concentration

rising. Convert change of conductivity to correspond output signal of gas concentration.

MQ-6 gas sensor has high sensitivity to Alcohol, and has good resistance to disturb of gasoline, smoke and vapour. The sensor could be used to detect alcohol with different concentration, it is with low cost and suitable for different application.

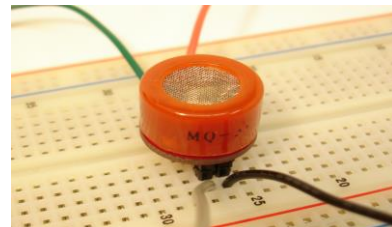

6.2.1.INTERFACING WITH ALCOHOLIC SENSOR:

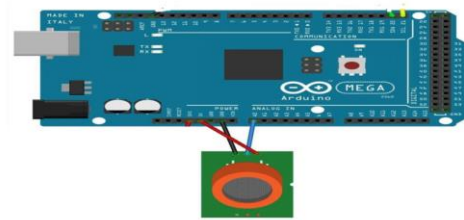

6.2.2.SCHEMATIC DIAGRAM OF ALCOHOL SENSOR:

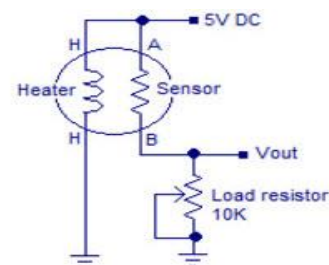

6.3.ULTRASONIC SENSOR(HC-SR04):

The working principle of an ultrasonic sensor is simple and use high-frequency sound waves that are evaluated when the sensor received back the waves. To determine the distance between the vehicle and object, the sensor measure the elapsed time between sending and receiving the waves.

6.3.1.INTERFACING WITH ULTRASONIC SENSOR:

Ultrasonic sensor is a device calculates the distance of objects by emitting a sound wave pulse which reflects off objects. The reflected pulse which is called "echo" is received by the sensor. The actual value evaluated is the time between the emitted and received pulse. Newton's law of motion is used to calculate the distance of the observed time. The module used in this project is Ultrasonic Ranging Module HC - SR04.

In the project Ultra Sonic Sensor is used to measure the distance in meter and according to output, this will measure the distance of the nearest vehicle.

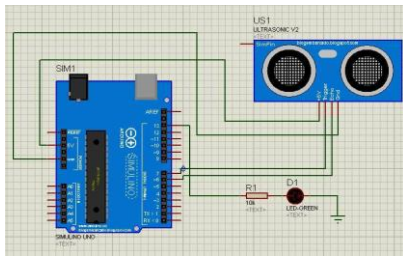

6.3.2.SCHEMATIC DIAGRAM OF ULTRASONIC SENSOR:

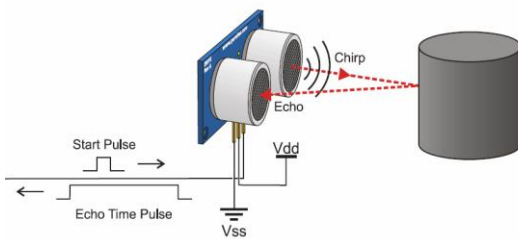

6.4. MEMS SENSOR:

The ADXL345 is a low-power, 3-axis MEMS accelerometer modules with both I2C and SPI interfaces. The Ada fruit Breakout boards for these modules feature on-board 3.3v voltage regulation and level shifting which makes them simple to interface with 5v microcontrollers such as the Arduino. The ADXL345 features 4 sensitivity ranges from +/- 2G to +/- 16G. And it supports output data rates ranging from 10Hz to 3200Hz.

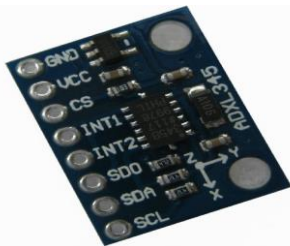

6.4.1. INTERFACING OF MEMS SENSOR:

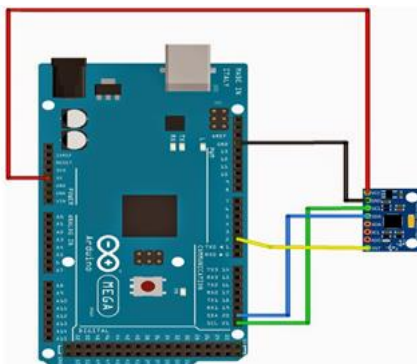

6.4.2.SCHEMATIC DIAGRAM OF MEMS SENSOR:

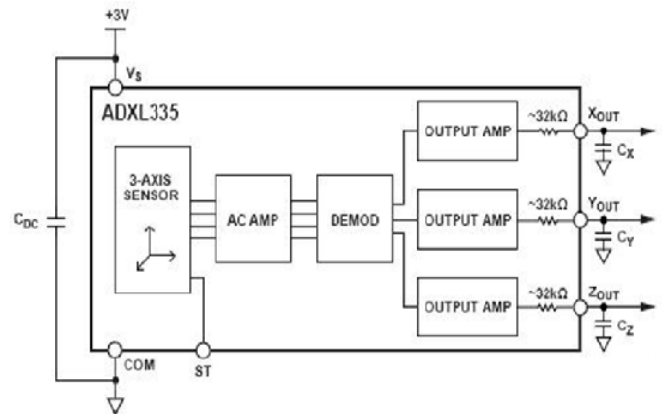

6.5.GLOBAL POSITIONING SYSTEM(NEO-7M):

The principle behind GPS is the measurement of distance (range) between the satellites and the receiver. The satellites tell us exactly where they are in their orbits by broadcasting data and this data in turn is used by the receiver to compute their positions.

Each satellite transmits data that indicates its location and current time. All GPS satellites synchronize operations so that these repeating signals are transmitted at the same instant. These signals moving at the speed of light arrive at the GPS receiver at slightly different times because some satellites are farther away than others. The distance to the GPS satellites can be determined by estimating the amount of time it takes for their signals to reach the receiver. When the receiver estimates the distance to at least four GPS satellites, it can calculate its position in three dimensions.

6.5.1.INTERFACING WITH GPS:

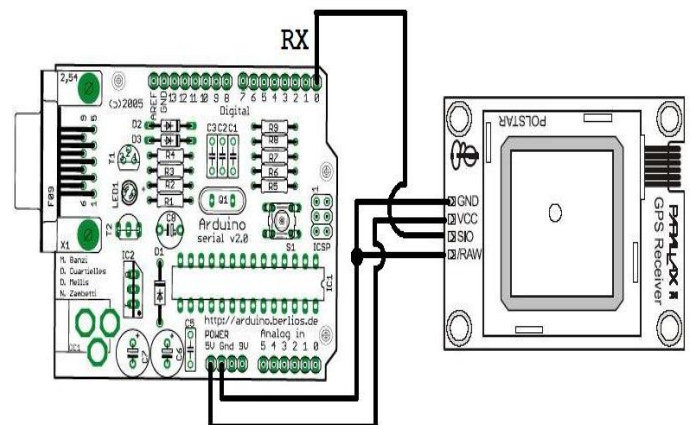

6.6.LCD DISPLAY(16*2):

The standard is referred to as HD44780U, which refers to the controller chip which receives data from an external source (and communicates directly with the LCD).

6.6.1.INTERFACING WITH LCD:

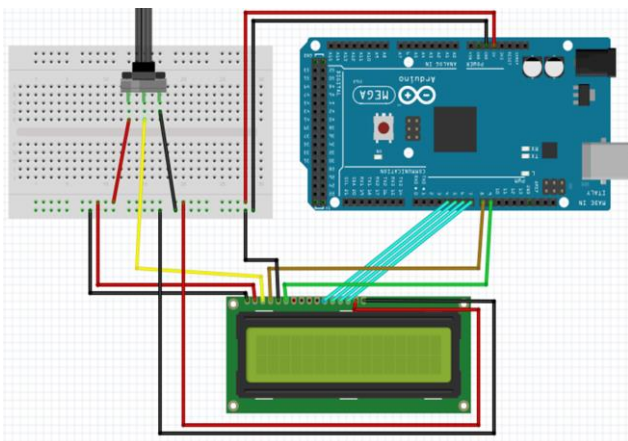

6.8.1.SCHEMATIC DIAGRAM OF RELAY:

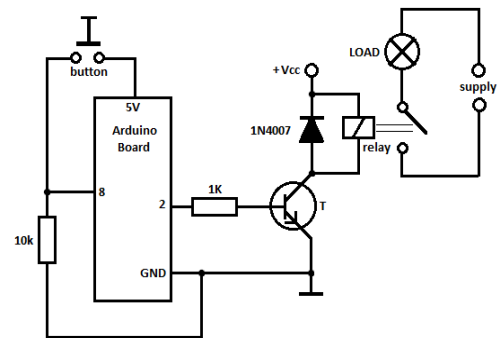

6.7. MICRO SD CARD :

The SD card module can make this application more easier and simpler It is easily interfaced as a peripheral to your module. Through programming you read or write your SD card. All SD SPI pins output MOSI, SCK, MISO and CS.

6.7.1.INTERFACING SD CARD:

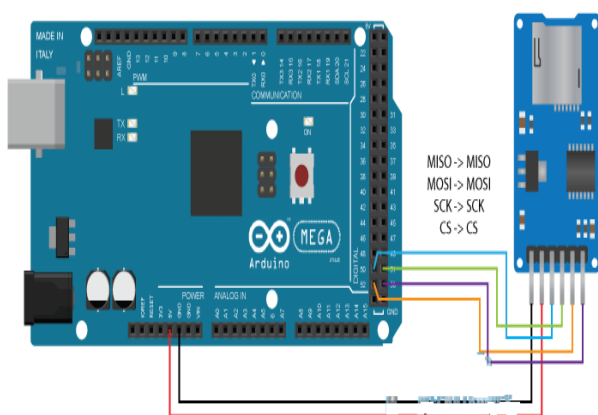

6.8. RELAY:

Relay is an electrical switch that opens and closes under the control of another electrical circuit. The phase of main supply is connected to relay. In this project, if the rider is in alcoholic condition means relay goes to open state and no current passes through motor, suddenly stopped. if rider is in non-alcoholic means relay turns to closed state and motor start running.



6.9.CIRCUIT DIAGRAM:

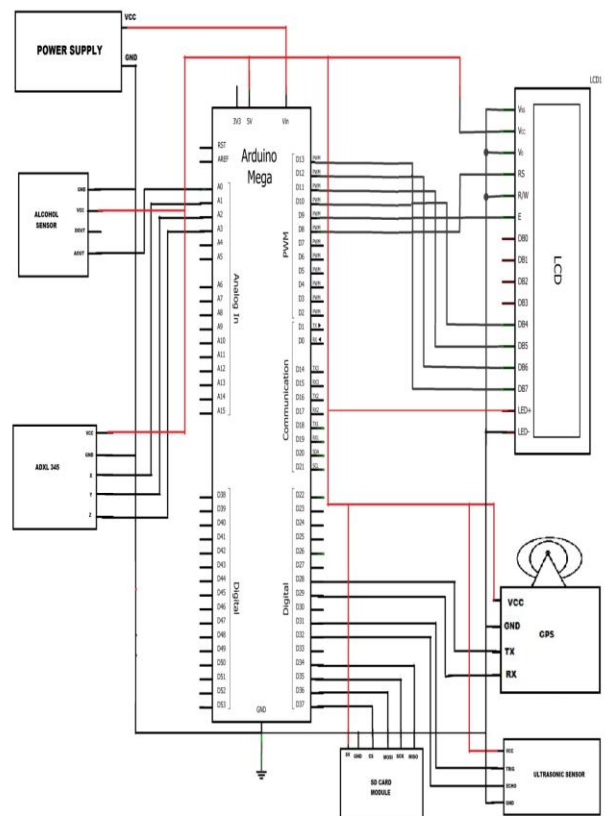

7.HARDWARE INTERFACING:

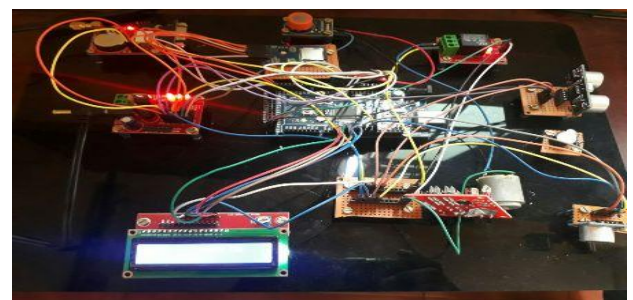

8.CONCLUSION:

Through study and analysis, the black box system for vehicle was studied and implemented. This system based on GPS and Sensor technology and the main component used is ATMEGA 2560 microcontroller for performing input/output operations. This device will be very much useful to all vehicles, whenever they went riding. It is practically possible one and economically comfort to use.

REFERENCE

[1] N.Watthanawisuth, T.Lomasand, A.Tuantranont, "Wireless Black Box Using MEMS Accelerometer and GPS Tracking for Accidental Monitoring of Vehicles", Proceedings of the IEEE-EMBS International Conference on Biomedical and Health Informatics (BHI 2012) Hong Kong and Shenzhen, China, 2-7 Jan 2016.

[2] D.Malan, T.R.F.Fulford-Jones, M.Welsh, S.Moulton, CodeBlue: an ad-hoc sensor network infrastructure for emergency medical care, in: Proceedings of the Mobi-Sys 2015 Work shop on Applications of Mobile.

[3] Jung Lee, "An Accident detection system on highway using vehicle tracking trace", ICT convergence (ICTC), 2011, International Conference, PP.716,721,40-45 sept.2011 [4] Chung-Cheng Chiu, Min-Yu Ku, Hung-Tsung, Chen Nat, "Motorcycle Detection and Tracking System with Occlusion Segmentation" Image Analysis for Multimedia Interactive Services. Santorini, vol. 2, pp. 32-32, June 2017.

[5] Oscar S. Siordia, Isaac Martín de Diego, Cristina Conde, and Enrique Cabello "Wireless in-complaint Box For Accident Analysis" IEEE Vehicular Technology Magazine, Sept 2016.

[6] Fleischer, Paul Benjamin, Nelson, Atso Yao, Sowah, Robert Adjete; Bremang, Appah "Design and Development of GPS/GSM Based Vehicle Tracking and Alert System for the use of commercial inter-City Buses". PROC. ISSCC Dig. Ech. Papers, vol.45, FEB.2015, pp.270-271.

[7] Murugandhan and P.R.Mukesh (2015) "Real Time Web Based Vehicle Tracking Using GPS" world Academy of Science, Engineering and Technology.

[8] Khangura K S, Dearborn, ollivier; "Vehicle Anti Theft system users radio frequency identification" IEEE.

[9] Teng D, Chen, L, Dinh, A, "Data acquisition system using SIX degree -of freedom inertia sensor & Zigbee wireless link for fall detection & Prevention.

[10] N. Jinaporn, S. Wisadsud, P. Nakonrat, A. Suriya, "Security system against asset theft by using radio frequency identification technology," IEEE Trans. ECTI-CON 2016.

[11] A.Rajkiran, M. Anusha, "Intelligent Automatic Vehicle Accident Detection System Using Wireless Communication", IJRSET vol.1, NOV 2016, pp.98-101.

[12] R.Ramani, S.Valarmathy, Dr. N.SuthanthiraVanitha, S.Selvaraju, M.Thirupathi, R.Thangam, "Vehicle Tracking and Locking System Based on GSM and GPS" IJ. Intelligent Systems and Applications Vol.9, Aug 2017, 86-93.