

AGRICULTURAL ROBOT

Kavita Zole¹, Sanghasevak Gedam², Aditya Dawale³, Kiran Nikose⁴, Jayant Hande⁵

¹²³⁴ Research Student, Dept. of ETC, Priyadarshini J L College of Engineering Nagpur, Maharashtra, India

⁵ Guide, Asst. Prof. Dept. of ETC, Priyadarshini J L College of Engineering Nagpur, Maharashtra, India

Abstract – In this paper author tries design agricultural robot which is based on electronic and mechanical (Mechatronics) platform that perform advance agriculture process. This paper strives to develop a robot capable of performing operation like automatic ploughing and seed dispensing. We have developed an electromechanical vehicle which is steered by DC motor to drive wheels. The farm is cultivated by the automated system, depending on the crop considering particular row and specific columns. This project controlled by remotely and solar panel is used to charge DC battery.

Key Words: RF transmitter & receiver, solar panel, remote, DC motor, AT mega 16

1. INTRODUCTION

In the current generation most of the countries do not have sufficient skilled man power specifically in agricultural sector and it affects the growth of developing countries. So it's a time to automate the sector to overcome this problem. In India there are 70% people dependent on agriculture. So we need to study agriculture. Innovative idea of our project is to automate the process of ploughing and sowing seeding such as sunflower, corn, groundnut and vegetables like beans, lady's finger, pumpkin and seed of wheat etc.

To reduce the human effort and increase the yield. The ploughing of firm and plantation of seeds is automatically done by using dc motor. The distance between the two seeds are controlled and varied by using microcontroller. When the robot reaches the end of the field we can change the direction with the help of remote switches. The whole process is controlled by microcontroller. Ploughing of firm and seed plantation is our day to day life is done by tractor in farms. But it requires more time & the man power shortage is faced continuously. The main requirement of automation is to reduce man power in our country; the buzzword in all industrial firms generally involves electrical, electronic component as well as mechanical part. Automation saves a lot of tedious manual work and speeds up the production processes.

Now a day we have lack of man power. Energy required for this machine is less as compared with tractors or any agricultural instrument pollution is also a big problem which is eliminated by using solar plate. a manual farm consumes more time & leads to more pollution. So it is a time to automate the process of ploughing and sowing of seed. Another is also need is to increase high speed of operation.

Development of a robot that can perform automates ploughing and seeding operation can be manually navigated

by the farmer and stabilize the humidity in the environment. Robotics and automation can play a significant role in enhancing agricultural production needs. Automation can be done by man in operations such as seeding and ploughing.

2. LITERATURE SURVEY

2.1. "Agricultural Robot for Automatic Ploughing and Seeding" 2015 IEEE International Conference on Technological Innovations in ICT (TIAR 2015) (Amrita Sneha.A, Abirami.E, Ankita.A, Mrs. R. Praveen, Mrs. R. Srimeena).

This paper strives to develop a robot capable of performing operations like automatic ploughing, seed dispensing. It also provides manual control when required and keeps tabs on the humidity with the help of humidity sensors. The main component here is the AVR At mega microcontroller that supervises the entire process. Initially the robot tills the entire field and proceeds to ploughing, simultaneously dispensing seeds side by side. On the field the robot operates on automated mode, but outside the field is strictly operated in manual mode.

2.2. "Design and Implementation of Seeding Agricultural Robot" (JIRAS) (P.Usha, V. Maheswari, Dr. V. Nandagopal)

In this paper, the robot system is used to develop the process of cultivating agricultural land without the use of man power. The aim of the paper is to reduce the man power, time and increase the productivity rate.

2.3. "Automated Farming Using Microcontroller and Sensors" (IJSRMS) ISSN: 23493371 (Abdullah Tanveer, Abhishek Choudhary, Divya Pal, Rajani Gupta, Farooq Husain)

Farming can be done using new technologies to yield higher growth of the crops. In this project we are going to check temperature, light, humidity and soil moisture. The paper here is all about automatic control features with latest electronics technology using microcontroller and GSM phone line. The project works automatically and hence reduces the manpower.

2.4. "IOT Based Smart Agriculture" IJARCCCE June 2016 (Nikesh Gondchawar1, Prof. Dr. R. S. Kawitkar2)

In this paper a project model for agriculture robot is describe the newer scenario of decreasing water tables, drying up of rivers and tanks, unpredictable environment present an urgent need of proper utilization of water. To

cope up with this use of temperature and moisture sensor at suitable locations for monitoring of crops is implemented in an algorithm developed with threshold values of temperature and soil moisture can be programmed into a microcontroller-based gateway to control water quantity. The system can be powered by photovoltaic panels and can have a duplex communication link based on a cellular internet interface that allows data inspection and irrigation scheduling to be programmed through a web page. The technological development in wireless sensor networks made it possible to use in monitoring and control of greenhouse parameter in precision agriculture. After the research in the agricultural field, researchers found that the yield of agriculture is decreasing day by day. However, use of technology in the field of agriculture plays important role in increasing the production as well as in reducing the extra man power efforts. Some of the research attempts are done for betterment of farmers which provides the systems that use technologies helpful for increasing the agricultural yield.

3. BLOCK DIAGRAM

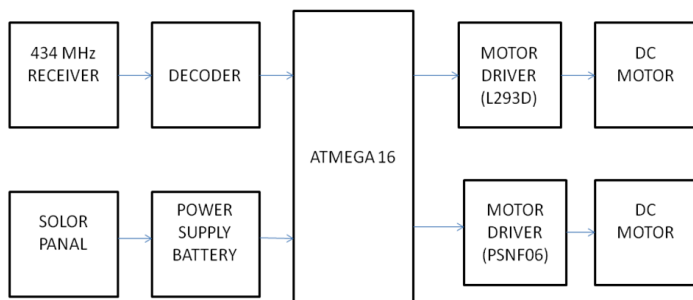

Figure 1: Shows Basic Block Diagram Of Agricultural Robot

3.1 Avr Microcontroller

The atmega16 is a low power CMOS 8-bit microcontroller based on the AVR enhanced RISC architecture. By executing powerful instruction in a single clock cycle, the atmega16 achieves outputs approaching 1 MIPS per MHz allowing the system designed to optimize power consumption versus processing speed.



3.2 Rf Transmitter

Depending on the key pressed the controller encodes the data to the RF transmitter where the data will be modulated and transmitted .the RF transmitter is a three pin module in

which the first is the input that is connected to the microcontroller and the next two pins are VCC and ground respectively. This is an inbuilt module which is available in the market.

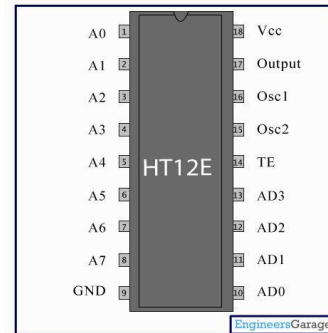

3.3 Rf Receiver

As explained in the block diagram the RF receiver will be demodulating the received signal. The demodulated output will be the actual data signal that is original signal that is transmitted from the transmitter the RF receiver consist of three pins. First is ground, second is the output, which is connected to the microcontroller and the third is the VCC.

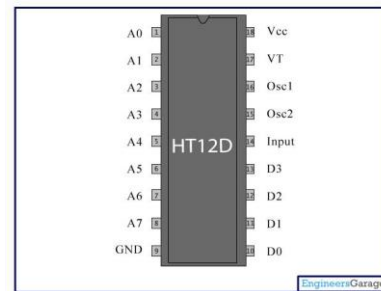

3.4 DC Motor

Permanent magnet dc motor responds to both voltage and current. The steady state voltage across a motor determines the motor's running speed and the current through is armature winding determines the torque. Apply a voltage and the motor will start running in one direction; reverse the polarity and direction will be reversed. If you apply a load to the motor shaft, it will draw more current. If the power supply does not able to provide enough current, the voltage will drop the speed of the motor will be reduced. However if the power supply can maintain voltage while supplying the current, the motor will run at the same speed.



3.5 Remote

The remote controller transmitter a small handheld unit with four keys which works on 12v battery to give good range of operation. When key is pressed the IC is connected to power supply battery and it starts transmitting packets at 121 MHz frequency consisting of its ID and data byte which totally indicates which key was pressed. This information is used in remote control application

4. SYSTEM DESIGN

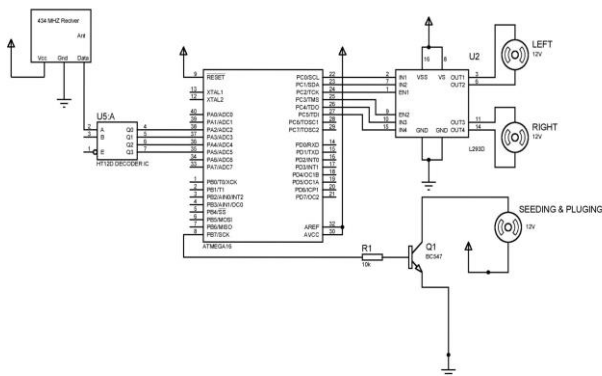

Figure 2: Shows circuit diagram of agriculture robot

Block diagram and circuit diagram of agricultural robot as shown above. The robot contains components At mega 16 microcontroller, RF transmitter, RF receiver, dc motor, remote, battery, solar panel. It works as per flow shown in block diagram. Remote provides operating command to a transmitter, via RF signal the transmitter transmit the signal to robot. This signal received by receiver section of the robot and it physically operated. DC motor will actuate and the motor get revolution as per receiving command. Wheels are connected through DC motors, so that the motors get revolution the wheels are also rotated as given order reverse, forward, left and right with respective button present on remote. Firstly burn the code into microcontroller IC using flash magic and switch on the power supply. Now send the command to the receiver using transmitter and receiver receive these commands after that robot perform the ploughing and seeding operation as per the given commands. Teeth are up and down during ploughing operation and hopper is close and open during seeding operation.

5. FUTURE WORK

In this paper author tried to present related work of agricultural robot as labour problem can be reduced as compared to the manual and tractor based sowing time, energy required for this robot machine is less. At the same time by using solar energy environment pollution can also be reduced. Rests of modules are pending, such as flow chart, programming, graph plots and output result of the agricultural robot. It will publish in next paper.

REFERENCES

- 1) "Automated Farming Using Microcontroller and Sensors", International Journal of Scientific Research and Management Studies (IJSRMS), 2015 Abdullah Tanveer, Abhish Choudhary, Divya Pal.
- 2) "Automated Irrigation System by Using Arm Processor", International Journal of Scientific Research Engineering & Technology (IJSRET), 2014 Gayatri Londhe, Prof. S. G. Galande.
- 3) "Automatic Seed Plantation Robot", (IJESC), 2016 Prashant G. Salunkhe, Sahil Y. Shaikh, Mayur S. Dhable, Danis I. Sayyad.
- 4) "Agricultural Robot for Automatic Ploughing and Seeding", 2015 IEEE (TIAR 2015), Amrita Sneha.A, Ankita .A, Abirami.E.
- 5) "IOT Based Smart Agriculture", International Journal of Advanced Research in Computer and Communication Engineering, 2016 Nikesh Gondchawar, Prof. Dr. R. S. Kawitkar
- 6) "Design and Implementation of Seeding Agricultural Robot", (JIRAS) (P.Usha, Dr. V. Nandagopal)
- 7) "Multi Purpose Agricultural Robot", International Research Journal of Engineering Research (IRJER), 2016 Nitin P V, Shivaprakash S.
- 8) "Development of Multipurpose Agriculture Machine", International Journal of Advanced Engineering and Research Development, 2017 Narendra Patel, Himanshu Patel, Utsav Patel.
- 9) "Seed Sowing Robot", International Journal of Computer Science Trends and Technology (IJCST), 2017 Abdulrahman, Mangesh Koli, Umesh Kori, Ahmadakbar.
- 10) "Solar Operated Automatic Seed Sowing Machine", International Advanced Research Journal of Advanced Agricultural Sciences and Technology, 2015 Shwetha S. and Shreeharsha G. H.