

Smart Wireless Surveillance BOT with video monitoring and object avoiding facility

Sonu kumar¹, Suraj kumar², Shruti shankar³, Sakshi saxena⁴

^{1,2,3,4}Student, Dept. of EC, IMS Engineering College, Ghaziabad, UP, India

Abstract – Robots nowadays plays a major role not only in the daily industrial operations but are extensively used in the areas of defense, industries, medical and home applications. They can carry out different risky jobs that cannot be done by a human. This paper presents Surveillance robot that has its importance in defense and military purpose. It proposes one of the ways in which robots can be used in future to perform difficult tasks by the use of various sensors like LDR sensor for night vision, fire detection sensor with pump motor to extinguish the fire, IR sensors for pathfinding and obstacle avoidance, moisture sensor. This paper, however, presents only the use of object avoidance facility and a camera mounted on the top of it to provide continuous visual monitoring. In the similar ways, various other facilities can also be incorporated into it by interfacing the corresponding sensors.

Key Words: 8051 microcontroller, wireless, camera, Bluetooth. The robotic arm, object avoidance.

1. Introduction

Our project aims to provide a robotic vehicle equipped with a wireless camera for remote monitoring/spying purposes that can also be replaced with a night vision camera. This camera allows the transmitting of real-time video even in hazardous environments where a human cannot reach. Whatever is recorded by the camera can be viewed in PC for reference and further analysis

The 8051 microcontroller now operates the movement motor through a driver IC. The robotic vehicle can be easily operated from any Android device. It provides a good user interface for handling the vehicle. The Android device can operate the vehicle at a good Bluetooth communication range. The Bluetooth receiver at the vehicle is used to transmit control movement data from app to vehicle. The night vision camera can also be mounted on robot allows for efficient spying even in darkest areas using infrared lighting.

Further the project can be enhanced using WiFi technology. Using this technology we can control the robotic vehicle by using a web server. This technology has an advantage over long communication range as compared to Bluetooth technology.

2. Application and future scope

The following are the applications of this smart bot-

- Pathfinder applications areas inaccessible to humans like mines and damaged buildings.
- Dimensional tracking of the area under surveillance and patrolling.
- The self-guided vehicle for the industrial material transportation system in large workspace such as hospitals, container ports etc.

The following points elaborate the future scope of this bot-

- ✓ In this world of technological advancement and the need to protect precious human lives, the concept of surveillance under supervision will always be 'THE NEED OF THE HOUR'. This robotic platform for surveillance purpose can be extended to many applications where human life would be at stake.
- ✓ The concept of surveillance can be extended to 'Land Mine' detection, just by incorporating a metal detector and high-resolution camera along with the robot chassis developed.
- ✓ In case of fire accident or smoke detection, the robot can be fitted with the respective sensor units, so that the information regarding the hazardous situation can be made available for the people.
- ✓ The efficiency of the robotic movement can further be enhanced by using efficient intelligent control algorithms and servo motors.

3. Hardware used

- 8051 microcontroller
- L293D Motor driver IC
- Bluetooth HC-05 Module
- Camera
- Ultrasonic sensor
- Robotic Arm
- DC Motors

4. Software/language used

- Keil Compiler
- Embedded c or assembly language programming

5. Block diagram

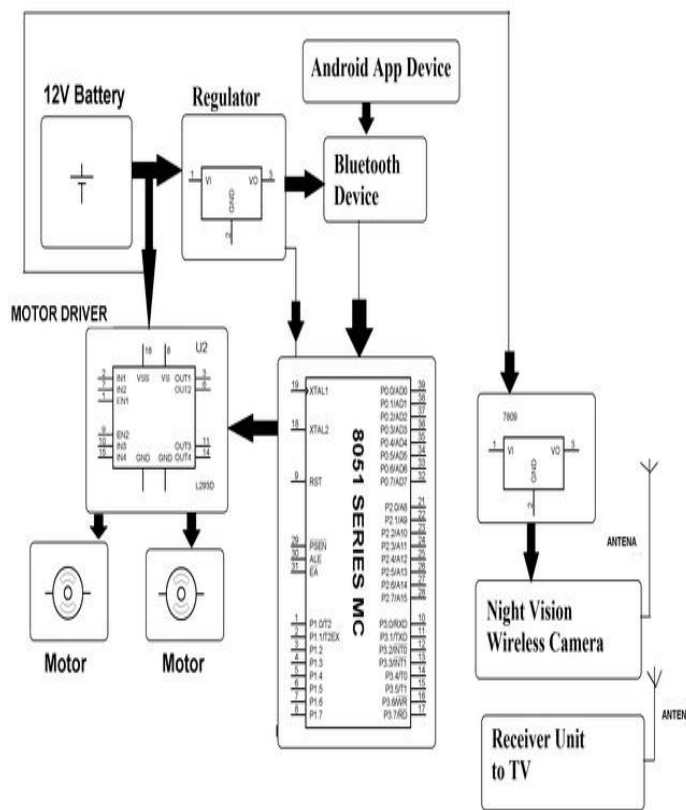
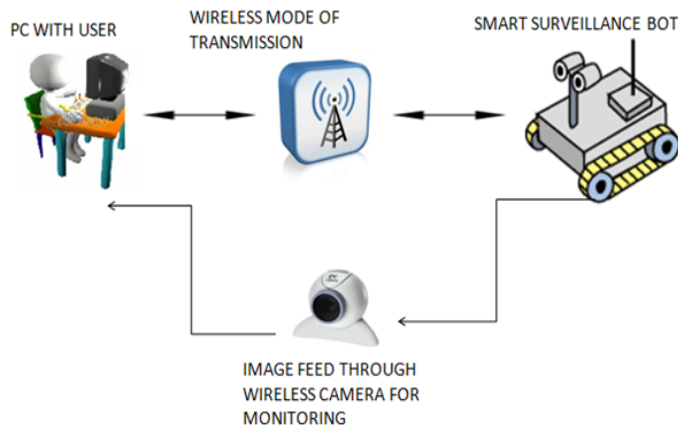

Fig-1: features to be incorporated in robot

6. Hardware components description

6.1 8051 series microcontroller

The 8051 microcontroller is extensively used in making various projects of the Embedded system. The main features of 8051 microcontrollers are:-

- 8051 microcontroller is an 8-bit microcontroller. It has 8-bit data bus. With the help of 8-bit data, bus microcontroller will process 8-bit data at a time

- It has 16-bit address lines divided into low order address bus and high order address bus.
- It requires 12 MHz clock input frequency for its operation.
- It has 128 bytes on-chip data memory and 4 kb of on-chip program memory.
- It has two timers or counter of 16 bit to perform delay or counting operation.
- It has 8-bit accumulator register mainly used in Arithmetic and logical operation, 8-bit register and eight 8 bit registers are R0, R1, R2, R3, R4, R5, R6, R7.
- In addition to 8-bit registers, the microcontroller will have two 16 bit registers i.e, program counter register and data pointer register denoted by DPTR.
- It has 8-bit program status word register also called flag register.
- It has 8-bit stack pointer register.(Bank 1)
- It has four 8 bit ports-P0, P1, P2, P3

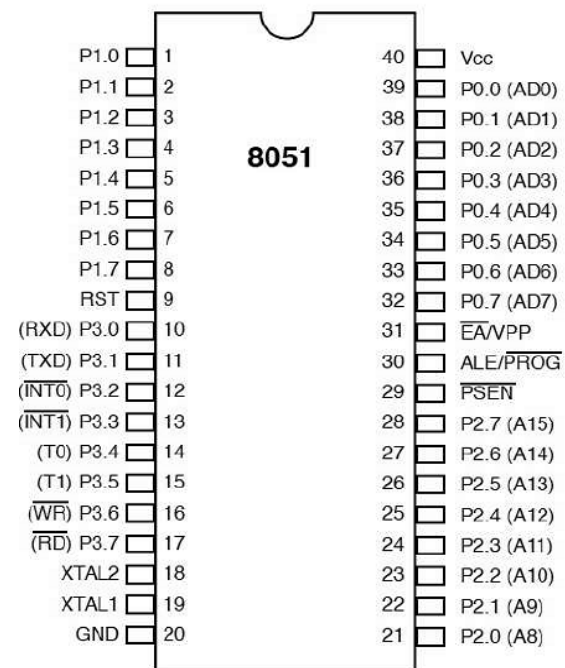

Fig-2: 8051 pin diagram

6.2 L293D motor driver IC

The L293D motor driver IC is used for controlling the dc motors of the robot. Thus making the robot to move around effectively in any direction. It consists of two NPN and PNP transistors each forming the two H-bridges. Using a single we can control two dc motors.

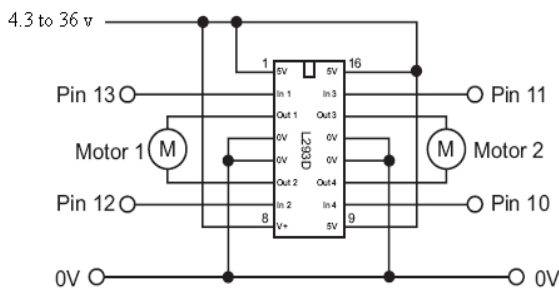

Fig -3: pin diagram of L293D motor driver IC

6.3 Bluetooth HC 05 module

The HC-05 module is an easy to use Bluetooth SPP (Serial Port Protocol) module that is designed for seamless wireless serial connection setup. The HC-05 Bluetooth Module can be used in either Master or Slave configuration, making it a perfect solution for carrying out wireless communication application. This serial port Bluetooth module is used to control the robotic movement by the controls provided on the android app.

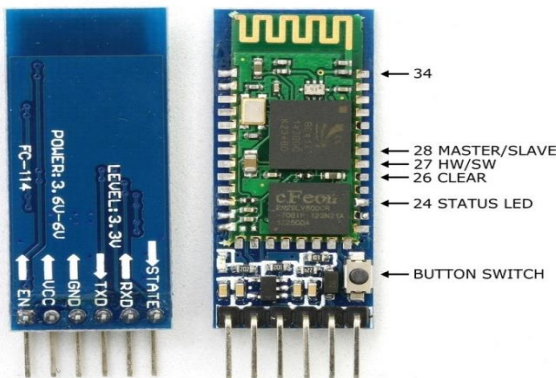

Fig-4: view of HC05 Bluetooth module

6.4 Camera

In this project, we have used a wireless camera for providing a continuous video feedback to the laptop or desktop that proves to be effective for 24*7 monitoring and surveillance of the area under view. However for the reduction of cost a very simple wireless camera mounted on the top of robot is used but it can be replaced with high resolutions or megapixels of camera to enhance the video quality and employing other features like night vision or using digital image processing for carrying out very specialized and highly sophisticated information gathering like targeting and eliminating the enemies in a war zone, fire detection etc.... The module was initially designed for surveillance purposes. The display of the camera can be seen on laptop or desktop by installing the application of the camera.

6.5 Ultrasonic sensor

The Ultrasonic Sensor sends out a high-frequency sound pulse and then times how long it takes for the echo of the sound to reflect back. This sensor is used here to provide the object avoidance facility to the robot. The Ultrasonic Sensor sends out a high-frequency sound pulse and then times how long it takes for the echo of the sound to reflect back. The sensor has 2 openings on its front. One opening transmits ultrasonic waves, (like a tiny speaker), the other receives them, (like a tiny microphone). The speed of sound is approximately 341 meters (1100 feet) per second in air. The ultrasonic sensor uses this information along with the time difference between sending and receiving the sound pulse to determine the distance to an object.



- Vcc- Connects to 5V of positive voltage for power
- Trig- A pulse is sent here for the sensor to go into ranging mode for object detection
- Echo- The echo sends a signal back if an object has been detected or not. If a signal is returned, an object has been detected. If not, no object has been detected.
- GND- Completes electrical pathway of the power.

Fig-5: view of HC05 Bluetooth module

7. CONCLUSIONS

This system is very useful in war, terrorism and sensitive areas. It can also be used to operate in jungles and other environments humans cannot possibly enter. The vehicle can be controlled remotely by an Android device for easy operation. It uses android application commands to move in front, back and left right directions. The vehicle consists of receivers interfaced to an 8051 microcontroller. On receiving a command from the receiver.

In this project, we analyzed the solutions currently available for the implementation of IoT. By implementing this project we will step towards a new era of bots with upcoming high-speed 5G and with it the introduction of IOT. It can automatically monitor the surveillance area & send the information to anyplace and anywhere. The technologies which are used in the proposed system are good enough to ensure the practical and perfect for monitoring and management for green environment.

9. ACKNOWLEDGEMENT

Our project would not have been possible without the guidance of Prof. Abhishek Sharma (Associate professor, ECE department, IMS Engineering College, UP, India) and other

faculties, lab assistants of ECE department, IMSEC for their technical support and constant supervision which contributed immensely to project development. I also thank for their guidance which has a remarkable force that enabled me to successfully complete the project program. They helped and coached me during my project by giving me feedback and tips on how to handle and approach situations. Last but not least, special thanks to all my friends for sharing their experiences, time and commitment especially during finishing of the project.

8. REFERENCES

- [1] <http://nevonprojects.com/android-controlled-based-spy-robot-with-night-vision-camera-project>.
- [2] <https://www.elprocus.com/pin-diagram-of-8051-microcontroller>.
- [3] <https://www.instructables.com>.
- [4] <http://nevonprojects.com/8051-project>.