

OVERVOLTAGE, UNDERVOLTAGE PROTECTION OF ELECTRICAL EQUIPMENT

Gorkshanath Bhosale¹, Aakash Vakhare², Abhishek Kaystha³, Amol Aher⁴
Vishal Pansare⁵

^{1,2,3,4} Student, Electrical Engineering, MET's Institute of Engineering, Adgaon, Nashik

⁵Asst Professor, MET's Institute of Engineering, Adgaon, Nashik

Abstract - The purpose of this project is trip the relay according to the variations in supply voltage for protecting electrical household as well as industrial equipment in case of overvoltage and under voltage. The electronic devices are very sensitive towards voltage variation, as voltage variation comes in supply the electronic equipment get easily damaged. In that condition it requires an additional protecting mechanism to protect the equipment as a load. According voltage comparator integrated circuits the decision of tripping of relay mechanism get performed, as voltage varies above or below the set value. The main advantage of this relay based mechanism is that it also protects three-phase appliances from single phasing and fluctuation of voltage in ac voltage waveform. In future their might be addition of earth fault detection and protection, automatic starting protection circuitry.

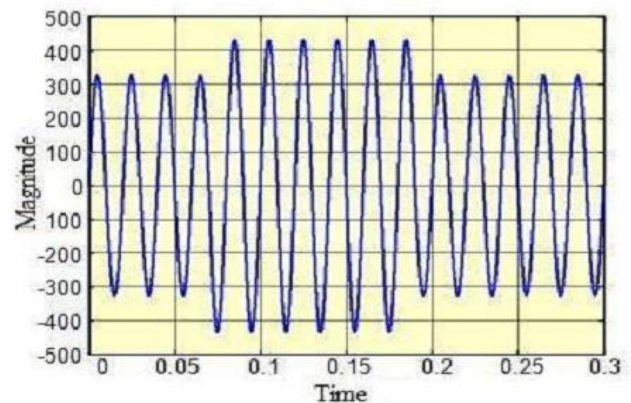

Fig-1: waveform for overvoltage

Key Words: overvoltage and under voltage protection, voltage comparator circuitry, tripping mechanism of relay.

1. Introduction

Recent year one major problem in industry as well as house hold is sudden over voltage or under voltage which results damage the equipment. Electronic based load increases day by day in household as well as industrial application and they are very sensitive to voltage variation. In this project, focus the protect the equipment in case of over voltage or under voltage and the study of over voltage and under voltage, various power quality issues.

2. Power quality issues:

2.1 Overvoltage:

An overvoltage is an increase in the rms value of ac voltage greater than 110 percent or 0.11pu at the power frequency for a duration longer than 1 min. over voltages are usually the result of load switching (e.g., switching off a large load or energizing a capacitor bank). The over voltages result because either the system is too weak for the desired voltage regulation or voltage controls are inadequate. Incorrect tap settings on transformers can also result in system over voltages.

2.1.1 Causes of over voltages:

Overvoltage are less common than under voltage but they also arise due to system faults. Overvoltage can occur due to single line to ground fault, which in turn will raise the voltage of the other phases. It can also cause due to disconnection of heavy industrial loads or switching on the capacitor banks. This is generally due to ungrounded or floating ground delta systems, where a change in ground reference would give voltage rise to the ungrounded system. Causes of overvoltage are mainly due to energization of capacitor bank. It can also be generated by sudden load deduction. Due to the disconnection of load there is a sudden reduction of current, which will give rise the voltage, where L is the inductance of the line. The effects of overvoltage are more severe and destructive. It may cause the electrical equipment to fail, due to overheating caused by high voltage. Also electronic and other sensitive equipment are prone to malfunction.

According to IEEE 1159 Classification of overvoltage

Types of Voltage	Duration	Magnitude
Instantaneous	0.5 – 30 cycles	1.1 – 1.8 pu.
Momentary	30 cycles – 3 sec	1.1 – 1.4 pu.
Temporary	3 sec – 1 min	1.1 – 1.2 pu.

Table-1: Classification of overvoltage

2.1.2 Some more causes of Overvoltage are given below

- Loss of a Secondary Neutral (When the neutral wire is broken by falling branches).
- Ferroresonance (is a special form of series resonance between the magnetizing reactance of a transformer and the system capacitance (charging capacitors)).

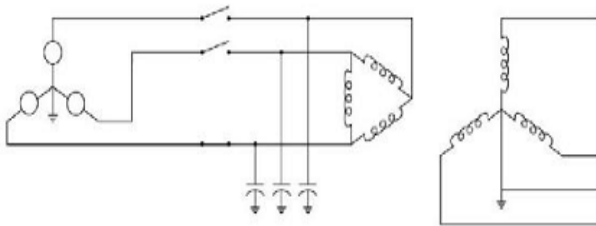

Fig-2: Cause of overvoltage

- Accidental Contact to High-Voltage Circuits
- Over voltages Due to Poor Voltage Regulation

2.2 Under voltage:

An under voltage is a decrease in the RMS value ac voltage to less than 90 percent or 0.90pu at the power frequency for a time period longer than 1 min. Under voltages are the result of switching events that are the opposite of the events that cause over voltage.

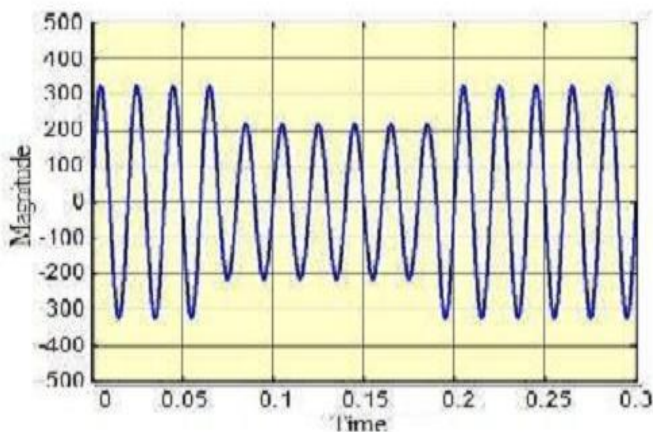

Fig-3: Waveform for under voltage

Under voltages are the most common power disturbance whose effect is quite severe especially in industrial and large commercial customers such as the damage of the sensitivity equipment's and loss of daily productions and finances. The examples of the sensitive equipment's are Programmable Logic Controller (PLC), Adjustable Speed Drive (ASD) and Chiller control. Under voltage at the equipment terminal can be due to a short circuit fault hundreds of kilometers away in the transmission system

2.2.1 Causes of under voltages:

- Closing and Opening of Circuit Breakers
- Due to Fault
- Due to Motor Starting
- Due to Transformer Energizing
- Equipment Failure
- Bad Weather and Pollution (Lightning strikes, Flash over, etc.)
- Construction Activity(damage to underground Cables

3. Method Used For Protection

The aim of our circuit is to protect the load during under-voltage and over current conditions by controlling the relay tripping coil using a LM324 comparator. The comparator will compare the supply voltage with desired preset voltage and will trip the relay coil if the voltage drops below the desired preset value. The relay coil will also trip if the. The under voltage and over current protecting device is shown in the block diagram below

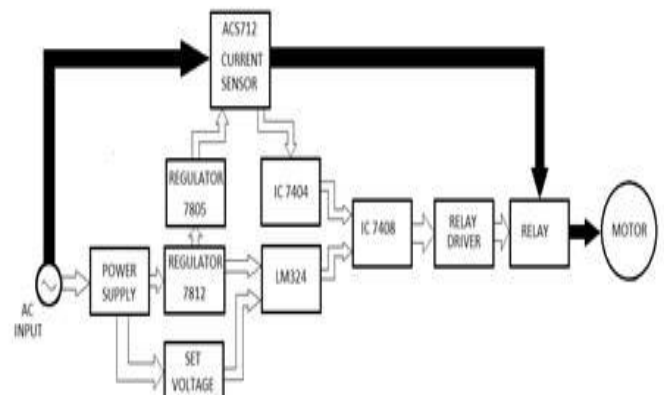

Fig-4: Method Used For Protection

4. Equipment use in Circuit:

- Transformer 12v
- Bridge wave rectifier
- Capacitors-480, 0.1micro farads
- Regulator IC 7812
- Potentiometer-50k
- Zener diode-6.8v, 6.0v
- Resistances -10k, 5k, 1k

- IC LM324
- Led
- Diode of IN4007
- Relay
- Load

5. Description of above equipment:

5.1 Transformer:

A 230 by 12 volt single phase transformer is used for power supply of voltage comparator circuit.

5.2 Bridge wave rectifier:

Full wave rectifier with the four diode with capacitor as filter is used for bridge rectifier circuit.

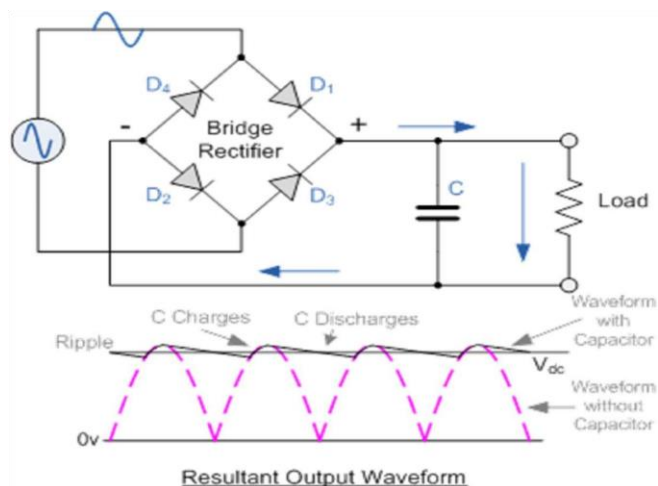

Fig-5: Bridge wave rectifier

When as supply given to it, at positive half cycle D1 and D3 is in forward bias and start conduction at that time diode D2 and D4 are in reverse bias and block supply through them but at negative half cycle the exactly reverse operation occurs. Diode D1 and D3 goes in reverse bias and block the conduction at that time diode D2 and D4 are in forward bias and start conduction.

5.3 Regulator IC 7812:

The voltage regulator IC gives +12 volts, after the capacitor it is being used in power supply. In IC 7812, the 78 denotes positive this is a 9V power supply which will work even on power failure.

5.4 Potentiometer-50k:

Potentiometer is used as the variable voltage driver for adjusting the preset value. It is class of variable resistor. We can vary voltage by using variable resistance pot also

called as wiper. The main part is a resistive strip inside it through which we can able to adjust the amount of resistance/voltage to pass in a circuit through it.

5.5 LM324:

LM324 is a 14 pin IC. Having four op amp in it, hence also called quadruple op amp IC. Op amps can be used as amplifiers, comparators, oscillators, rectifiers etc. The conventional op-amp applications can be more easily implemented with LM324. Here op amps used as voltage comparator for comparing two voltage levels.

5.5.1 Pin Diagram

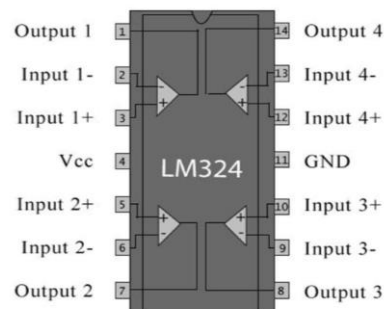

Fig -6: Pin Diagram

5.6 Relays:

A relay is an electrically operated switch. Many relays use an electromagnet to operate a switching mechanism mechanically, but other operating principles are also used. Relays are used where it is necessary to control a circuit by a low-power signal (with complete electrical isolation between control and controlled circuits), or where several circuits must be controlled by one signal

5.7 Zener diode:

Zener diode is the diode which can allow current flow both from its anode to its cathode and vice versa zener diode can also its break down region reliably. In this project zener diode is used for take constant voltage i.e DC fixed voltage as a preset value.

6. Circuit diagram:

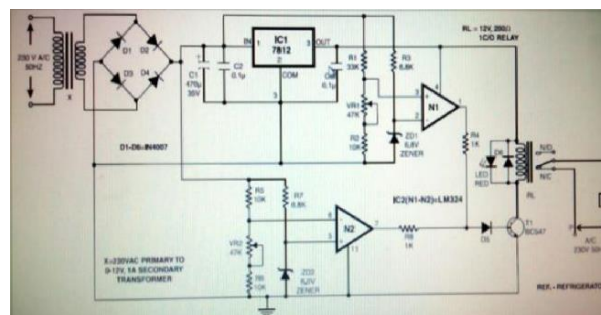

Fig -7: Circuit Diagram

7. Working:

If 220VAC input is applied circuit step-down transformer will reduce voltage to 12volt.Using Bridge rectifier IC 12volt DC output is obtained.

Using IC LM7812 we get regulator DC supply Regulator Input at pin 1 and 2 and from pin 3 and 4 output is taken. IC LM324 serve as heart of protection circuit. It has 4 comparator in it.4th pin is connected to Vcc and 11th pin is grounded. Two zener diode of 6volt and 6.8volt are used.6.8 volt zener diode is connected to 2nd pin of ICLM324 (comparator no.1).6 volt zener diode is connected to 5th pin of ICLM324.

IC2/1 of comparator IC used for overvoltage Protection.IC2/2 of comparator IC used for under voltage protection. When supply voltage raise beyond or fall rated voltage Proportional DC voltage will change and relay driver IC will command to relay driver to relay and relay will get tripped.

8. Possible additional circuits:

- Earth fault detection
- Automatic starting protection

9. Applications:

- Industrial machinery
- House hold items like TV , refrigerator
- Agriculture motors
- Water pumps
- Microwave oven

10. Conclusion

From above discussion it has cleared that of under voltage and overvoltage problem are very common and can create problem for consumer good and industrial application. So system should be protected by certain protection scheme. So here system modeled using comparator and relay to disconnect supply when any overvoltage and under voltage problem occurs.

Reference:

- G. Yaleinkaya, M. H. J. Bollen and P.A. Crossley (1999), "Characterization of voltage sags in industrial distribution systems", IEEE transactions on industry applications, vol.34, no. 4, pp. 682-688, July/August.
- "IEEE Recommended Practice for Monitoring Electric Power Quality," IEEE Std. 1159-1995, June 1995.

- G.A. Taylor, A.B. Burden (1997), "Wide Area Power Quality - Decision Processes and Options for Sensitive Users", Proceedings of the 14th International Conference and Exhibition on Electricity Distribution (CIRED'97), pp. 2.30.1-2.30.5, Birmingham, UK, June.
- Girish Chandra Thakur, Kumar Shantanu Kaushal, Manish Ranjan, sandip kumar gupta. "Implementation of Single Phasing, Over Voltage, Under Voltage, Protection of Three Phase Appliances without Using Microcontroller", Int. Journal of Engineering Research and Applications, ISSN :2248-9622, Vol. 5, Issue 5, (Part -6), pp.110-115, May 2015.
- Manish Paul, Barnali Talukdar and Banani Baishya, "Simulation of Overvoltage and Undervoltage Protection in PSIM", International Journal of Engineering Research & Technology (IJERT) ISSN: 2278-0181, pp.1005-1008, Vol. 3 Issue 11, November-2014.