

POWER GENERATION USING PZT FOR AUTO STREET LIGHTNING SYSTEM

Ms. Priyanka V. Rathod¹, Ms. Bhagyashree K. Sarode², Prof. K. P. Mahure³

^{1,2}UG Scholar, Electrical Engineering (E&P), DESCOET, Dhamangaon (Rly.), Maharashtra, India,

³Assistant Professor, Electrical Engineering (E&P), DESCOET, Dhamangaon (Rly.), Maharashtra, India,

Abstract - Energy consumption is an indicator of the development of the universe. The modern world needs a large amount of electricity to meet current demand, while the resources of conventional energy sources are steadily declining in response to high energy consumption. Therefore, alternative energy sources are required not only to bridge the big gap between electricity supply and demand, but also to be clean, environmentally friendly and sustainable. The work of this seminar is based on the piezoelectric effect in which certain materials have the ability to accumulate an electric charge by applying pressure and tension. This seminar focused on public lighting applications for transport facilities using this energy. When roads or vehicle tires are designed with piezoelectric technology, the energy produced by the pressure of moving vehicles is detected by piezoelectric sensors and converted titanate titanium charged titanium electric charge as a piezoelectric transducer (PZT), then storing energy and used as a source of energy generation. This energy source can be used for automatic street lighting as a source of the power generating unit on the road.

Key Words: power consumption, full wave rectifier bridge, lead zirconium titanate, piezoelectric effect, street lamp, vehicle motion detection.

1. INTRODUCTION

In general, the street lamps light up all night and go out during the day. But during the night, the street lamps are not necessary if there is no traffic. Saving this energy is a very important factor these days as energy resources are reduced day by day. The alternatives for natural resources are very limited and our next generations can face many problems due to the lack of these natural resources. This article describes the street lighting circuit when it detects vehicle movement and remains off after a fixed time that implements the piezoelectric power generation paths. The term or renewable energy such as solar panels or wind turbines is a method of producing electricity using energy around the environment of the sun and wind, for example. However, the energy formed by different vibrating machines, moving objects or any other source of mechanical energy is not captured. As an effective method to use this loss, the piezoelectric material is used to absorb wasted mechanical energy and convert it into electrical energy. The principle of piezoelectricity is behind the crystals. There are different types of natural crystals, present on the surface or deep in the ground, which can be used today to apply the piezoelectric effect, such as light quartz and amazonite.

The electricity generated by a piezo is rather small and in practice is not useful, so we have a series of piezoelectric transducers. Taking into account the high number of piezoelectric matrices and the high pressure applied by heavy vehicles, the generated electricity increases. The electricity generated by these transducers is rectified and further regulated by the use of the energy capture circuit. Now, this instantaneous energy is not used directly, but the electricity generated during the day is stored in the batteries. Therefore, the accumulated amount of electricity stored in the battery is high enough to feed street lamps. There is also an automation circuit that controls the street lamps, both day and night, and also changes the intensity of the street lamps depending on the density of the vehicles at any time. The street lamps will be switched off during the day and will automatically switch on at night. At night, the street lights shine with high density if there is a good amount of traffic, otherwise the street lamps shine at low intensity, further energy savings. This technology is based on a principle called piezoelectric effect.

The connection of PZT can broadly be classified as follows:

- 1) Series connection
- 2) Parallel connection

2. PIEZOELECTRIC EFFECTS

Piezoelectricity is the electric charge that accumulates in some solid materials in response to applied mechanical stresses. The word piezoelectricity means electricity that comes from latent pressure and heat. It comes from the Greek piezein, which means to press or crush, and electron, which means amber, an ancient source of electric charge. The French physicists Jacques and Pierre Curie discovered piezoelectricity in 1880. The piezoelectric effect is due to the linear electromechanical interaction between mechanical and electrical states in crystalline materials without inversion symmetry.

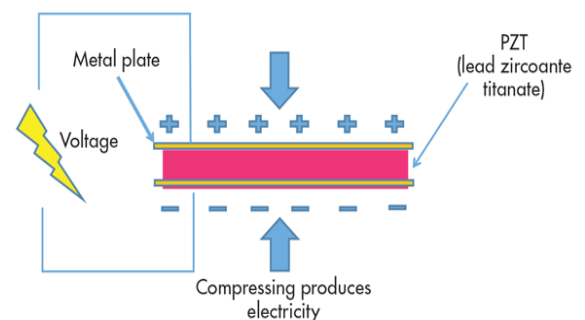

Fig. 2: Piezoelectric Effect

2.1: ROLE OF PIEZOELECTRIC MATERIALS IN POWER GENERATION

Piezoelectric ceramics belong to the family of ferroelectric materials. Ferroelectric materials are crystals that are polar without an applied electric field. The piezoelectric effect is common in piezoelectric ceramics such as pbtio3, pbzro3, PVDF and PZT. The important component of the project is the piezoelectric material. The right choice of piezoelectric material is of the utmost importance. For this, an analysis was performed on the 2 most commonly available piezoelectric materials, PZT and PVDF, to determine the most suitable material.

The piezo transducer material under test is positioned on a piezoelectric force sensor. The voltmeters are connected through both to measure the voltages and an ammeter is connected to measure the current. When variable forces are applied to the piezoelectric material, various voltage readings corresponding to the force are displayed. For each voltage reading through the force sensor, various voltage and current readings of the piezoelectric test material are detected.

2.2: PZT CONNECTION STUDY

The type of connection that provides the appreciable voltage and current required, three PZTs are connected in series.

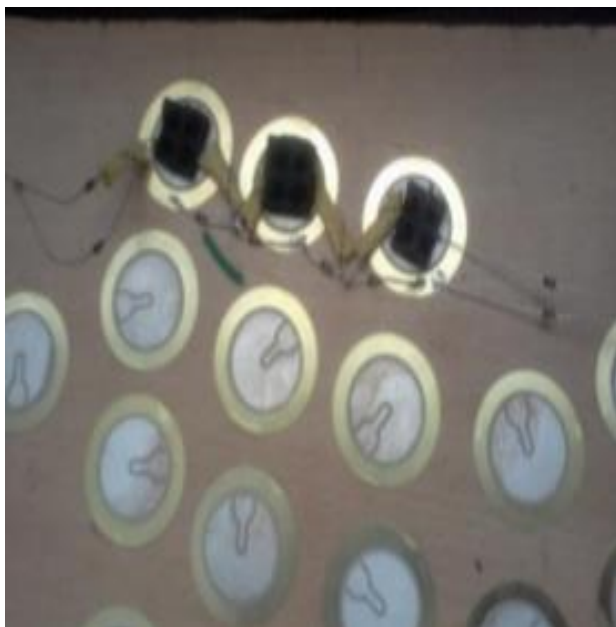

Fig. 2.2: PZT in series connection

Fig. 2.2 Demonstration of PZT in series connection A force sensor and a voltmeter are connected to this standard combination. When variable forces are applied to this connection, the corresponding voltages are detected. The voltage generated through the series connection and the current is also measured. In the same way, the connections are made for parallel and parallel serial connections and the graphs are as in chart 1.

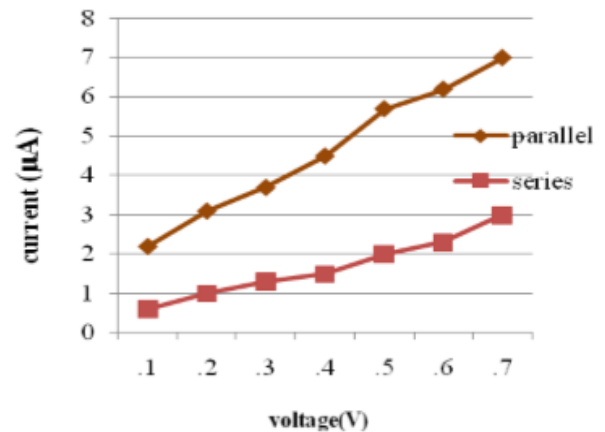

Chart 1: V-I graph of parallel and series connection

This emulation of the piezoelectric transducer was performed with the equivalent of Thevenin previously validated after comparative tests with a piezoelectric. For this, the piezoelectric transducer was subjected to vibrations of 20 Hz and the output voltages were measured after connecting several resistive loads.

This process was repeated by changing the amplitudes of the applied vibrations. As can be seen in figure (a), the differences between the tensions obtained using the Thevenin Equivalent and those generated by the piezoelectric make it possible.

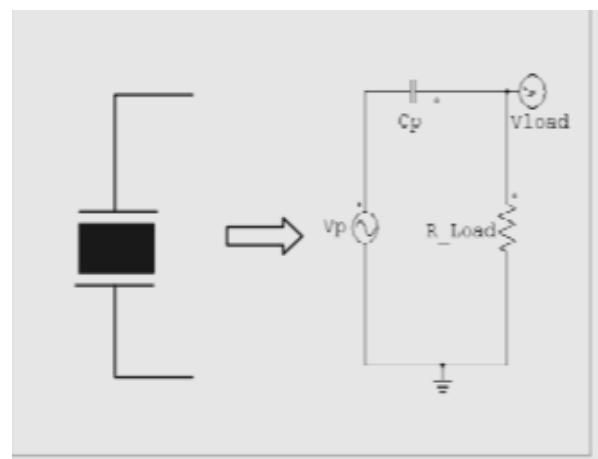

Fig. (a): Piezoelectric symbol and its Thevenin equivalent.

Approach this research using the equivalent of Thevenin in a versatile way with sufficient approximation to the current process. The goal was to measure the profitability and efficiency of each of these circuits to be grouped together to work in parallel.

To this end, each circuit is connected to another identical circuit to form groups of two, three and four circuits that work in parallel, simulating several piezo ready at the same time. Again, each of the circuits received a peak sinusoidal signal of 20 V peak with a frequency of 20 Hz and the output of each circuit, a 10 mF capacitor from 0 V to 1.8 V was charged.

2.3: GENERAL DESCRIPTION OF THE ENERGY COLLECTION

The capture of energy, or the elimination of energy, is defined as the extraction of energy from the environment. Environmental energy converted into electricity can be like light, temperature gradients, kinetic energy or radio frequency (RF).

Mechanical vibrations are present in a series of useful positions with the advantage of not limiting the size and the need for light. There are three main transducer mechanisms for the task of converting mechanical energy. Solar energy provides the most familiar form of energy harvesting. Based on the photovoltaic effect, this technology can produce up to 10 \mW / cm² on a sunny day. However, photovoltaic solar panels are not suitable for places where light is not available or it is not possible to place a panel facing the sun.

In electric energy: electromagnetic (EM), electrostatics (ES) and piezoelectric (PZ).

- 1. Electromagnetic:** According to Faraday induction law, electromagnetic coils produce higher power, varying available are 20 uW to 200 mW [1], but they are usually larger in size and output voltages generated are low
- 2. Electrostatic:** Electrostatic devices using a variable capacitor to collect energy [1] produce energy levels (from 10 to 40 uW) much lower than electromagnetic devices and to operate require an external power source, such as a battery.
- 3. Piezoelectric:** Piezoelectric transducers are suitable for miniaturization, voltages generate appropriate output up to 20V, but with very high output impedance, which means the output current levels in the microampere range providing power levels up to several tens of milliwatts.

2.3.1: ENERGY COLLECTION DESIGNED SYSTEM

A typical energy collection system consists of several subsystems, including power transducers, energy management hardware, and energy storage to provide power to the electronic application based on adequate and stable voltage specifications. A typical energy collection system is shown in Fig. 2.2.1.

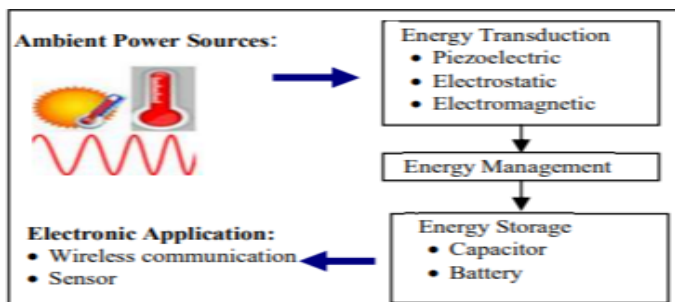

Fig. 2.3.1: Generic Energy Harvester System Schematic

The simplest circuit for energy management is the diode rectifier bridge, but its efficiency depends largely on the electrical load

2.4: CIRCUIT DESCRIPTION

2.4.1: BLOCK DIAGRAM OF POWER GENERATION USING PZT

When the vehicle is pressurized in the piezoelectric plates, a reasonable voltage is produced which is proportional to the displacement of the piezoelectric crystal materials. The high frequency AC signal is converted to DC for application purposes. The increase in the number of piezoelectric plates causes a higher voltage generated. The charging circuit charges a 12 V battery, where the inverter circuit converts this DC voltage to alternating current. The dark detection circuit is used to detect the night and change the inverter so that the street lighting turns on. Figure 2.4.1 shows that the whole system is represented by a block diagram.

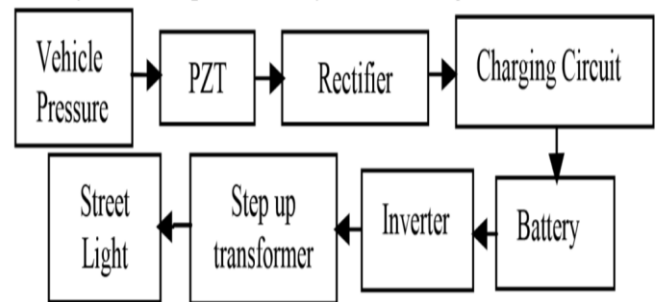

Fig. 2.4.1: Block diagram of power generation using PZT

2.5: PZT Work

The piezoelectric material converts the applied pressure into electrical energy. The source of pressure can be the weight of moving vehicles or the weight of people walking on it. The output of the piezoelectric material is not constant. Therefore, a bridge circuit is used to convert this variable voltage into a linear one. Again, an AC ripple filter is used to filter out any other fluctuation in the output. The DC output voltage is stored in a rechargeable battery. Because the output power of a single piezoelectric film was extremely low, the combination of some piezoelectric films was studied. Two possible connections were tested: parallel and serial connections. The parallel connection did not show a significant increase in the output voltage. With the series connection, the additional piezoelectric film increases the output voltage but not in linear proportion. Thus, a combination of parallel and serial connection is used here to produce a voltage output of 40 V with high current density. Battery regulations are provided to connect the DC load. An inverter is connected to the battery to provide power to connect the AC load. The voltage produced through the tile can be seen on an LCD screen. For this, the PIC16F873A microcontroller is used. The microcontroller refer a crystal oscillator for its operation. The microcontroller output is delivered to the LCD screen which then shows the voltage levels.

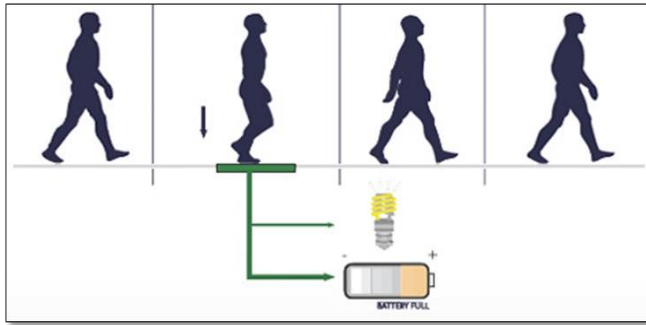

Fig.2.5: Schematic representation of the working model

The energy generated is given to the reducing transformer and the voltage is reduced and this output is given to street lighting and illuminated.

2.6: Advantages:

- i. Does not require manual labor during generation.
- ii. simplicity.
- iii. There is no problem in transporting fuel.
- iv. cheap.
- v. easy to maintain.
- vi. Easy to control.
- vii. Reduces the cost of labor.
- viii. Low energy consumption.
- ix. Energy available all year.
- x. Economic development.

2.7: Disadvantages:

- i. Piezo can produce voltage only when there is a constant pressure difference.
- ii. The piezo can not give HIGH digital, if some vehicle stops longer.
- iii. Turn on the light even with the movement of the animals.

3. CONCLUSION

The project has been successfully tested, which is the best economic and economic energy solution for ordinary people. This can be used for many applications in areas of the city where more power is desired. This system is a renewable energy resource and the energy generation that uses this technology is not only environmentally friendly, but also clean, profitable and safe. Sustainable development is possible through the adoption of this technology.

4. ACKNOWLEDGEMENT

We take this opportunity to express our gratitude and our debt to our guide, Ms. K. P. Mahure, researcher, Department of Electrical Engineering (E & P), who has been a constant source of guidance and inspiration in the preparation of this document.

REFERENCES

- [1] G. Jithendra Naidu, K. Pranay Kumar Reddy & S. Siva Prasad, "Piezo Based Electric Power Generation Using 3-Dimensional Mechanical Vibrations Produced in Vehicles," *International Journal of Electrical and Electronics Engineering (IJEEE)*, vol. 2, no. 1, 2012.
- [2] G. K. Ottman, H. Hofmann and G. A. Lesieutre, "Optimized piezoelectric energy harvesting circuit using step-down converter in discontinuous conduction mode", *IEEE Trans. Power Electron.* 2003, Vol. 18, no. 2, pp. 696–703.
- [3] Kapse Sagar Sudhakar, Abhale Amol Anil, Kudakechetan Ashok and Shirsath Shravan Bhaskar, "Automatic Street Light Control System," *International Journal of Emerging Technology and Advanced Engineering*, vol. 3, no. 5, May 2013.
- [4] L. Chao, C.-Y. Tsui, and W.-H. Ki, "A batteryless vibration-based energy harvesting system for ultra low power ubiquitous applications," in *Proc. IEEE Int. Symp. Circuits and Systems*, May 2007, pp. 1349– 1352.
- [5] Luigi Martirano, giuseppeparise and Massimo Mitolo, "Electrical Safety of Street light systems", *IEEE, VOL. 26, NO. 3, JULY 2011*.
- [6] Md. Mostaqimillaharnab, Shah Md. Rahmot, Md. Ashrafulalamullah, Raton Kumar Nondy, A S M forhadulalam, Anik Paul Mishu "Generation of Electrical Energy Using Piezoelectric Material from Train Wheels: Bangladesh Perspective", *IEEE* 2014.
- [7] Mrinmoy Dey, Tawhida Akand, Sadeka Sultana, "Power Generation for Auto Street Light Using PZT", 978-1-4673-9695-0/15/\$31.00 ©2015 IEEE.
- [8] Tanvi Dikshith, Dhaval Shrivastava, Abhijeet Gorey, Ashish Gupta, Paragparandkar, Sumanthkatiyal, "Energy Harvesting via Piezo Electricity," *BVICAM's International journal of Information Technology (BIJIT)*, vol. 2, no. 2, July-December 2010.