

SERIES AND SHUNT COMPENSATION IN UPFC USING CASCADED MULTILEVEL INVERTER- A TRANSFORMERLESS APPROACH

R. Nagananthini

Assistant Professor, Department of Electrical and Electronics Engineering, Bannari Amman Institute of Technology, Sathyamangalam, India-638401

ABSTRACT:- In this paper, reactive power compensation is done by using two level Cascaded Multilevel Inverter arrangement with a transformer-less connection. H-Bridge based FACTS controller is used to compensate the shunt voltage and series current during fault condition. Transformer-less approach is to eliminate the certain power related issues in using transformer. Control mechanism for shunt voltage and series current compensation is done separately with PI controller. Capacitor sources for the multilevel inverter are control for the independent control of real and reactive power. For different operating conditions the DC link voltages of the capacitor sourced inverter is maintain constant. MATLAB Simulink results were presented for various load conditions and the THD was analyzed and compared for the system with and without transformer. Throughout this operation the DC link voltages were maintained constant to ensure a smoother operation

topologies. Analyzing all the three types of multilevel inverter the cascaded h-bridge type of inverter is dominance in certain factors like clamped diode vacancy and downsized capacitors. Large number of capacitors is main inconvenience in other types of multilevel inverter. Since controlling the DC link voltage is the predominant task, which become a unattainable task when the inverter has large number of capacitors[8]. From this cascaded h-bridge inverter is the best explication for static var compensation techniques. Using h-bridge inverter is also helpful in another way, since the power supply to the inverters will be the capacitors therefore separate power source is eliminated which in turn will stamp out the use of transformer[9]. Thus H-bridge inverter is used for the transformer-less operation and eliminates the disadvantages caused due to the pole-mounted transformer.

Keywords:Transformer-less operation, series and shunt compensation, Cascaded Multilevel Inverter, Unified Power Flow Controller, SPWM Technique, DC link voltage.

1. INRODUCTION

In present day electrical technology the usage of FACTS devise in transmission and distribution side is uplifted. The vital and proficient role of the Flexible AC transmission system is the reactive power compensation. FACTS devices such as STATCOM, SSSC, UPQC, UPFC, SVC and TCSC have been in use for voltage and current compensation. Apart from Q-compensation improving the power quality and voltage regulation are the notable advantages of facts devices[1]. Multilevel inverters are the desirable solution for reactive power compensation dealing in high power applications. This is because thistype of inverters deal with plethora of DC sources and it is done through capacitors [2] &[3].A small amount of active power is being drawn from the source inorder to compensate the converter losses. AnyhowCapacitor voltage unbalancingoccurs due to the incongruous nature of switching and conduction loss. Balancing is the paramount test in multilevel inverters. In [4] to [7] number of control schemesfor the voltage and current compensation has been discussed with different

Gyugi was the first one to propose the idea of unified powerflow controller in the year 1992. In last two decades because of the combined advantage of all the FACTS devices and separate control of active and reactive power, a wide research is going in this area on the domain of modeling, analysis and control [10]. Other notable advantages of this sophisticated type of FACTS devices arevoltage and phase angle regulation. Due to this ability of controlling in series as well as in shunt it has many practical applications [11]. These applications requires isolation transformer to separate each of its converter from the transmission line as shown in fig.1. Apart from this, pole mounted transformers are used in high voltage high power converters in order to meet the best quality outcome based on the required volt-ampere rating.

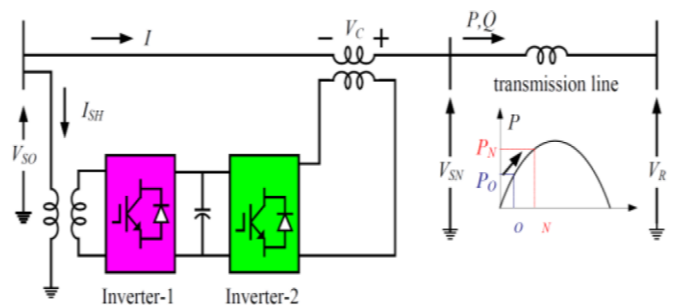

Fig-1:Series and Shunt compensation with transformer arrangement

The disadvantages that are associated in this pole mounted transformer are its high cost which accounts 40% of the total system cost, huge size which is 90% of the system weight and high loss which is 50% of the total power loss. The occurrence of failure is also high, is a serious term to be considered. Response of the system is the important outcome to calibrate the performance of the system, because of the larger time constant the system with pole mounted transformer has poor dynamic response which will drag down the control performance of the system. With poor dynamic and control performance this will not a perfect solution for a power transmission system by solar and wind energy, which needs fast track active power control. Summing up all this transformer-less operation will wipe out the loss, cost and size demerits of the system when it is under the transformer operation [12].The configuration is changed as shown in fig.2. to achieved the similarity in transformer operation and to achieve reliability.

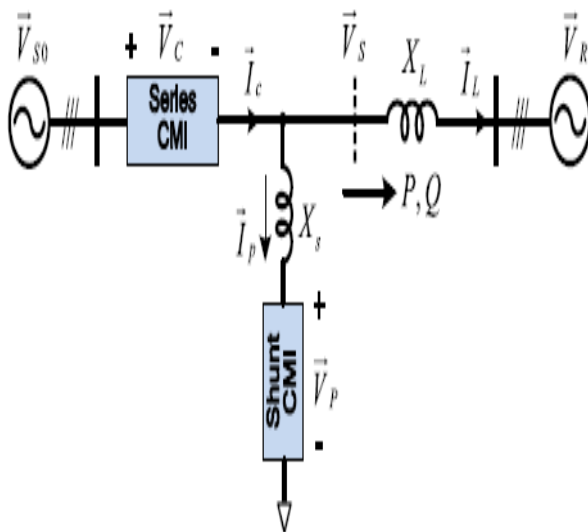

Fig-2:Shunt and Series connection configuration.

2. TRANSFORMER-LESS COMPENSATION TECHNIQUE:

Transformer is eliminated in this scheme, like it is used in conventional back-back DC coupling. Such that this arrangement will be low in cost, less in size, compact in size, fast in response and paramount in efficiency. The alteration is differed in the way of placing the series and shunt inverter. Series compensation comes first to the shunt compensation. This method of arrangement is to ensure that there is no swap of active power between the converters in the circuit. Without active power exchange the need of transformer is eliminated. This ensures a higher reliability and wider flexibility of the system.

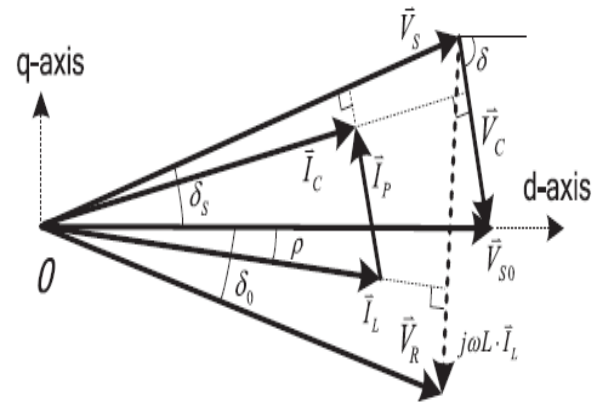

Fig-3:Operation of transformer-less compensation-phasor diagram

The basic operation of the transformer-less reactive power compensation system is differed from the conventional type because of its unique configuration. From fig.3 the idea behind the transformer-less operation is defined by the sending end voltage and current vectors and receiving end voltage and current vectors.

V_{S0} - First stage of Sending end voltage

V_R -Receiving end voltage

V_S -Second stage of sending end voltage

I_C - Current of series connected H-Bridge Cascaded Multilevel Inverter

I_P -Current of shunt connected H-bridge cascaded Multilevel Inverter

P_S -Active power flow into the series connected H-Bridge Cascaded Multilevel Inverter

P_P -Active power flow into the shunt connected H-Bridge Cascaded Multilevel Inverter

δ -the angle between the first stages of sending end voltage to the desired voltage level

Initial stage of sending and receiving end voltage will be V_S and V_R respectively. In order to attain the desired voltage V_C the series connected H-Bridge cascaded type Multilevel Inverter is controlled. Because of this voltage the sending end voltage is shifted to a new vector V_S is the second stage of sending end voltage. This shift in voltage will control the active and reactive power. The shunt connected H-bridge cascaded type Multilevel Inverter is controlled in such a way to inject the current I_P to the second stage of sending end voltage V_C to wipe out the active power.

From this we can recognize the controlled voltage source is the series connected cascaded type multilevel inverter and controlled current source is shunt connected cascaded type multilevel inverter. Since the currents I_C and I_P are parallel to their voltages V_C and V_S this ensures that there is

no swap of active power between the converters. To prove this the active power flow in the series connected H-Bridge CMI can be expressed as

$$P_s = V_c \cdot I_c \tag{1}$$

active power flow in the series connected H-Bridge CMI can be expressed as

$$\begin{aligned} P_p &= V_s \cdot I_p \\ &= (V_{s0} - V_c) \cdot (I_c - I_l) \\ &= (V_{s0} I_c) \cos(90^\circ - \delta) - (V_{s0} I_l) \cos \rho - V_c + \\ &V_c I_l \cos(\delta - \rho) \end{aligned} \tag{2}$$

Where V_{s0} is the First stage of Sending end voltage, I_c is the Current of series connected H-Bridge Cascaded Multilevel Inverter. Thus the active power flow in both shunt and series will be null. From this the power flow control and command over the line for the series converter is the desired value of voltage phasor V_c and the power flow control and command for the shunt connected inverter is the desired current phasor value is I_p , since $I_p = I_c - I_l$ is calculated from (1) and (2). From this the operation and it is affirm that the functionality of transformer-less system is similar to the pole-mounted transformer operation.

2.1 CURRENT COMPENSATION CONTROL METHODOLOGY:

The control methodology used in the control of current compensation is by generating the sine and cosine signals and applying them to the three phase supply voltage (V_a, V_b and V_c). Converter currents (I_a, I_b and I_c) in the synchronously rotated reference frame medium are transformed by the generated sine and cosine signals. Low pass filter is used to eliminate the frequency ripples caused due to switching the circuitry. References voltages are generated by the controller. Total DC link Voltage which is the summation of the DC link voltages across each converter. For the regulation of the total DC link voltage the converter lends a small amount of active current and give the desired reactive current. Apart from this control, one more control methodology is needed for the control of individual inverter DC link voltages. The active power transfer between the supply source and the inverter is depends on the value δ and it is comparatively less, when it is supplied to the grid from the inverter. The value of δ depends on the direct axis and quadrature axis voltage $\delta = \sqrt{e_{d2}^2 + e_{q2}^2}$ so the q-axis voltage reference component of the shunt connected inverter is analyzed from (3) to control the DC link voltage of the shunt connected inverter.

$$e_{q2}^* = (V_{dc2}^* - V_{dc2}) \left(k_{p4} + \frac{k_{i4}}{s} \right) \tag{3}$$

For the control of the series connected inverter the q-axis voltage reference component is analyzed by (4)

$$e_{q1}^* = e_q^* - e_{q2}^* \tag{4}$$

The DC link voltage of the series CMI is 0.36 times lesser than the shunt connected CMI. In order to express the DC link voltage of the inverter as a total DC link voltage $V_{dc} = V_{dc1} + V_{dc2}$ and from this the DC link voltage of inverter 1 & 2 can be calculated from (5) and (6) in terms of total DC link voltage

$$V_{dc1} = 0.73V_{dc} \tag{5}$$

$$V_{dc2} = 0.27V_{dc} \tag{6}$$

Where

V_{dc1} = DC link voltage of series/shunt connected H-bridge Cascaded Multilevel Inverter1

V_{dc2} = DC link voltage of series/shunt connected H-bridge Cascaded Multilevel Inverter1

Since two inverters are used in the H-Bridge CMI, so the direct and quadrature axis component are split into two on its total DC link voltage values as in equation (6) and (7). So the direct axis voltage component is split into

$$e_{d1}^* = 0.73e_d^* \tag{7}$$

$$e_{d2}^* = 0.27e_d^* \tag{8}$$

Equation (7) and (8) refers the positive reference voltage components whereas the negative voltage sequence components e_{dn}^* and e_{qn}^* are controlled using the below formulas, but the rotating reference frame will be negatively synchronous

$$e_{dn}^* = -x_3 - (\omega L) i_{qn} + v_{dn} \tag{9}$$

$$e_{qn}^* = -x_4 - (\omega L) i_{dn} + v_{qn} \tag{10}$$

In order to block the negative sequence current to flow through the inverter the negative sequence current reference values are assigned to zero.

2.2 VOLTAGE COMPENSATION CONTROL METHODOLOGY:

The control methodology used for compensation in series inverter is as follows. The source and load voltages are compared to obtain the reference voltage signals (11), (12) & (13) which is phase shifted by 120 degree. With the help of relay sub-system the switching signals are produced as shown in fig.4. These signals are applied to the upper arm of the series and shunt connected H-bridge cascaded multilevel inverter circuitry.

The NOT gate output of the signals which are synchronously rotated reference frame signals are applied

to the lower arm signals of the series/shunt connected inverter.

$$V_{ga} = V_L \sin(\omega t) \quad (11)$$

$$V_{gb} = V_L \sin(\omega t - 120^\circ) \quad (12)$$

$$V_{gc} = V_L \sin(\omega t + 120^\circ) \quad (13)$$

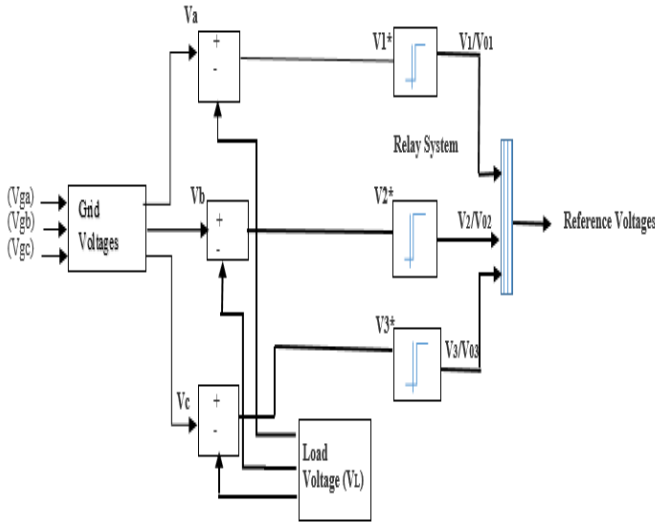

Fig-4. Switching Methodology in voltage compensation

Obtained level of voltages are given through the NOT process to provide the switching signals to the remaining switches.

This control methodology ensures the way of zero active power exchange that is the time of triggering will make the series and shunt connected inverter to produce the voltage phasor which is perpendicular to the reference voltage signals.

3. RESULTS AND DISCUSSION:

The Q-compensation is done in both series and shunt level using cascaded H-bridge inverter. MATLAB is used for observing the performance of the system.

Operating load conditions are changed accordingly to predict its performance by the output waveform. Fig. 5 is the complete MATLAB simulation circuit which comprises the series and shunt control block and its connection to the transmission line without transformer

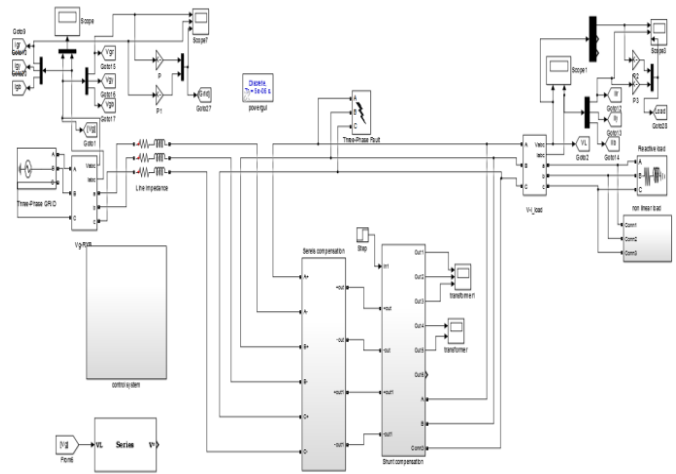

Fig-5: Complete circuitry of Shunt and Series connection without Transformer

For current regulation the control is taken by the H-bridge cascaded Multilevel Inverter circuit which is connected in parallel as shown in Fig. 5. Load analysis for reactive and harmonic basis is analyzed. Similarly for the voltage regulation the control is taken by the H-bridge cascaded Multilevel Inverter which is connected in series. And for reactive and harmonic load based conditions are taken account as a whole i.e., with shunt and series and the analysis is done accordingly. In both the control methodology the sinusoidal pulse width modulation technique was used for switching pulse generation.

Table-1: Specification of parameters in MATLAB

S.NO	PARAMETERS	SPECIFICATION
1.	Rated power of the system	2 MVA
2.	Carrier frequency	30KHz
3.	DC link voltage of series/shunt connected Inverter 1	241V
4.	DC link voltage of series/shunt connected Inverter 2	659V
5.	Equivalent DC capacitance of each H-bridge CMI	13000 μF
6.	line inductance X_s equivalent	0.22 p.u
7.	line inductance X_L equivalent	0.46.p.u

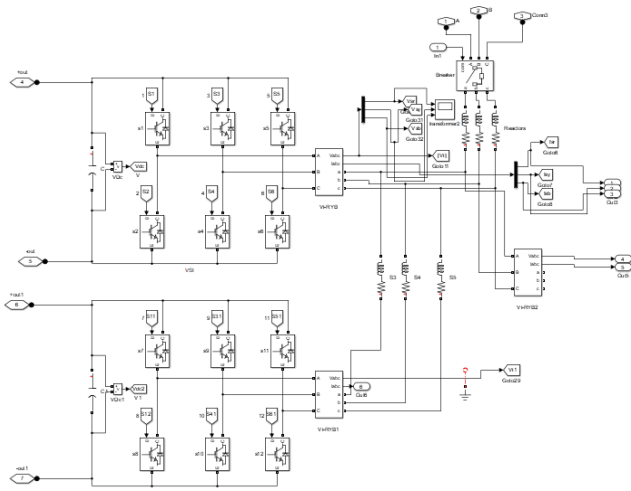

Fig-6: Current compensation Transformer-less connection Simulation diagram

Another problem that was faced is the presence of current ripple even after the compensation. This was overcome by the proper k_p and k_i values of the system. Fine tuning of this PI controller value helps to reduce it. In order to fully overcome this ripples when it comes for a prototype optimization techniques like meta-heuristic algorithms are suggested.

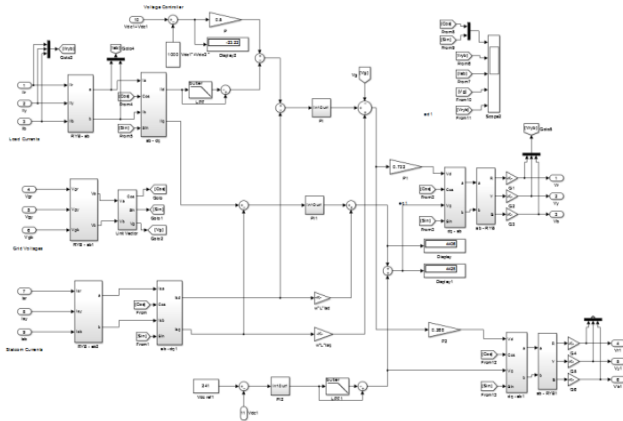

Fig-7: Control methodology for current compensation

For the sine and cosine signal generation the voltages from the grid is used as shown in fig.6. Transformation techniques like Inverse Park and park transformation technique is used to convert the voltage and current of three phase quantities to two phase quantities.

The direct and quadrature axis are the two phase components retrieved from the three phase. The direct axis lags 90 degree to the quadrature axis component as shown in fig.10. This is then used to produce the positive and negative sequence voltage and current components.

But the output of the control methodology again uses the transformation technique to produce the switching signals.

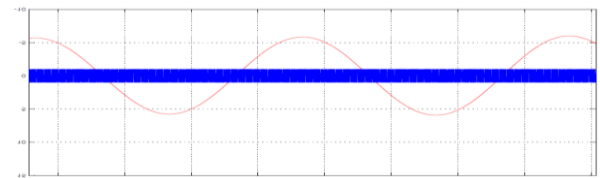

Fig-8: Carrier signal and Reference signal

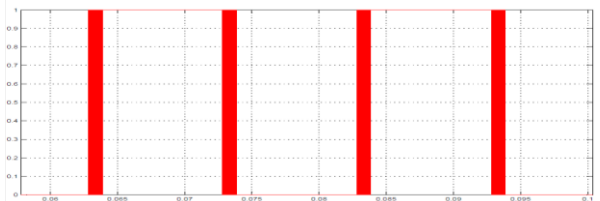

Fig-9: Switching signal output by SPWM technique

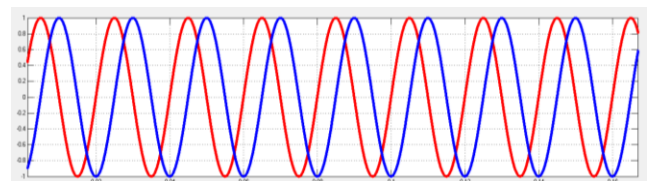

Fig-10: Sine and Cosine wave generation

For a system using transformer in supplying voltage to the inverter circuit, the low voltage side is connected to the Cascaded H-bridge inverter in series as well as in parallel connection and the high voltage side is associated with the transmission line system. Since for the voltage compensation circuit the 1:1 transformer arrangement is vital as mentioned before, thus the output of the cascaded H-bridge inverter output is networked to one side of the linear type transformer and then it is associated to the transmission line system as shown in fig.13.

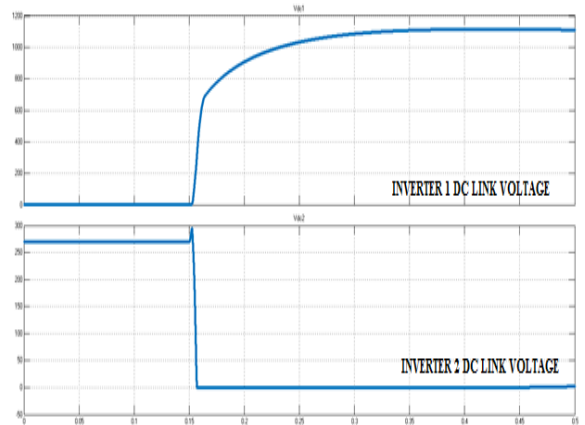

Fig-11: Output of Balanced DC link voltage

In order to compensate the losses that are associated with the transmission line parameters the RL series branch is connected in every output terminal before it is in contact with the network.

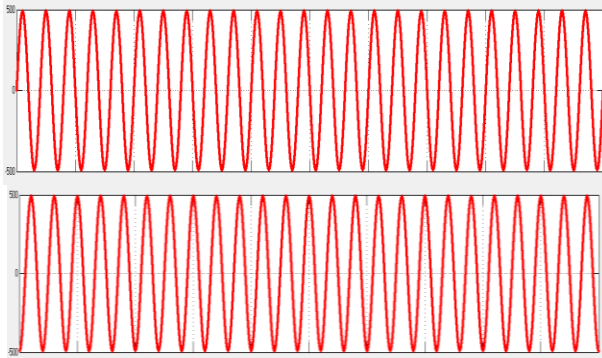

Fig-12: Transformed two phase quantity (direct and quadrature) output

The challenge that is mentioned before is the DC link voltage maintenance, here the Cascaded H-Bridge Multilevel Inverter 1 in both shunt and series level is maintained near 241V and the Cascaded H-Bridge Multilevel Inverter 1 in both shunt and series level is maintained near 649V and total of around 1000V is maintained as shown in fig.12. Thus the total DC link voltage will be the summation of individual DC link voltages across the circuitry to ensure the proper and smooth operation of the system as shown in fig.11.

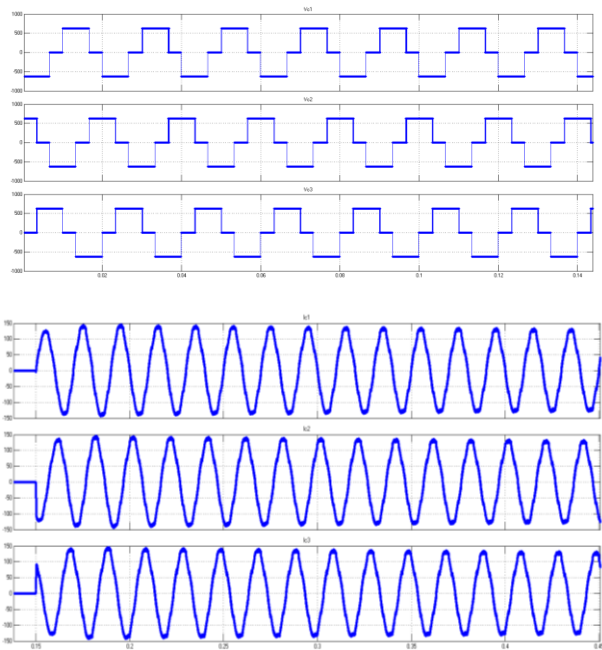

Fig-13:H-bridge inverter output a)voltage b)current

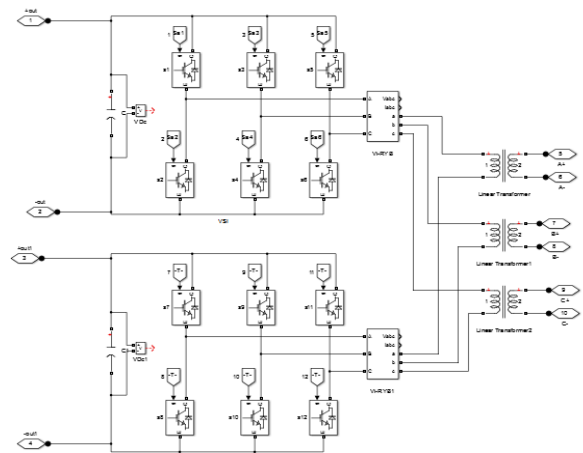

Fig-14: Voltage compensation with linear transformer connection

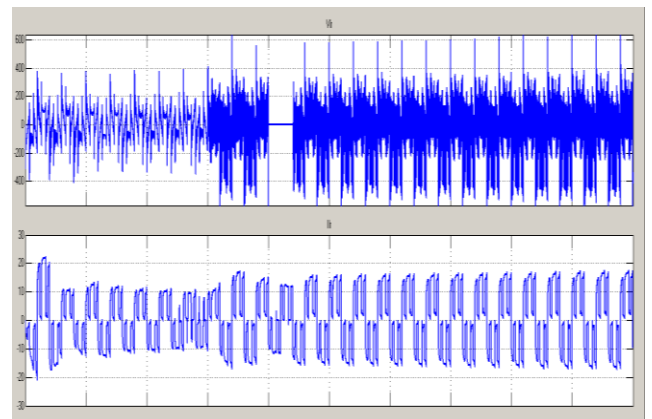

Fig-15: Transformer-less uncompensated output waveforms of grid voltage and current

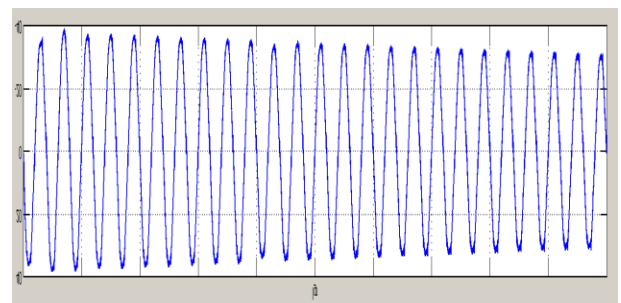

Fig-16: Transformer-less compensated output waveforms of grid voltage and current

4. CONCLUSION:

Current and voltage is compensated by the shunt and series connected H-bridge cascaded multilevel inverter circuitry, with-out using transformer. The connection done is the face to face connection which is different in arrangement of the series and shunt converters when

compared to the back to back connection. A three level inverter output voltage is achieved by the specific switching control strategy for series and shunt connected inverter. Reactive and harmonic load analysis are applied and compensation in voltage and current is achieved during this conditions. The paramount task of balancing the DC link voltage is achieved till the end of the operation. Eliminating the disadvantages of the transformer dependent module is the main idea behind, but it should be realized only in a prototype model by its less size, reduced weight and reduced cost. From the MATrix LABoratory Simulink point the advantages is compared with the circuit consist of transformer by its reduced total harmonic distortion.

REFERENCES:

- 1) 'Cascaded Two-Level Inverter-Based Multilevel STATCOM for High-Power Applications' N. N. V. Surendra Babu and B. G. Fernandes, IEEE transactions on power delivery, 2014.
- 2) 'Transformer-Less Unified Power-Flow Controller Using the Cascade Multilevel Inverter', Fang Zheng Peng, Yang Liu, Shuitao Yang, Shao Zhang, Deepak Gunasekaran, and Ujjwal Karki, IEEE transactions on power electronics, 2016.
- 3) 'Modulation and Control of Transformer-less UPFC' Shuitao Yang, Yang Liu, Xiaorui Wang, Deepak Gunasekaran, Ujjwal Karki, and Fang Z. Peng, IEEE transactions on power electronics, 2016
- 4) 'Transformer-less UPFC Using Multilevel Inverter' R. Vishwa Priya and Dr. S.K. Nandha Kumar, International Journal Of Engineering And Computer Science, 2017.
- 5) 'Control and performance of a transformer-less cascaded PWM STATCOM with star configuration', H. Akagi, S. Inoue, and T. Yoshii, IEEE Trans. Ind. Appl., 2007.
- 6) 'Hysteresis current control operation of flying capacitor multilevel inverter and its application in shunt compensation of distribution systems', A. Shukla, A. Ghosh, and A. Joshi, IEEE Trans. Power Delivery, 2007
- 7) 'Implementation of SSSC-Based Cascade H-Bridge Model using Compensation Technique', P. Shahanaz Salman, Nandyal, International Journal of Advanced Research in Electrical and Electronics and Instrumentation Engineering, 2015.
- 8) 'Static synchronous compensators (STATCOM): A review', B. Singh, R. Saha, A. Chandra, and K. Al-Haddad, IET Power Electronics, 2009.
- 9) 'Static synchronous compensators (STATCOM): A review', B. Singh, R. Saha, A. Chandra, and K. Al-Haddad, IET Power Electronics, 2009.
- 10) 'Cascaded Multilevel Inverter based Unified Power Flow Controller', International Journal of Advance Engineering and Research Development, R. Nagananthini, K. Ramadas, 2017.
- 11) 'Understanding FACTS', Hingorani and Gyugyi, IEEE, 2001.
- 12) 'A 6.6-kV transformer-less STATCOM based on a five-level diode-clamped PWM converter: System design and experimentation of a 200-V 10-kVA laboratory model', H. Akagi, H. Fujita, S. Yonetani, and Y. Kondo, IEEE transactions, 2008.