

Decoupled control technique of DFIG with dual PWM converters for Wind Power system using MATLAB/Simulink

Ananda DK¹, Jaya Kumar N²

¹PG Scholar, Dept. of Electrical Engineering, The Oxford College of Engineering, Karnataka, India.

²Associate Professor, Dept. of Electrical Engineering, The Oxford College of Engineering, Karnataka, India.

Abstract - Consequence of global environmental variations, swelling fuel prices and increasing energy demand in developing nations has directed the power industry to adopt green energy generation concept using renewable energy sources. Wind energy is one such favorable option, with most widely adopted configuration using Doubly Fed Induction Generator (DFIG) for variable speed wind turbines. Stator windings of the DFIG are directly connected to grid and rotor windings are fed by two back to back connected power converters. This paper details about decoupled control method for regulating the DFIG based variable speed wind turbine. To plug the maximum power from the wind Maximum Power Point Tracking (MPPT) using indirect method is developed and Pulse Width Modulation (PWM) technique is adopted for power electronic converter. Proposed system is designed, developed and simulated using MATLAB/SIMULINK

Key Words: Doubly Fed Induction Generator (DFIG), Variable speed wind turbine, Wind Energy Systems (WES), Maximum Power Point Tracking (MPPT), Vector control, Back-to-Back Converters, Pulse Width Modulation (PWM), MATLAB/SIMULINK.

1. INTRODUCTION

With increasing population, surge in the fossil fuel prices and increasing apprehension about the release of greenhouse gases, safety concerns regarding the usage of nuclear fuels resulted in energy generation through renewable energy sources. Day by day importance of energy generation from renewable energy sources is gaining more prominence. One such renewable source of energy is Wind energy. Oil crisis during 1970's encourage to generate large amount of power through wind turbines. Present-day wind power production cost and various incentive schemes and initiative from government agencies push the wind power generation to compete with other conventional sources [1]. One of the most widely used architecture in wind energy conversion system (WECS) is based on Doubly Fed Induction Generator (DFIG). There are various types of wind energy conversion systems such as Horizontal axis wind turbines and vertical axis wind turbines, but later one is more desirable. Stator windings of DFIG are directly connected with grid and rotor windings are connected to grid via back to back connected PWM power converters. Main advantage with this topology is power converter will handle 30% of the

generator power resulting in low rating of power semiconductor components.

Control of DFIG is of prime importance since the wind velocity may differ based on the geographical conditions and the generator needs to respond to quick changes in the wind speed with in short span of time [1] [2]. Many control schemes have been suggested, among them vector control strategy based on decoupling of rotor current components either with stator flux oriented or stator voltage oriented method will be adopted. The suggested approach decouples the doubly fed induction generator rotor current into two components to regulate active and reactive power independently by implementing two Proportional-Integral controllers. In order to extract maximum power from the existing wind speed maximum power point tracking [MPPT] with indirect speed control approach is adopted. In order to increase the obtainable output voltage Pulse width Modulation [PWM] with third harmonic injection method is implemented. Complete proposed system is illustrated in the Fig-1. The whole system is developed and simulated using MATLAB/SIMULINK.

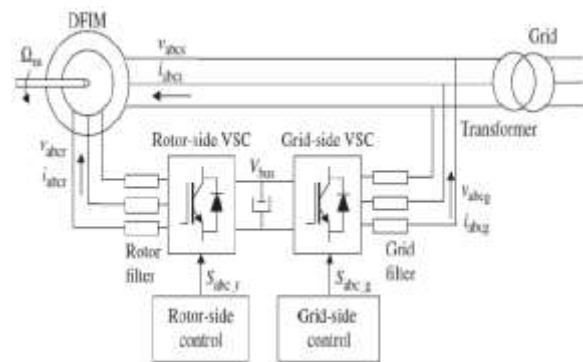

Fig-1: Proposed system block diagram

From Fig-1 it is evident that DFIG is coupled with variable speed wind turbine, the stator connects directly with grid and rotor windings are fed by two back to back voltage source converters namely rotor side converter [RSC] and grid side converter [GSC]. A DC bus connects the two voltage source converters. RSC regulates the active and reactive power whereas GSC maintains the DC bus voltage at constant magnitude.

2. WIND TURBINE MODELING

Kinetic energy of the wind results in rotary movement of wind turbine blades converting moving energy of the wind

into mechanical energy, which in turn gets converted into electrical energy using generator. When wind blows past the turbine blades bringing lift and apply rotational force. The turbine blades revolve a shaft which in turn connects with the gear box [2]. The gear box helps in increasing the rotational speed from low speed shaft.

Power confined in the wind having wind speed (V_w) passing through the surface area of turbine blades (A) can be given by

$$P_w = 0.5 \rho A V_w^3 \quad \dots(1)$$

Where ρ = Density of the air in kg/m^3

Certain portion of the power available in the wind can be plugged by wind turbine. The mechanical power captured by the wind turbine is found using

$$P_m = 0.5 \rho \pi R^2 V_w^3 C_p \quad \dots(2)$$

Where R = length of the turbine blades in mts, C_p is factor of coefficient.

The Tip speed ratio is defined as the ratio of blade tip speed to incoming wind speed [3]

$$\lambda = \frac{\Omega_t R}{V_w} \quad \dots(3)$$

Where Ω_t = Wind turbine speed in rad/sec

Aerodynamic model signifies the power extraction of the rotor, deriving mechanical torque as a function of air flow on the turbine blades. Mechanical power captured by turbine is expressed in terms of torque as below

$$T_t = 0.5 \rho \pi R^3 \frac{C_p(\lambda)}{\lambda} V_w^2 \quad \dots(4)$$

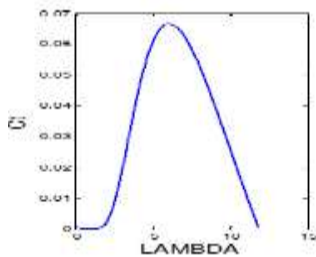

Fig-2: Curve showing relationship between C_t and lamda

3. DOUBLY FED INDUCTION GENERATOR

Stator windings of DFIG machine is directly connected with grid and rotor windings are connected to grid through back to back arranged voltage source converters RSC and GSC. Voltage source converter allows wide range of variable speed operation of the wound rotor induction machine. The capacitor which interlinks RSC and GSC acts as a constant DC voltage source and like an energy storage element. Converter control system generates switching pulses to regulate rotor side converter and grid side converter. RSC regulates the active power generated from the wind turbine and GSC controls the Dc bus voltage and reactive power. With the help of rotor side converter voltage fed into the rotor windings of the DFIG can be varied in order to control the rotor current.

At synchronous speed the magnetic field of the rotor rotates at the same speed as that of the stator magnetic field then the machine behaves like a asynchronous machine with DC current in the rotor windings meaning that no active power is generated from rotor windings and all the active power from the machine will flow from stator windings of the machine into the grid. When the wind speed increases, rotor speed increases beyond the synchronous speed causing negative slip resulting in super synchronous operation with this condition both stator windings and rotor windings of doubly fed induction generator supplying power to the grid. When the wind speed decreases the rotor speed of the DFIG reduces causing positive slip and machine operates at sub synchronous mode with this rotor windings absorbs power from the grid consuming power for excitation of the rotor windings[4].

3.1 DFIG Model

With the application of transformation matrix such as Clarke and its inverse transformation three phase variable quantities can be converted into two stationary quantities referred to as $\alpha\beta$ quantities. With the help of rms value of the $\alpha\beta$ components it is possible to find out the voltage angle which is helpful in transforming the variables from $\alpha\beta$ to dq frame by adopting parks transformation or vice versa

$$\phi = \tan^{-1} \left[\frac{\beta}{\alpha} \right] \quad \dots(5)$$

Where ϕ = angle component

Equation 5 can be implemented in Matlab as

$$\phi = \text{atan2} [\alpha/\beta]$$

In order to develop dynamic model of the DFIG space vector theory is adapted to the basic equations of the machine.

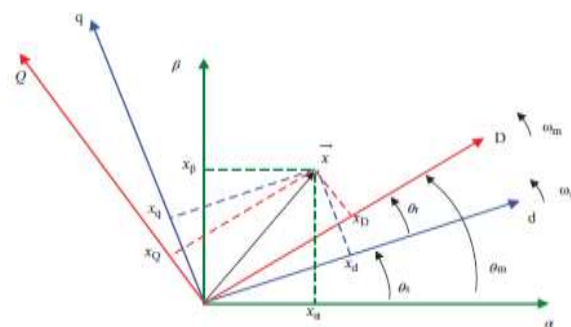

Fig-3: Various reference frames showing space vectors of DFIM

Fig. 3 shows three different rotating reference frames used to develop space vector based models of DFIG. Stator reference frame $\alpha\beta$ is a stationary frame. Rotor reference frame DQ rotates at ω_m and synchronous reference frame dq rotates at ω_s . By using Clark, park and its inverse transformations a space vector can be represented in any of these frames [5].

3.2 $\alpha\beta$ Model

Voltage equations of stator and rotor can be expressed in terms of space vector representation

$$V_s = R_s i_s + \frac{d\phi_s}{dt} \quad \dots \dots (6)$$

$$V_r = R_r i_r + \frac{d\phi_r}{dt} \quad \dots \dots (7)$$

Expressing the stator voltage expression in stationary reference frame as below

$$V_{\alpha s} = R_s i_{\alpha s} + \frac{d\phi_{\alpha s}}{dt} \quad \dots \dots (8)$$

$$V_{\beta s} = R_s i_{\beta s} + \frac{d\phi_{\beta s}}{dt} \quad \dots \dots (9)$$

$V_{\alpha s}, V_{\beta s}, i_{\alpha s}, i_{\beta s}$, and $\phi_{\alpha s}, \phi_{\beta s}$

are the stator voltages, currents and flux linkages in stationary reference frame. R_s is stator windings resistance in ohms..

Electromagnetic torque developed by the doubly fed induction generator is given by

$$T_{em} = \frac{3}{2} p [\phi_{\beta r} i_{\alpha r} - \phi_{\alpha r} i_{\beta r}] \quad \dots \dots (10)$$

Where p = number of pole pairs

3.3 dq Model

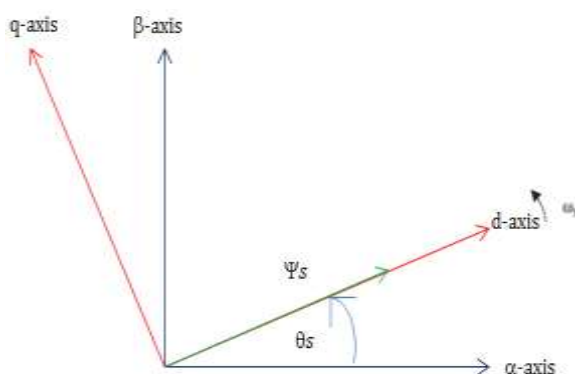

Fig-4: DFIG Stator flux orientation in dq frame

Space vector model of the DFIG can also be represented in synchronously rotating frame by multiplying the voltage expression by $e^{-j\theta_s}$ and $e^{-j\theta_r}$ for stator and rotor voltage respectively. Hence dq voltage equations [5] can be expressed as shown in the equations 13 and 14.

$$V_s = R_s i_s + \frac{d\phi_s}{dt} + j\omega_s \phi_s \quad \dots \dots (11)$$

$$V_r = R_r i_r + \frac{d\phi_r}{dt} + j\omega_r \phi_r \quad \dots \dots (12)$$

Expressing above voltage equations in dq coordinates

$$V_{ds} = R_s i_{ds} + \frac{d\phi_{ds}}{dt} - \omega_s \phi_{qs} \quad \dots \dots (13)$$

$$V_{qs} = R_s i_{qs} + \frac{d\phi_{qs}}{dt} + \omega_s \phi_{ds} \quad \dots \dots (14)$$

$V_{ds}, V_{qs}, i_{ds}, i_{qs}$, and ϕ_{ds}, ϕ_{qs} , are the stator voltages, currents and flux linkages in synchronous reference frame. R_s is the stator winding resistance in ohms.

Similarly electromagnetic torque developed by the DFIG in dq coordinates is given by

$$T_{em} = \frac{3}{2} p L_m [i_{dr} i_{qs} - i_{qr} i_{ds}] \quad \dots \dots (15)$$

4. CONTROL METHOD

DFIG based wind turbine systems consists of two controllers referred as Rotor side converter and Grid side converter. RSC regulates the active power and reactive power where as GSC controls the DC-link voltage and exchange of power between the grid [6].

4.1 Rotor Side Converter

Stator flux method of vector control technique is employed such that direct axis aligned with stator flux component as illustrated in the fig4. We know that stator flux is proportional to grid voltage V_g .

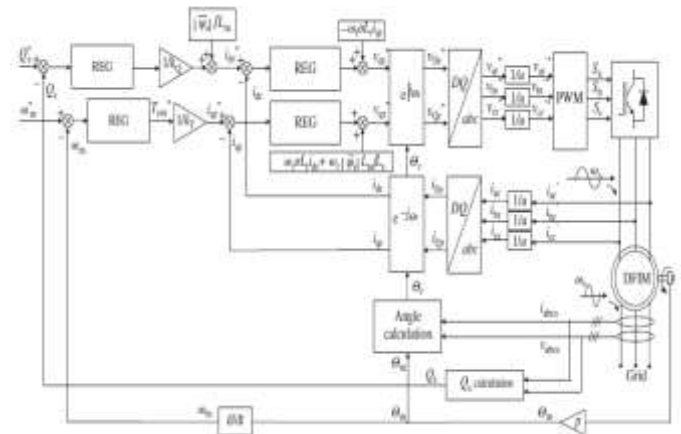

Fig-5: Control approach of RSC

By neglecting the minute drop in the stator resistance gives

$$V_{ds}=0; V_{qs}=V_g \text{ where } \Psi_s=\Psi_{ds} \text{ and } \Psi_{qs}=0$$

Fig 5 represents the control block diagram of the rotor side converter. To achieve the control measured three phase voltage quantities are converted using Clarke's transformation to obtain alpha-beta components to obtain stator flux, further the required angle is calculated for parks transformation matrix to convert stator currents into dq coordinates. This transformation helps us in finding out the d and q- axis rotor current. Actual speed of the doubly fed induction generator is measured and compared with the reference speed, difference in the speed results in the error signal which is being fed into the controller as the input signal, controller output is torque reference which provides the q-axis rotor current component. This reference component is compared with the actual q-axis rotor current and difference signal is provided as input signal for the current controller to regulate the q-axis rotor voltage component. Similarly one more PI current controller will be employed to control the reactive power [7]. By using inverse transformation equations two voltage components are transferred back to three phase quantities which results in generation of reference voltage signals for PWM controller which in turn regulates the switching pulses.

4.2 Grid Side Converter

Objective of the grid side converter is to regulate the DC link voltage and maintain unity power factor [8]. Mathematical of the inverter in alpha-beta model can be represented as below

$$V_{\alpha f} = R_f i_{\alpha g} + L_f \frac{di_{\alpha g}}{dt} + V_{\alpha g} \quad \dots(16)$$

$$V_{\beta f} = R_f i_{\beta g} + L_f \frac{di_{\beta g}}{dt} + V_{\beta g} \quad \dots(17)$$

By multiplying the above equations by $e^{-j\theta}$ we can express the equations in dq model [8] [9].

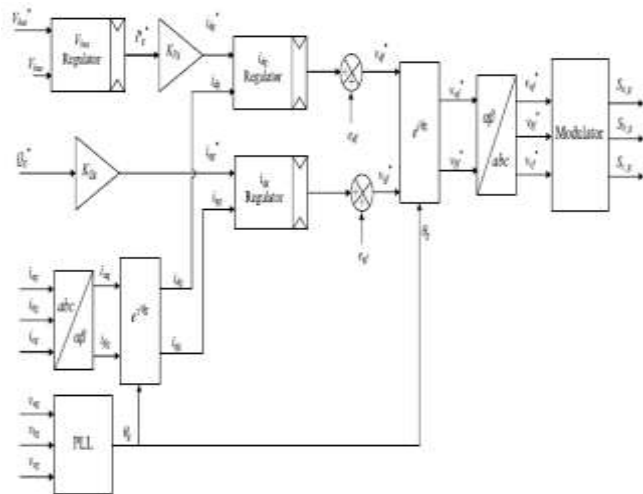

Fig-6: Block diagram of Grid side converter

Unity power factor is obtained by setting the reactive power reference to zero. The DC reference voltage is compared with the measured DC voltage across the DC bus capacitor. The DC voltage regulator controls the Dc bus and sets the active power which is essential to charge the capacitor to the desired value [10]. The evolution of DC voltage V_{dc} is given by the following equation

$$i_c = C \frac{dv_{dc}}{dt} \quad \dots(18)$$

Where i_c = capacitor current

5. SYSTEM MODELLING

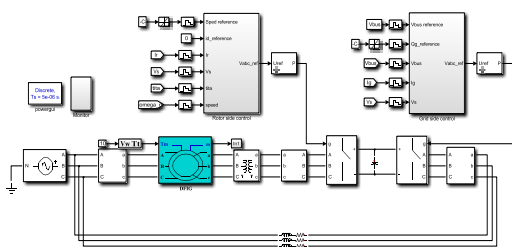

Fig-7: Projected system representation using Simulink

Fig-7 shows the implementation of the proposed system using Simulink. The entire system is made up of many complex subsystems such as wind turbine aerodynamics, maximum power tracking, Rotor side converter, Grid side converter, these subsystems are implemented

autonomously and integrated to achieve the control of the Doubly Fed Induction Generator. Some of the subsystems are illustrated in the coming sections.

5.1 Wind Turbine

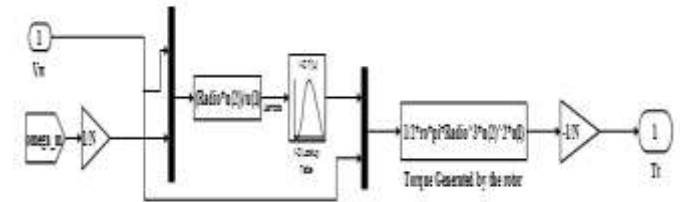

Fig-8: Representation of Wind turbine using Simulink

By considering the wind speed and turbine shaft speed it is possible to find out the lambda value. By implementing look up table torque coefficient is calculated. Subsequently the ratio of the gear box must be considered to find out the actual developed torque since the implemented system is stated to lesser rotational shaft [11].

5.2 Maximum Power Tracking

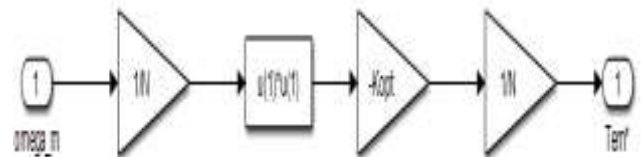

Fig-9: Maximum power point tracking block

Objective of speed control strategy is to make best use of the power extraction referring to the curve illustrating power coefficient and lambda [12]. In order to realize maximum power point tracking the control strategy adopted is based on the technique mentioned as indirect speed regulator method.

5.3 Rotor side control block

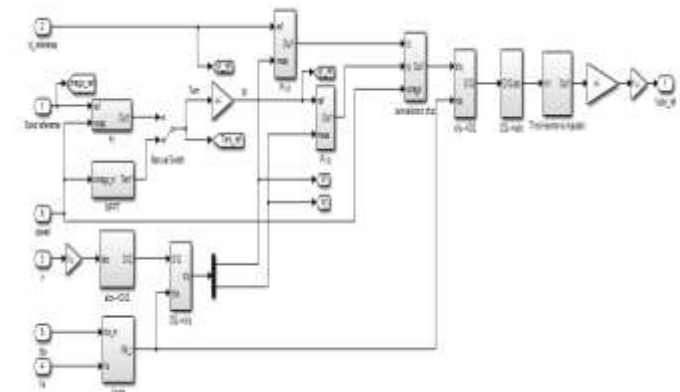

Fig-10: Rotor side control block implementation using simulink

Control strategy implemented using Simulink for rotor side converter is shown in the fig-10. Stator current and voltage are transferred to suitable coordinate system to regulate the system and corresponding Simulink blocks are shown.

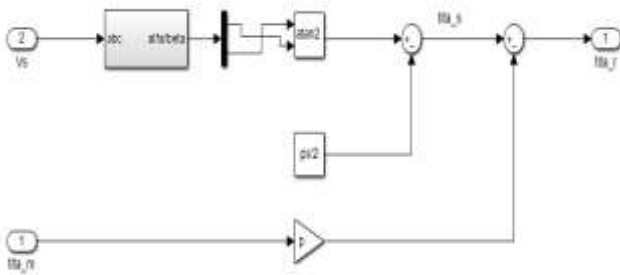

Fig-11: Implementation of angle block using Simulink

To transform the variables to various coordinate system such as from three phase quantities into stationary alpha-beta reference frame to rotating reference frame transformation matrix are required. One such transformation required angle θ [13] [14] for transforming the $\alpha\beta$ components to dq coordinates. Fig-11 assists in finding the angle θ for such transformations.

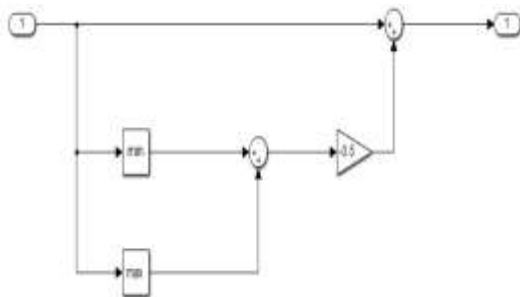

Fig-12: Injection of third harmonic technique using Simulink

In order to boost the peak value of the primary component the block shown in the fig-12 is implemented such that it injects third harmonics into the voltage reference signal [15] to achieve maximum achievable output voltage.

5.4 Grid side control block

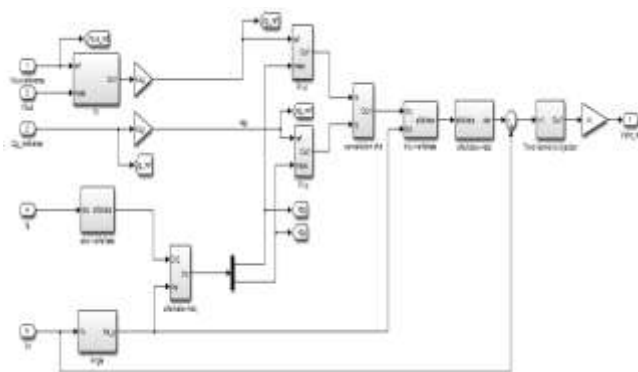

Fig-13: Grid side control block implementation using Simulink

6. SIMULATION RESULTS

6.1 Considering Wind speed of 8 meters per second

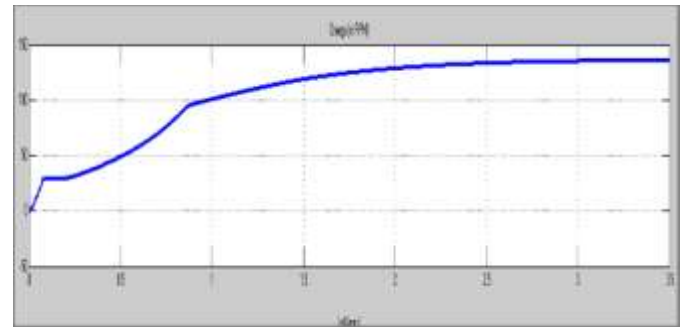

Fig-14: Simulation curve illustrating revolving speed of DFIG

Above graph represents the revolving speed of the DFIG versus time. It is clearly visible that gradually speed is increasing till 1 sec after the start of simulation and finally to arrive at steady state 3 secs is required and will attain a speed 137.5 rad./sec.

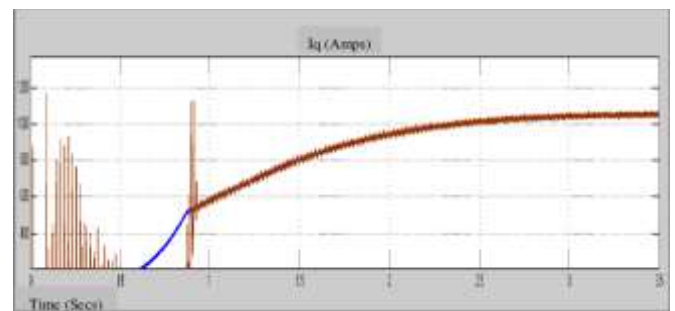

Fig-15: Response of reference and measured q-axis rotor current

As discussed q-axis component regulates the torque, fig-15 shows the response of real and measured q-axis component of rotor current.

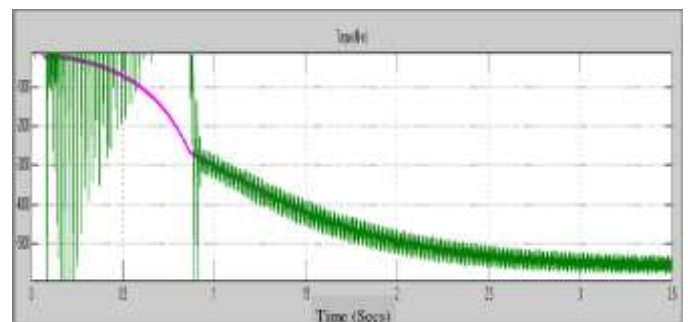

Fig-16: Response of reference and measured electromagnetic torque

From the figure it is observed that initially there will be lot of disturbances due to startup of the machine which is not recommended method of startup. It can be observed that around 0.9 secs after the startup the measured torque follows the reference value.

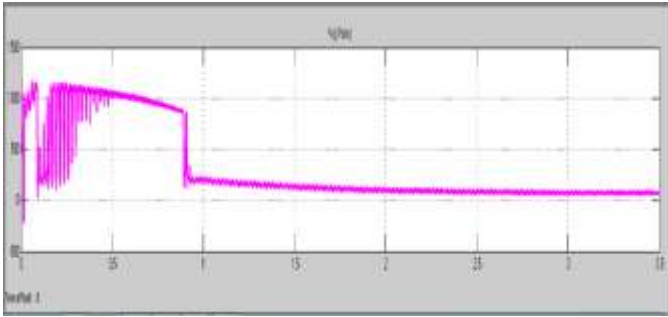

Fig-17: Response of q-axis voltage

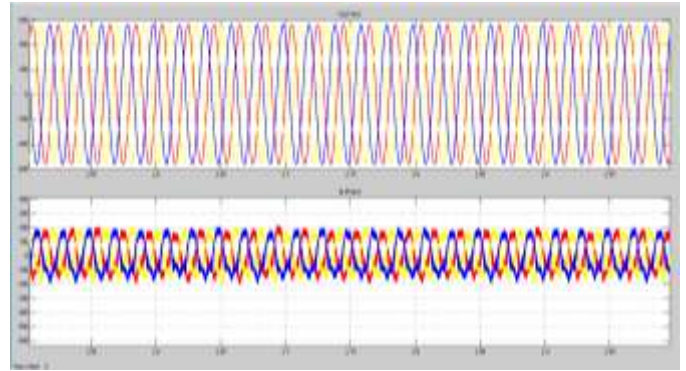

Fig-20: Measured Grid voltage and Grid current respectively

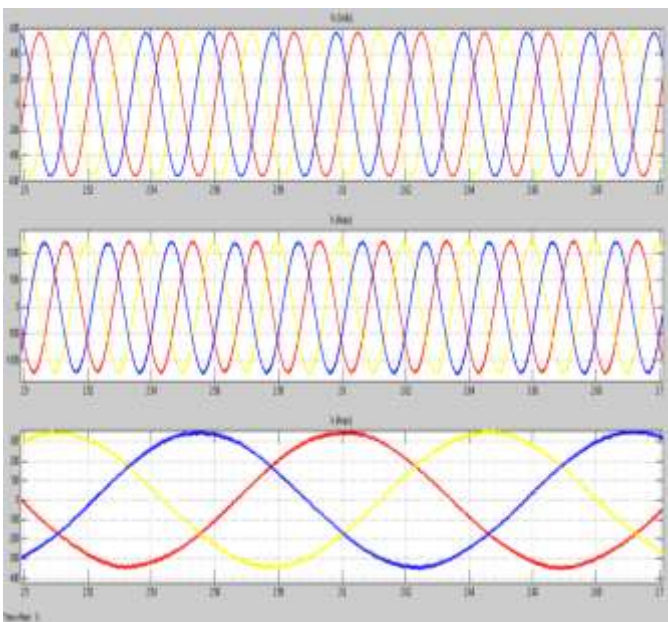

Fig-18: Measured values of Stator voltage, current and rotor current respectively

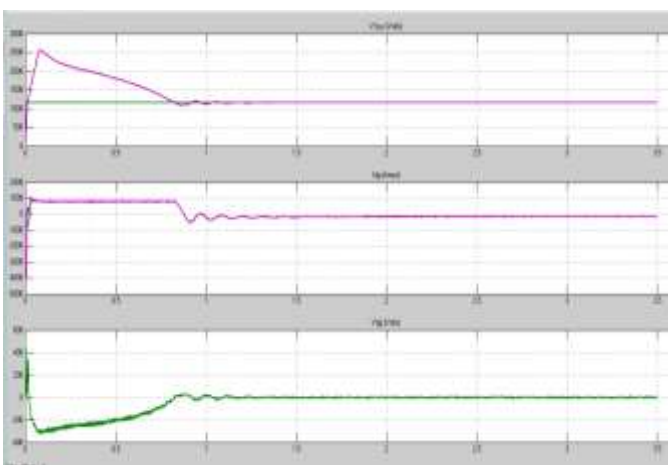

Fig-19: Response of DC bus voltage

6.2 Increase in Wind speed to 10 meters per second

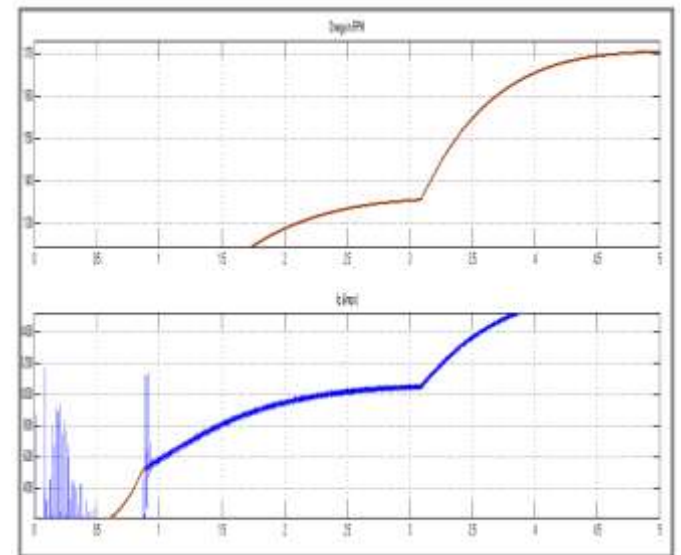

Fig-21: Response of the revolving speed and q-axis rotor current for change in wind speed

From the fig-21 it can be observed that till 3 secs the system was operating with a wind speed having a velocity of 8 meters/sec, however during the time interval at 3.05 to 3.10 sec the wind speed was made to increase from 8 meters/ sec to 10 meters/sec. causing increased rotational speed of the machine and quadrature axis current to adjust the torque as shown in the fig-22

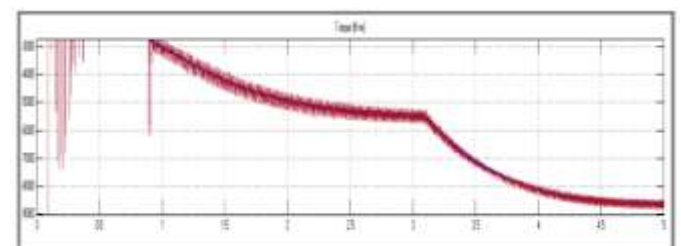

Fig-22: Response of DFIG electromagnetic torque

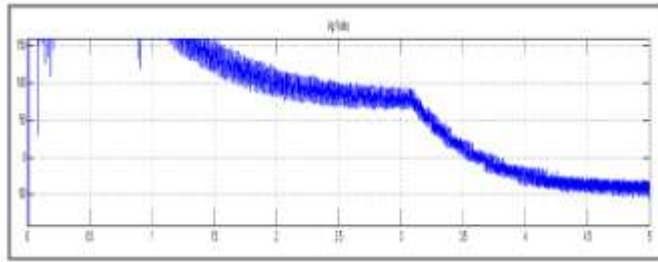

Fig-23: Quadrature axis voltage Response for change in wind speed

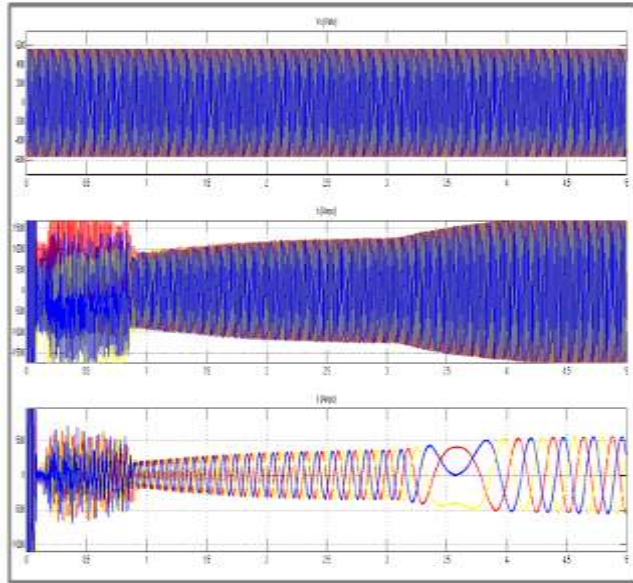

Fig-24: Response of stator voltage, current and rotor currents respectively

From the fig 24 it is evident that for a variation in wind speed it is clearly noticeable that there is a change in the magnitudes of the stator current and rotor currents. It is also observable that rotor current experiencing disturbance at the time interval 3.5 secs for change in wind speed.

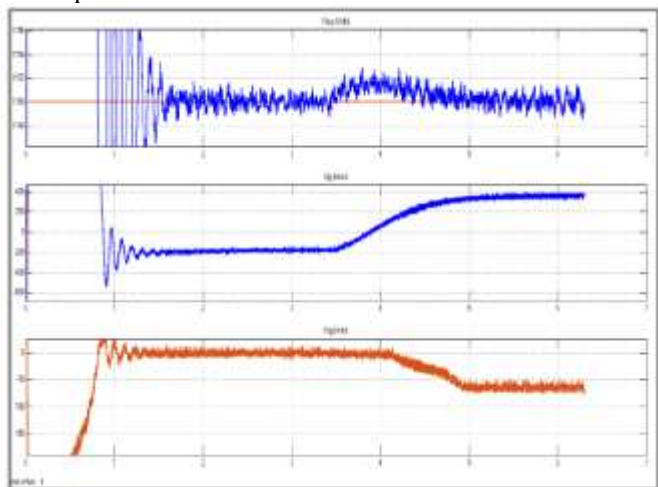

Fig-25: Response of DC bus voltage for change in wind speed

6.3 Generator Data

Table -1: Generator data

Description	Values	Description	Values
Nominal Power	2000KW	Frequency	50HZ
Nominal speed	1500RPM	Number of pole pairs	2
Nominal Voltage stator	0.69KV	Stator resistance	2.6mΩ
Nominal voltage rotor	2070V	Rotor Resistance	2.6mΩ

CONCLUSION

This paper presents the control approach implemented in regulating the Doubly Fed Induction Generator for wind energy systems. Detailed modeling of wind turbine aerodynamics, grid side converter and rotor side converter are presented. Maximum power point tracking based on indirect speed control approach is adopted to plug the maximum energy from the wind. As illustrated in the previous sections decouple control strategy aids in achieving the control of grid side and rotor side converter to regulate the machine speed, electromagnetic torque, active and reactive power and DC bus voltage. The system is designed, modelled and simulated using the MATLAB/Simulink software. Hence Doubly Fed Induction Generator is appropriate solution for such systems as it can easily adapts itself for different wind velocity.

REFERENCES

[1] Yu Zou, Malik E Elbuluk, Yilmaz Sozer, "simulation comparison and implementation of induction generator wind power systems," IEEE Trans. Ind. Appl. vol.49, No.3, May/June 2013.

[2] Milkias Berhanu Tuka, Roberto Ledihold, Mengesha Mamo, Modeling and control of a doubly fed induction generator using a back to back converters in grid tied wind power system. Presented at IEEE PES-IAS power Africa 2017.

[3] Sergio Busquets-Monge, Joan Rocabert, Pedro Rodriguez, Salvador Alepuz, Josep Bordonau, "Multilevel diode clamped converter for photovoltaic genertaors with independent voltage control of each solar array", IEEE trans.on Ind. Elecs, 2008, Vol.55, pp 2713-2723.

[4]G Abad, J. Lopez, M.A. Rodriguez L. Marroyo and G. Iwanski, " Vector control strategies for grid connected DFIM wind turbines", in doubly fed induction machine:

Modeling and control for wind energy generation, John Wiley & Sons, Inc, 2011. P.304.

[5] Haitham Abu-Rub, Mariusz Malinowski and Kamal Al-Haddad, *Power Electronics for Renewable Energy Systems, Transportation and Industrial Applications*, 2014, IEEE Press and John Wiley and Sons Ltd.

[6] Y Bekakra, D.B. Attous, "Active and reactive power control of a DFIG with MPPT for variable speed wind energy conversion using sliding mode control", *World Academy of Science, Engineering and Technology* 60, 2011.

[7] Badrul H. Chowdhury and Srinivas Chellapilla, "Double-fed induction generator control for variable speed wind power generation", *Electric Power Systems Research*, volume 76, Issues 9-10, June 2006, pp. 786-800

[8] Amirnaser Yazdani, Reza Iravani, "Voltage Sourced Converters in Power Systems, Modeling, Control and Applications", 2010, John Wiley and Sons Inc.

[9] Singh B, Naidu N.K.S, "Direct power control of single VSC based DFIG without rotor position sensors", *IEEE Trans. Ind. Appl.* 2014, 50, 4152-4163.

[10] CM Rahul Charles, V Vinod, Anju Jacob - Field oriented control of doubly fed induction generator in wind power system. Presented at IEEE International Conference on Computational Intelligence and Computing Research 2015.

[11] Vijay Chand Ganti, Bhim Singh, Shiv Kumar Aggarwal, "DFIG based wind power conversion with Grid power Levelling for reduced gusts", *IEEE Trans. Sustainable Energy*, vol.3, No.1 Jan 2012.

[12] G Venu Madhav and Y P Obulesu, "Direct torque control strategy for doubly fed induction machine under low voltage dips", *IJPEDS*, vol.2, No.4, December 2012, pp. 409-416 2012.

[13] E. Muljadi and CP Butterfield, "Pitch-controlled variable speed wind turbine generation", *IEEE Transactions on Industry Applications*, vol.37, No.1, January/February 2001

[14] R Pena and J.C. Clare, "Doubly fed induction generator using back to back PWM converters and its application to variable speed wind energy generation", *Proc. IEEE, Electric Power Applications*, vol.143, No.3, pp.231-241, May 1996.

[15] Remus Teodorescu, Macro Liserre and Pedro Rodriguez, *Grid Converters for Photovoltaic and Wind Power Systems*, First ed. 2011, John Wiley and Sons, Ltd.