

## Linear Buckling Analysis of Atlas Torpedo

Pothuraju.V.V.Satyanarayana<sup>1</sup>, K. Jyothi Rani<sup>2</sup>, P. Satya Lakshmi<sup>3</sup>, M. Murali Krishna<sup>4</sup>

<sup>1</sup>Assistant Professor, Department of Mechanical Engineering, Avanthi Institute of Engineering and Technology, Makavarapalem, Visakhapatnam, INDIA.

<sup>2</sup>Post Graduate student, Department of Mechanical Engineering, Visakha Technical Campus, Narava, Visakhapatnam, INDIA.

<sup>3</sup>Assistant Professor, Department of Mechanical Engineering, Visakha Technical Campus, Narava, Visakhapatnam, INDIA.

<sup>4</sup>Professor, Department of Mechanical Engineering, Visakha Technical Campus, Narava, Visakhapatnam, INDIA.

\*\*\*

**Abstract** - In this paper Atlas torpedo is modeled using finite elements and its static characteristics are analyzed subject to variations in the design parameters structural problem. While launching of these torpedoes, the torpedo experiences the water entry shock. The shell was analyzed for the shock load. The stresses developed due to the above shock load were found to be within the acceptable limit. Buckling is a sudden failure of a structural member subjected to high compressive stress and it is a structural instability leading to a failure mode. Buckling strength of structures depends on many parameters like supports, linear material, composite or nonlinear material etc. This project intends to study buckling behavior of Torpedo which is influenced by Static structural.

The Geometry of the models is carried out in the CATIA V5 R20 Software and is designed in Mechanical Design. The analysis part is done by using the ANSYS R14.5 & R15.0 Software.

**Key Words:** Atlas, Buckling, CATIA, ANSYS.

### 1. INTRODUCTION

The torpedo is one of the oldest weapons in the naval inventory, having been invented over 130 years ago, but at the same time it remains one of the deadliest anti-ship and anti-submarine weapon, it is far more lethal to submarines and surface ship than any other conventional weapon. torpedo warhead explodes under water, and that increases its destructive effect. When projectile explodes, the surrounding air absorbs a part of its force. Homing torpedoes are a relatively recent development they have been perfected since the end of World War II. With homing torpedoes, a destroyer can attack a submerged submarine, even when its exact position and depth are unknown.

When a structure is subjected to compressive stress, buckling may occur. Buckling is characterized by a sudden

sideways deflection of a structural member. This may occur even though the stresses that develop in the structure are well below those needed to cause failure of the material of which the structure is composed. As an applied load is increased on a member, such as a column, it will ultimately become large enough to cause the member to become unstable and it is said to have buckled. Further loading will cause significant and somewhat unpredictable deformations, possibly leading to complete loss of the member's load-carrying capacity. If the deformations that occur after buckling do not cause the complete collapse of that member, the member will continue to support the load that caused it to buckle. If the buckled member is part of a larger assemblage of components such as a building, any load applied to the buckled part of the structure beyond that which caused the member to buckle will be redistributed within the structure.

### 2. WORKING PRINCIPLE OF THE TORPEDO

The torpedo is equipped with mechanical devices which make it self-propelling after it is launched. The reduced pressure air also fires the igniter, which ignites the fuel in the combustion flask, where the combination of fuel, air, and water is converted into gases and steam at a high temperature and fed through a pipe to the nozzles of the turbines, furnishing the power for propelling the torpedo.

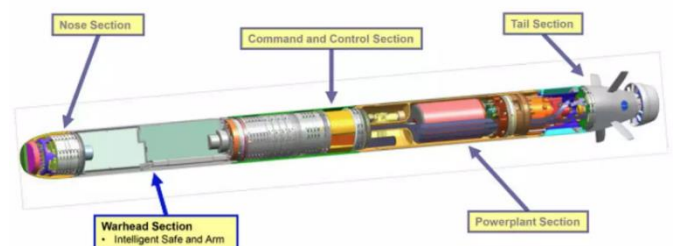

Fig -1: Torpedo sections view

### 3. DESIGN OF TORPEDO

The energy needed to propel a torpedo should overcome the drag and the skin-friction when water flows around the weapon. For maximum efficiency the flow of water should be laminar within the boundary layer or in other words, a streamlined condition should exist. At the rear of the torpedo, the flow along the boundary layer should be gathered in by the propulsion for achieving maximum propulsion efficiency. As a result of the mechanical work done by the propulsion, the water ejected from the stem to give the required thrust. Experiments done in test tanks show that the ideal ratio of length to diameter of a torpedo is 7: 1. Universally, the heavy-weight torpedo has a diameter of 53 cm and to meet the ideal shape, the torpedo's length should be of the order of about 3.5 m. However, the normal length is anywhere between 6 and 7.5 m. Though the designer would like to keep the length near about the. Ideal length, it is impractical to do so as the major sub-assemblies like the warhead, propulsion system, and guidance, have to be accommodated. The requirement of space becomes more stringent as the range increases, owing to increased capacity needed for storing the fuel, oxidant, etc. In the case of light-weight torpedo, the diameter is around 35.2 cm and the length around 4 m.

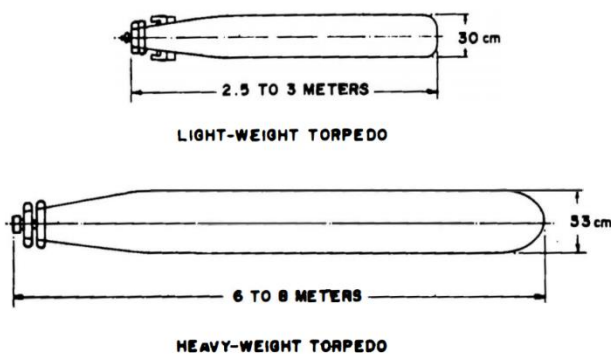

Fig -2: Light-weight and heavy-weight torpedo

If a target is attacked from a long distance, the escape volume for the target also becomes larger if the enemy craft surmises that a torpedo has been launched. In such a situation, the torpedo's terminal homing capability should also be more refined and accurate.

All your designs are stored in the cloud, which means you and your team always access the latest data.

### 4. Linear Buckling

Linear buckling (also called as Eigenvalue buckling) analysis predicts the theoretical buckling strength of an ideal elastic structure. This method corresponds to the textbook approach to elastic buckling analysis: for instance, an Eigen value buckling analysis of a column will match the classical Euler solution. However, imperfections and nonlinearities prevent most real-world structures from achieving their theoretical elastic buckling strength. Thus, linear buckling analysis often yields quick but non-conservative results.

A linear buckling analysis can be performed using the ANSYS solver. Differences between the solvers are noted in the sections below.

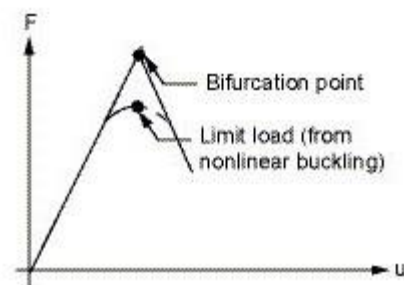

Graph-1: Linear buckling curve

A more accurate approach to predicting instability is to perform a nonlinear buckling analysis. This involves a static structural analysis with large deflection effects turned on. A gradually increasing load is applied in this analysis to seek the load level at which your structure becomes unstable. Using the nonlinear technique, your model can include features such as initial imperfections, plastic behavior, gaps, and large-deflection response. In addition, using deflection-controlled loading, you can even track the post-buckled performance of your structure (which can be useful in cases where the structure buckles into a stable configuration, such as "snap-through" buckling of a shallow dome).

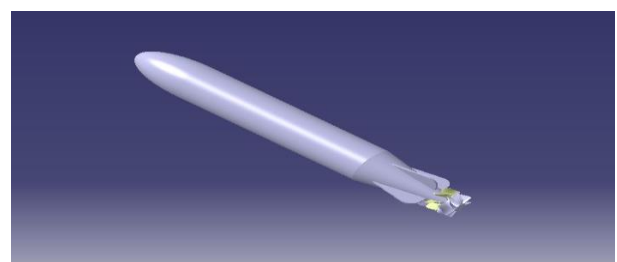

Fig -3: assembled model of the Atlas Torpedo

### 5. Material and construction of Torpedo

Torpedo's are made from corrosion resistant materials as they are made operational directly in sea water which is a corrosion accelerator. The materials used for making Torpedos are alloy of aluminium and stainless steel. Other materials used are alloys of nickel, aluminium and bronze which are 10~15 % lighter than other materials and have higher strength.

### 6. STATIC STRUCTURAL ANALYSIS

MODEL	DEFORMATION (mm)	EQUIVALENT STRESS (Mpa)	EQUIVALENT STRAIN
Atlas	0.22257	8.0091	0.00011323

Table -1: Comparison results

#### Structural Analysis on Atlas

Mass=1503.5 kg, Nodes 13159, Elements=3025.

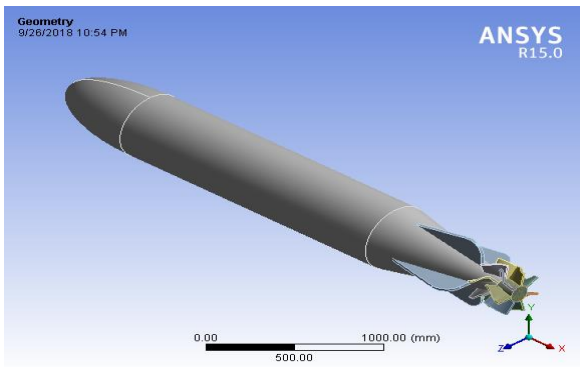

Fig-4: Geometry Diagram

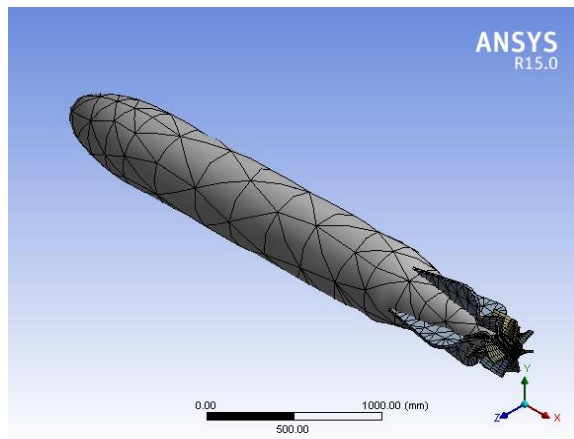

Fig -5: Mesh diagram

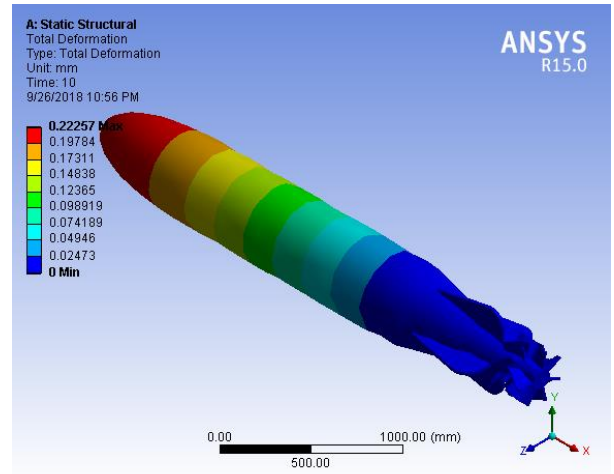

Fig -6: Total deformation

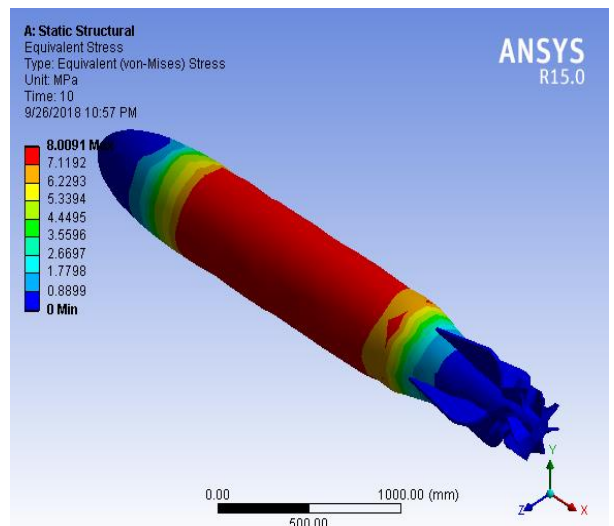

Fig -7: Equivalent stress

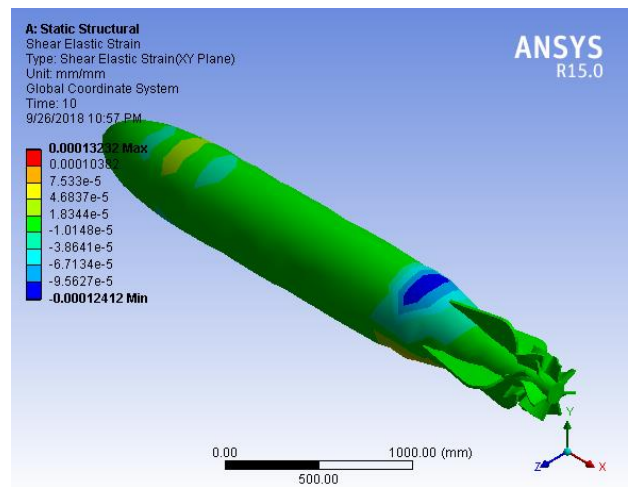

Fig -8: Shear Elastic strain

### 7. LINEAR BUCKLING ANALYSIS

Table -2: Linear Buckling results for Atlas

Force (N)	Total deformation (mm)
0	0
0.8	0.13777
1.6	0.27555
2.4	0.41332
3.2	0.5511
4	0.68887
4.8	0.82665
5.6	0.96442
6.4	1.1022
7.2	1.24

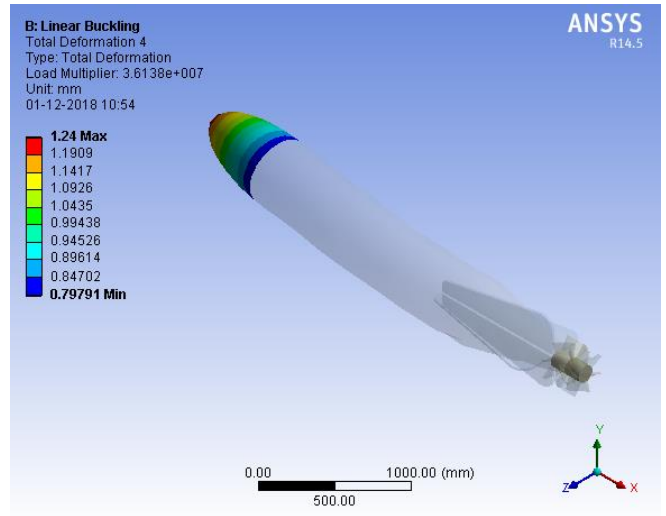

Fig-11: Total deformation on War head

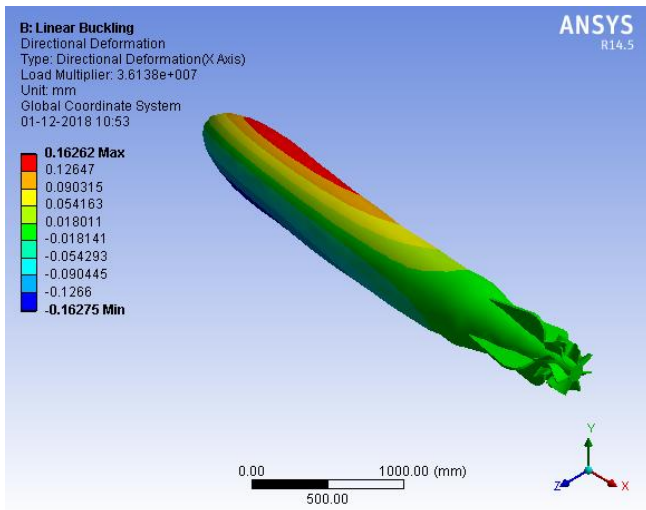

Fig-9: Directional deformation

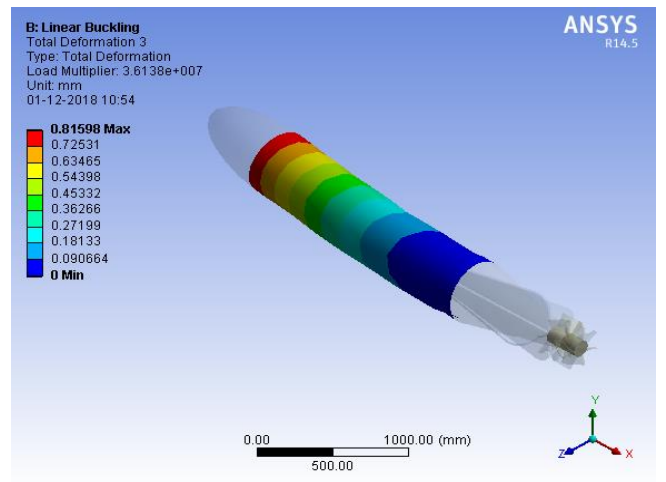

Fig-12: Total deformation on Energy section

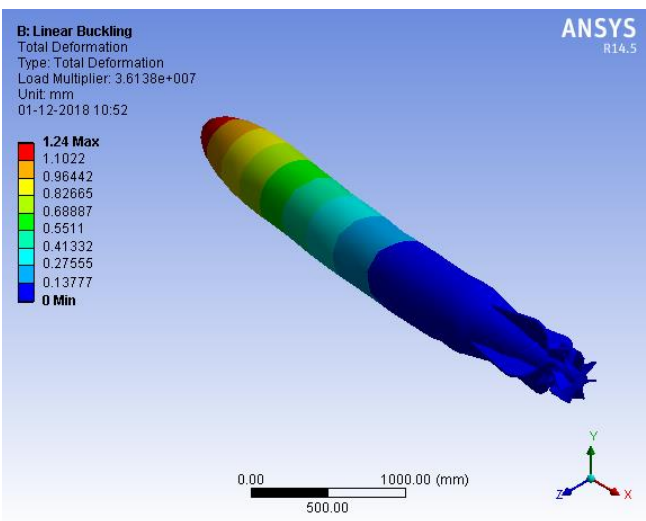
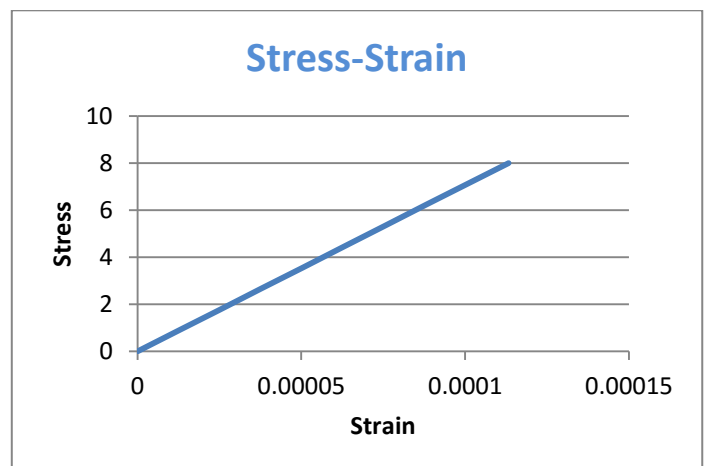
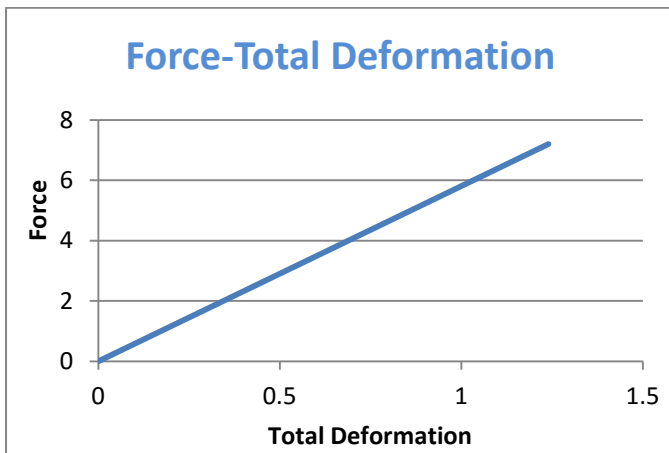

Fig-10: Total deformation



Graph-2: Stress & Strain for Atlas



Graph-3: Force & Total Deformation for Atlas

## CONCLUSIONS

In our paper we have designed Atlas torpedo. The three dimensional Atlas torpedo is designed by using CATIA V5R20 and we created structural analysis Linear buckling analysis using Aluminum Alloy material.

The buckling analysis of the columns with Torpedo cross sectional shapes Tail Section in fixed free conditions. The critical buckling loads of each column made with same material are calculated by using Euler's equation. To keep the Torpedo structure safe the conservative buckling load is considered which is lesser than the calculated critical loads. This conservative load is applied to all the columns axially and compared the results by using ANSYS.

It is observed that, as we go on increasing the number of nodes the total deformation goes on increasing drastically. We can say that maximum Deformation is obtained in linear elastic buckling. Deformation, displacement and stress are observed to be maximum at free end rather than constrained end.

## REFERENCES

- [1] Pothuraju. V.V. Satyanarayana, A. Vamsi Krishna, Design and Structural Analysis of Torpedo[J]. International Research Journal of Engineering and Technology (IRJET),2018,(in India)
- [2] LIU Haijun. The integrated design of torpedo shell structure[J]. Torpedo Technology, 1995, (1): 10- 14(in Chinese).
- [3] SONG Baowei, ZHANG Yuwen, XU Demin. Fuzzy optimization design of torpedo shell structure based on

reliability[J]. Mechanical Science and Technology, 1998, 17(4): 560-562.

[4] SONG Baowei, XU Demin, ZHANG Yuwen. Multiobjective fuzzy weight optimization design of underwater vehicle shell structure[J]. Journal of Northwestern Polytechnical University, 1999, 17(2): 274-279(in Chinese).

[5] PARKINSON A. Robust mechanical design using engineering models[J]. Journal of Mechanical Design, 1995, 117: 48-54.

[6] BUCK R J, WYNN H P. Optimization strategies in robust engineering design and computer aided design[J]. Quality and Reliability Engineering International, 1993(9): 34-48.

## BIOGRAPHY



**Mr. POTHURAJU.V.V.SATYANARAYANA**  
Assistant Professor in Avanthi Institute of Engineering and Technology, Makavarepalem, Visakhapatnam, INDIA. Areas of Interest in Machine Design and Aerospace Research