

# Enhancement Performance of Polymer High Voltage Insulators Using Nano-Filler

Noha Anwer<sup>1</sup>, Loai Nasrat<sup>2</sup>, Abdallah Ibrahim<sup>2</sup>

<sup>1</sup>Electrical Power and Machines Eng. Dept., The High Institute of Engineering and Technology El-Tud, Luxor, EGYPT

<sup>2</sup>Electrical Power and Machines Eng. Dept., Aswan University, Aswan, EGYPT.

\*\*\*

**Abstract** - The rubber and epoxy are polymeric materials and are widely used as insulating materials for many reasons such as; economy, strength and ease fabrication to good tolerance. As a result of the development which has taken place recently; these materials can be produced with various design and shapes for outdoor with suitable electrical and mechanical properties according to their intended purpose. Epoxy Composites are one of Polymeric composite insulators which are used in outdoor Insulation. In order to study the electrical behavior of epoxy composites as outdoor insulators for overhead transmission lines at different conditions, Inorganic fillers such as silica with different size are inserted into the epoxy to modify the electrical and physical properties in addition to maximize surface flashover voltage at dry weather and contaminated weather for composite insulator. The objective of this research is to study electrical properties of epoxy composites which include inorganic filler at different size and concentration as insulators for overhead transmission lines under contaminated weathers to get the suitable polymer composite insulator. This polymer composite insulator achieves the maximum surface flashover voltage.

**Keywords:** Flashover, Polymeric composite, Micro-filler, Nano-filler, Insulators

## 1. INTRODUCTION

All polymer properties are changed by incorporation of reinforcement or filler particles in to composite. The basic types of properties affected by fillers and consolidations are classified to electrical, thermal, mechanical and optical properties. Some processes of polymer inserted in material preparation are divided by spraying, centrifugal casing, gravitational, pressing and selective laser sintering. The varying amount of filler was designed and then fabricated by pressing, gravity and centrifugal casting methods. Properties such as magnetic induction, electrical surface resistivity, and coefficient of friction were tested and analysed. Additionally the distribution of filler particles in polymeric matrix was investigated [1].

Polymeric insulating materials have many of advantages over porcelain, its includes light weight due to lower density, Pollution performance due to have low surface energy and resist wetting, The manufacturing process takes a short time and low maintenance cost. The limitations of polymeric insulating materials are weathering degradation, high cost of raw material and lower mechanical strength [2-7]. Epoxy resins were first

commercialized from seventy year and are widely used in industry as protective coatings and for structural applications, such as laminates and composites, tooling, molding, casting, bonding and adhesives, and others. The ability of the epoxy ring to react with a variety of substrates gives the epoxy resins versatility [8]. Epoxy resins are thermosetting polymers that are widely used in adhesives, paints, coatings, medical implants, and electrical systems. Epoxies are ideal for these applications because of their high specific stiffness, high specific strength, electrical insulating properties, corrosion resistance, chemical compatibility with reinforcing fibres, and relative ease of manufacture [9].

Epoxy resins are used in industry as adhesives and matrix resins for fiber reinforced composite materials where advantage is taken of favorable properties such as high modulus, low creep and reasonable elevated temperature performance. The desirable high glass transition temperatures of epoxy thermosets are largely attributed to their crosslink density [10].

The electrical and mechanical properties of epoxy are improved when the inorganic filler is loaded with epoxy. A wide range of polymer matrices is covered in this review, with special emphasis on biodegradable polymers. In general, polymer/layered silicate Nano composites are of three different types; intercalated Nano composites, flocculated Nano composites and exfoliated Nano composites. This new family of composite materials frequently exhibits remarkable improvements of material properties when compared with the matrix polymers alone or conventional micro and macro composite materials [11].

It is commonly known as Aerosil. Aerosil is highly dispersed, amorphous, very pure silicon that is manufactured by high -temperature hydrolysis of silicon tetrachloride in an oxy -hydrogen gas flame. It is a white, fluffy powder consisting of spherically shaped primary particles. The average particle size is in the range of 7-15 nm and the specific surface area rang between 50 and 380m<sup>2</sup>/g. In contrast to the precipitated silicon it does not have a lucidly defined agglomerate size. Particle size distributions become wider and the tendency to form agglomerates is reduced. Silanol and siloxane groups are Situated on The surface of the fumed silicon particles. Silanol is responsible for hydrophilic behavior, which determines the interaction of the particle with solids, liquids and gases. The surface of the particles can be simplicity rectified by reacting the silanol group with different silanes and silazanes, resulting hydrophobic particles.

## 2. PREPARATION OF COMPOSITES EPOXY

Epoxy composites were prepared by mixing the epoxy and hardener with ratio (3:1 wt. /wt.) for 3 minutes. Filler is added to the resin /hardener mixture which is again stirred slowly till particles have been uniformly mixed with the resin under magnetic field and air bubbles have escaped. The mixture is then poured carefully in glass test tubes and left at room temperature (25°C±1) until curing after 24 hours and 7 days for material stability. The mixture of epoxy composite takes a glass test tubes shape. There are different ratios of filler silica (SiO<sub>2</sub>), in micro and nano size (0.1 up to 7% by weight). The prepared samples of appropriate cylindrical shape (12 mm diameter and 2.5cm length) and insulator shape were molded and left to cure at room temperature overnight and the sample must leave 7 days from completely curing of the sample in the same preparation condition at (25°C ±1). The coding of epoxy composite samples at different concentration of fillers is given in table (1).

**TABLE -1:** Preparation of Epoxy Composite Samples at Different Concentration of Fillers.

Epoxy with different concentration of fillers.	Micro SiO <sub>2</sub>	Nano SiO <sub>2</sub>
		NONE
	10	0.5
	20	3
	30	5
	40	7

## 3. FLASHOVER VOLTAGE TEST

The samples are cleaned with distilled water remove dust and other contaminated particles on the surface prior to the test. Two or three samples are used in each test to check the reproducibility of the results. The voltage was gradually increased at an almost constant rate of 4 KV/sec until the breakdown occurs. The flashover voltage is defined as the maximum voltage that the insulator surface withstands just prior to voltage collapse to a very low voltage accompanied with a large arc current. To check the percentage porosity for the three environmental conditions which have been simulated such as; dry, wet and salty wet.

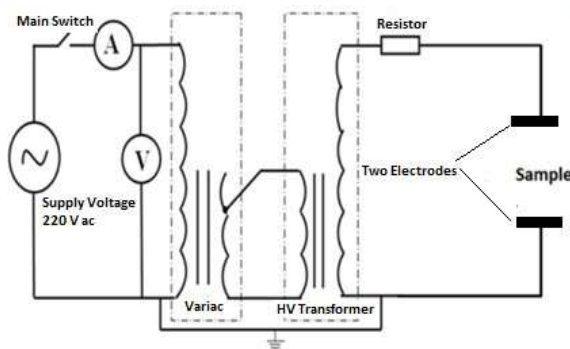

**Fig. 1:** Schematic diagram used for flashover voltage test

## 4. EXPERIMENTAL PROCEDURE

The procedures and precautions required that applied on all samples to obtain on the accuracy reading for each sample during flashover test are as following:

- The samples shall be clean and dry before starting high voltage tests to remove dust and other contaminated particles on the surface prior to the test.
- The time intervals between the voltages applied on each sample shall be suitable and sufficient.
- Ensure that all testing circuit links are correct to apply electrical safety rules.
- The voltage was gradually increased at an almost constant rate of 4kV/sec until the flashover voltage occurs. The flashover voltage is defined as the maximum voltage that the insulator surface has withstood just prior to voltage collapse to a very low voltage accompanied with a large arc current.
- The electrodes are cleaned with a tissue and distilled water at each test.
- The protection circuit is connected with low voltage side to protect the high voltage transformer from the high current at electrical experiment and to clear the short circuit at secondary side within the test by disconnecting the supply on High voltage transformer.

## 5. DISCUSSION OF RESULTS

Many factors have been studied in the present work, these are:

- Dry condition effect.
- Wet condition effect.
- Low Salty wet condition effect.
- Medium Salty wet condition effect.
- High salty wet condition effect.

All of the practical results were precisely gathered and recorded in tabulated forms then plotted to be easily for discussion and analysis.

### Case (a): Study The Flashover Voltage of Epoxy with Different Size of Filler (SiO<sub>2</sub>) in Dry Condition:

**Table-2:** Flashover Voltage (Kv) Of Microcomposite Epoxy Under Dry Condition.

Concentration of micro- filler with epoxy (gm)	Flashover voltage (kV)
0	21.14
10	21.98
20	23.13
30	24.63
40	26.43

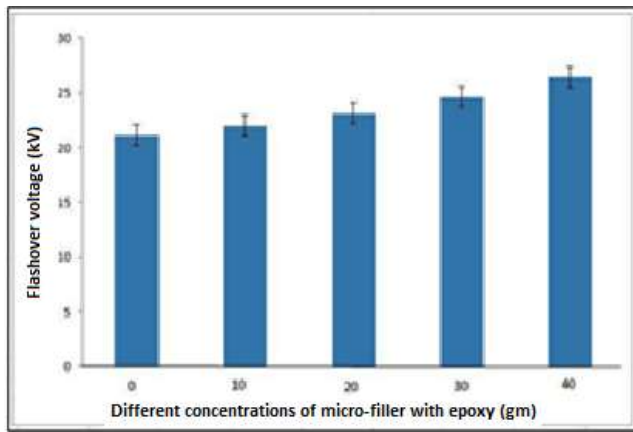

**Fig. 2:** Flashover voltage (kV) of micro-composite epoxy under dry conditions

From the data recorded in table (2) and Fig (2), it can be seen that, pure epoxy has the minimum value of flashover voltage (21.14 kV). While epoxy with (40 gm) of micro-filler SiO<sub>2</sub> has the maximum value of flashover voltage (26.43kV). As the amount of micro-filler SiO<sub>2</sub> increases, the flashover voltage increases, it may be due to the cross-linked between the molecules of epoxy is making a good bond inside the structure. Fig (3) curve fitting for the flashover voltage results for micro-composite epoxy under dry condition. From the calculation of the program the best curve fitting for the data obtained can be represented by square degree polynomial equation as follows:

$$Y=A +BX+C$$

where Y is the flashover voltage under dry condition value,

X is the concentration of micro-filler (SiO<sub>2</sub>). A is a constant = 0.0016

B is a constant = 0.067 C is a constant = 21

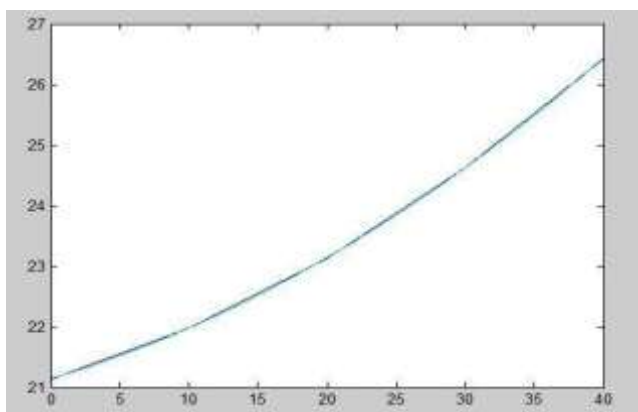

**Fig. 3:** Curve fitting results for the flashover voltage of micro composite epoxy under dry condition

**Table-3:** Flashover voltage (kV) of nano-composite epoxy under dry condition.

Concentration of nano-filler with epoxy (gm)	Flashover voltage (kV)
0	21.14
0.5	21.98
3	23.13
5	24.63
7	26.43

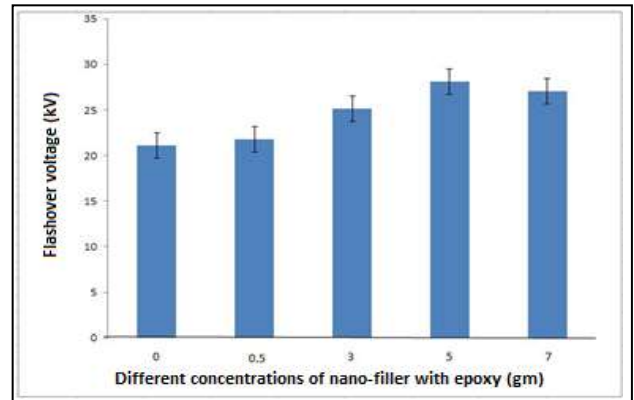

**Fig. 4:** Flashover voltage (kV) of nano-composite epoxy under dry conditions

From the data recorded in table (3) and Fig (4), it can be seen that, pure epoxy has the minimum value of flashover voltage (21.14 kV). While epoxy with (5gm) of nano-filler SiO<sub>2</sub> has the maximum value of flashover voltage (28.14kV). As the amount of nanofiller SiO<sub>2</sub> increases from (0gm) to (5gm), the flashover voltage increases, it may be due to the crosslinked between the molecules of epoxy is making a good bond inside the structure. But at (7gm) the flashover voltage decreases, due to epoxy would reached to the saturation. Fig (5) curve fitting for the flashover voltage results for micro-composite epoxy under dry condition.

From the calculation of the program the best curve fitting for the data obtained can be represented by 4<sup>th</sup> degree polynomial equation as follows:

$$Y=A +B +C +DX+E$$

where Y is the flashover voltage under dry condition value, X is the concentration of nano-filler (SiO<sub>2</sub>).

A is a constant = -0.011

B is a constant = 0.092

C is a constant = -0.15

D is a constant = 1.3

E is a constant = 21

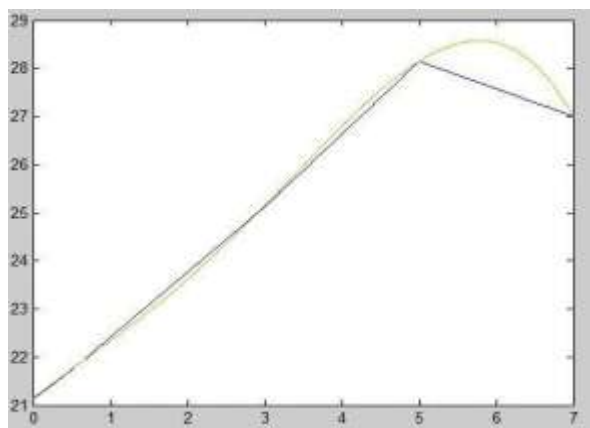

Fig. 5 :Curve fitting results for the flashover voltage of nanocomposite epoxy under dry condition.

**Case (b): Study The Flashover Voltage of Epoxy with Different Size of Filler (SiO2) in Wet Condition.**

The studies carried out in this work lead to know the effect of water on flashover voltage of composite epoxy.

**Table -4:** Flashover voltage (kV) of micro-composite epoxy under wet condition

Concentration of micro-filler with epoxy (gm)	Flashover voltage (kV)
0	18.33
10	19.46
20	21.04
30	22.33
40	24.04

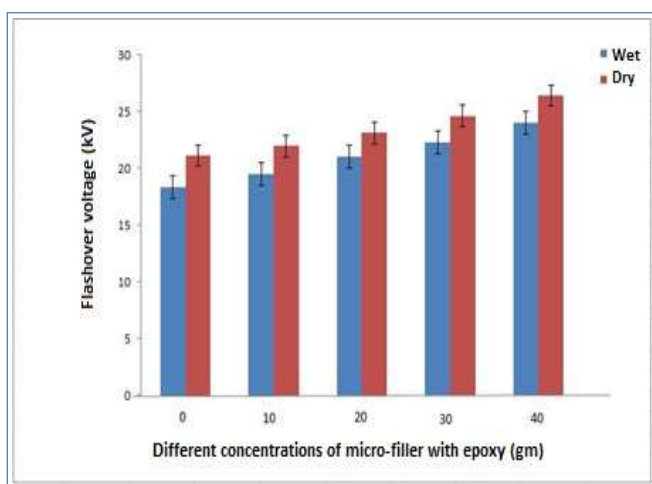

Fig. 6:Flashover voltage (kV) of micro-composite epoxy under wet conditions

It can be noticed from Fig (6) that, the flashover voltage of pure epoxy decreases from 21.14 kV for dry case to 18.33 kV for wet condition. The flashover voltage of micro SiO2 (10gm) decreases from 21.98 kV for dry case to 19.46 kV for wet condition. The flashover voltage of micro SiO2 (20gm) decreases from 23.13 kV for dry case to 21.04 kV

for wet condition. The flashover voltage of micro SiO2 (30gm) decreases from 24.63kV for dry case to 22.33 kV for wet condition. The flashover voltage of micro SiO2 (40gm) decreases from 26.43 kV for dry case to 24.04 kV for wet condition. The comparison between the flashover voltage for samples in wet and dry condition led us to know water effect on the sample. The flashover voltage decreased in wet condition as compared with those in dry condition. This is due to the degradation of samples which are affected by water. Fig(7) curve fitting for the flashover voltage results for the samples under wet condition. From the calculation of the program the best curve fitting for the data obtained can be represented by cubic degree polynomial equation as follow:

$$Y=A +B +CX+D$$

where Y is the flashover voltage under wet condition value,

X is the concentration of nano-filler (SiO2).

A is a constant = -5E-0.6

B is a constant = 0.00096

C is a constant = 0.11

D is a constant = 18

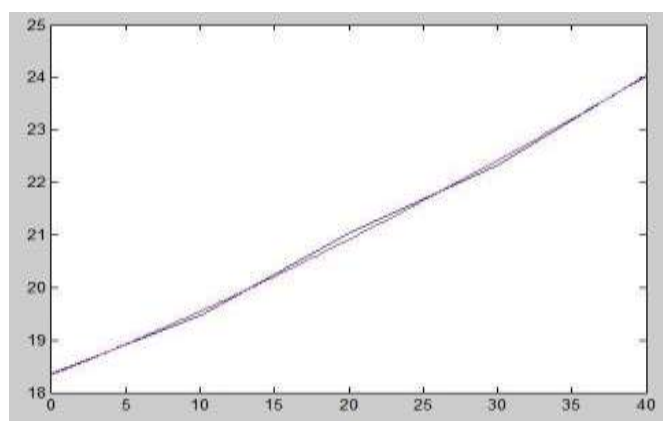
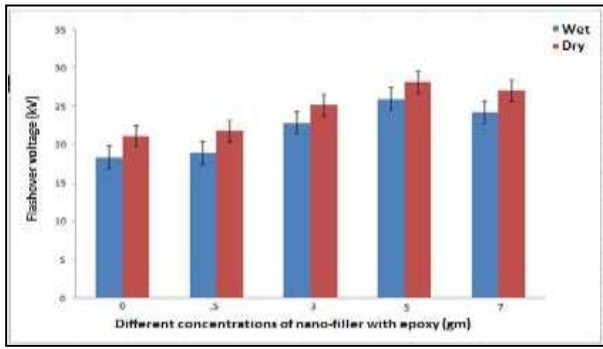

Fig. 7 :Curve fitting results for the flashover voltage of micro-composite epoxy under wet condition.

**Table -5:** Flashover voltage (kV) of nano-composite epoxy under wet condition.

Concentration of nanofiller with epoxy (gm)	Flashover voltage (kv)
0	18.33
0.5	18.92
3	22.82
5	25.95
7	24.22





**Fig. 8:** Flashover voltage (kV) of nano-composite epoxy under wet conditions.

It can be noticed from Fig (8) that, the flashover voltage of pure epoxy decreases from 21.14 kV for dry case to 18.33 kV for wet condition. The flashover voltage of nano SiO<sub>2</sub> (0.5gm) decreases from 21.74 kV for dry case to 18.92 kV for wet condition. The flashover voltage of nano SiO<sub>2</sub> (3gm) decreases from 25.14 kV for dry case to 22.82 kV for wet condition. The flashover voltage of nano SiO<sub>2</sub> (5gm) decreases from 28.14 kV for dry case to 25.95 kV for wet condition. The flashover voltage of nano SiO<sub>2</sub> (7gm) decreases from 27.01 kV for dry case to 24.22 kV for wet condition. The comparison between the flashover voltage for samples in wet and dry condition led us to know water effect on the sample. The flashover voltage decreased in wet condition as compared with those in dry condition. This is due to the degradation of samples which are affected by water.

Fig (9) curve fitting for the flashover voltage results for nano-composite epoxy under wet condition.

From the calculation of the program the best curve fitting for the data obtained can be represented by 4<sup>th</sup> degree polynomial equation as follows:

$$Y=A +B +C +DX+E$$

where Y is the flashover voltage under wet condition value, X is the concentration of nanofiller (SiO<sub>2</sub>).

A is a constant = -0.0098 B is a constant = 0.058  
 C is a constant = -0.029 D is a constant = 1.2  
 E is a constant =18

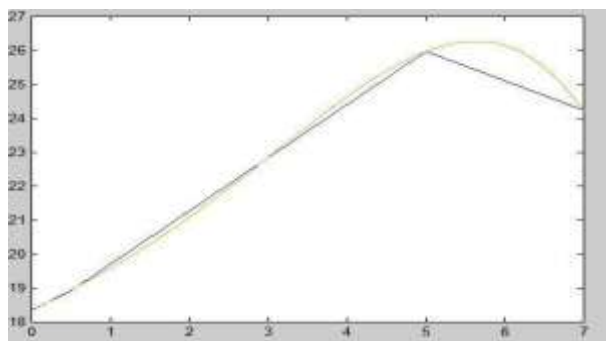

**Fig. 9 :** Curve fitting results for the flashover voltage of nano-composite epoxy under wet condition

**Case (c): Study the Effect of Different Salinities on the Flashover Voltage of Epoxy with Different Size of Filler (SiO<sub>2</sub>).**

Electrolysis of saline pollution results in the formation of NaOH. So the most likely form of alkali to be encountered by organic insulation located near the sea coast would be NaOH, the samples were tested under the reagent of NaOH to evaluate the flashover voltage. The artificial pollution is prepared by mixing NaCl with distilled water. The samples are polluted properly by salt solution after immersed them in NaCl solution for 24hr.

In the experiment, three different salinities (20000µS/cm, 30000 µS/cm and 50000 µS/cm) was obtained by adding percentages of NaCl to the water. The existence of NaOH drastically affected all samples.

**Table-6:** Flashover voltage (kV) of micro-composite epoxy under different salinities condition.

Concentration of micro-filler with epoxy (gm)	Flashover voltage (kV)			
	Dry	20000 µS/cm	30000 µS/cm	50000 µS/cm
0	21.14	17.17	14.67	13.02
10	21.98	18.02	15.11	13.96
20	23.13	20.66	17.46	15.84
30	24.63	21.91	18.67	16.99
40	26.43	23.52	20.09	18.38

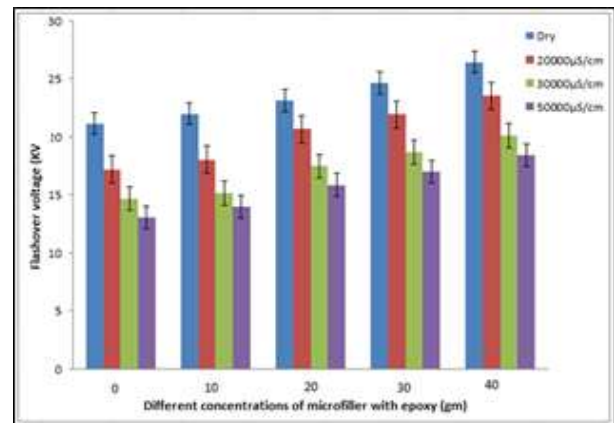

**Fig. 10:** Flashover voltage (kV) of micro-composite epoxy under different salinities conditions

Figure (10) and table (6) illustrates the following: As the amount of micro-filler SiO<sub>2</sub> increases the flashover voltage increases in all salinities (20000µS/cm, 30000µS/cm and 50000µS/cm).

The flashover voltage of pure epoxy decreases from 21.14 kV for dry case to 17.17 kV for 20000µS/cm and to 14.67 kV for 30000µS/cm and to 13.02 kV for 50000µS/cm. The flashover voltage at (10gm) decreases from 21.98 kV for dry case to 18.02 kV for 20000µS/cm and to 15.11 kV for 30000µS/cm and to 13.96 kV for 50000 µS/cm. The flashover voltage at (20gm) decreases from 23.13 kV for dry case to 20.66 kV for 20000µS/cm and to 17.46 kV for

30000 $\mu$ S/cm and to 15.84 kV for 50000  $\mu$ S/cm. The flashover voltage at (30gm) decreases from 24.63 kV for dry case to 21.91 kV for 20000 $\mu$ S/cm and to 18.67 kV for 30000 $\mu$ S/cm and to 16.99 kV for 50000  $\mu$ S/cm. The flashover voltage at (40gm) decreases from 26.43 kV for dry case to 23.52 kV for 20000 $\mu$ S/cm and to 20.09 kV for 30000 $\mu$ S/cm and to 18.38 kV for 50000  $\mu$ S/cm. The flashover voltage will decrease by increasing concentrations of NaCl solution.

The surface of samples is improved by increasing the amount of micro-filler (SiO<sub>2</sub>). And it leads to increasing the flashover voltage.

**Table-7:** Flashover voltage (kV) of micro-composite epoxy under different salinities condition.

Concentration of nano-filler with epoxy (gm)	Flashover voltage (kV)			
	Dry	20000 $\mu$ S/cm	30000 $\mu$ S/cm	50000 $\mu$ S/cm
0	21.14	17.17	14.67	13.02
0.5	21.74	17.64	15.03	13.31
3	25.14	22.08	20.34	17.14
5	28.14	25.07	21.98	19.87
7	27.01	23.81	20.92	18.59

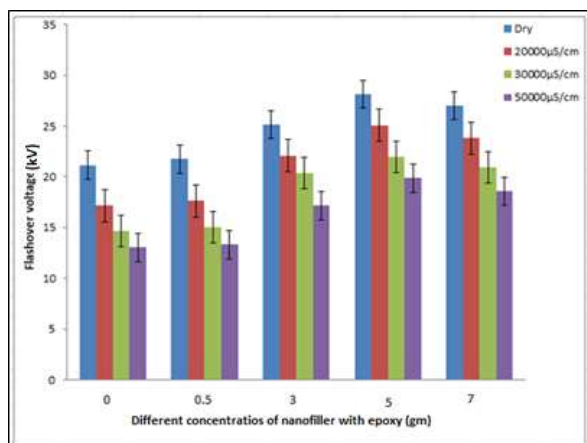

**Fig. 11:** Flashover voltage (kV) of nano-composite epoxy under different salinities conditions

Figure (11) and table (7) illustrates the following: As the amount of nano-filler SiO<sub>2</sub> increases from 0gm to 5gm the flashover voltage increases in all salinities (20000 $\mu$ S/cm, 30000 $\mu$ S/cm and 50000 $\mu$ S/cm).

The flashover voltage of pure epoxy decreases from 1.14 kV for dry case to 17.17 kV for 20000 $\mu$ S/cm and to 14.67 kV for 30000 $\mu$ S/cm and to 13.02 kV for 50000  $\mu$ S/cm. The flashover voltage at (10gm) decreases from 21.74 kV for dry case to 17.64 kV for 20000 $\mu$ S/cm and to 15.03 kV for 30000 $\mu$ S/cm and to 13.31 kV for 50000  $\mu$ S/cm. The flashover voltage at (20gm) decreases from 25.14 kV for dry case to 22.08 kV for 20000 $\mu$ S/cm and to 20.34 kV for 30000 $\mu$ S/cm and to 17.14 kV for 50000  $\mu$ S/cm. The flashover voltage at (30gm) decreases from 28.14 kV for dry case to 25.07 kV for 20000 $\mu$ S/cm and to

21.98 kV for 30000 $\mu$ S/cm and to 19.87 kV for 50000  $\mu$ S/cm. The flashover voltage at (40gm) decreases from 27.01 kV for dry case to 23.81 kV for 20000 $\mu$ S/cm and to 20.92 kV for 30000 $\mu$ S/cm and to 18.59 kV for 50000  $\mu$ S/cm. The flashover voltage will decrease by increasing concentrations of NaCl solution.

The surface of samples is improved by increasing the amount of nano-filler (SiO<sub>2</sub>) from 0gm to 5gm. And it leads to increasing the flashover voltage.

## 6. COMPARISON BETWEEN MICRO/NANO FILLER WITH EPOXY

In a way to describe both micro/nanofiller (SiO<sub>2</sub>) and plot them simultaneously, per unit technique (pu) shall be used and applied to micro/ nano-composites epoxy results 40gm is taken to be the base value for all concentrations of micro-filler with epoxy investigated in this thesis under dry, wet and salt wet conditions; as it is considered the maximum weight of micro-filler in the samples recorded in our study. Table (8) comprises the concentrations of micro-filler samples dry, wet and salt wet conditions. Similarly, 7gm is taken to be the base value for all concentrations of nano-filler with epoxy investigated in this thesis under dry, wet and salt wet conditions; as it is considered the maximum weight of nano-filler in the samples recorded in our study. Table (8) comprises the concentrations of nano-filler samples under dry, wet and salt wet conditions.

**Table-8:** Per unit values of micro/nano-filler (SiO<sub>2</sub>).

Actual value of microfiller (gm)	Per unit value of microfiller (pu)	Actual value of nanofiller (gm)	Per unit value of nanofiller (pu)
0	0	0	0
10	0.25	0.5	0.07
20	0.5	3	0.43
30	0.75	5	.71
40	1	7	1

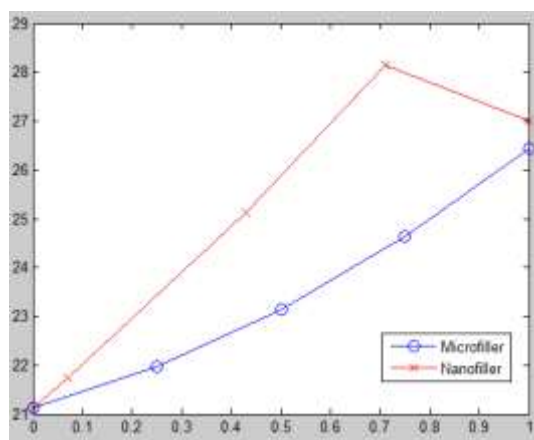

**Fig. 12 :** Flashover voltage of micro/nano-composite epoxy under dry condition.

It can be noticed from Fig (12) that, The comparison between the flashover voltage for samples in

microcomposite epoxy and nano-composite epoxy led us to know the flashover voltage decreased in nano-composite epoxy as compared with those microcomposite epoxy. Also the flashover voltage increased, when the size of filler (SiO<sub>2</sub>) with epoxy decreased under dry condition.

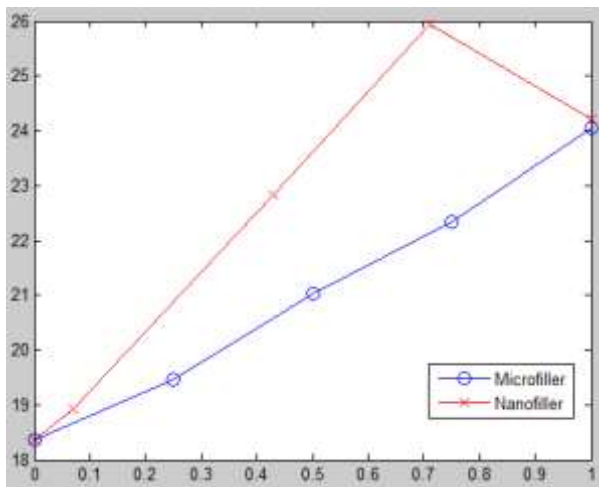

**Fig. 13 :** Flashover voltage of micro/nano-composite epoxy under wet condition

It can be noticed from Fig (13) that, The comparison between the flashover voltage for samples in micro-composite epoxy and nano-composite epoxy led us to know the flashover voltage decreased in nano-composite epoxy as compared with those micro-composite epoxy. Also the flashover voltage increased, when the size of filler (SiO<sub>2</sub>) with epoxy decreased under wet condition.

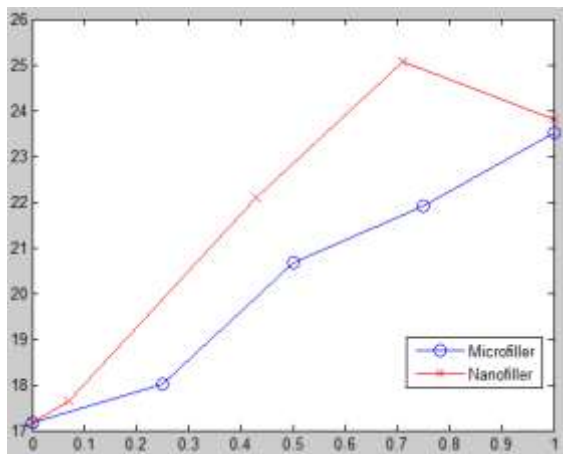

**Fig. 14 :** Flashover voltage of micro/nano-composite epoxy under salinity(20000µS/cm) condition.

It can be noticed from Fig (14) that, The comparison between the flashover voltage for samples in microcomposite epoxy and nano-composite epoxy led us to know the flashover voltage decreased in nano-composite epoxy as compared with those microcomposite epoxy. Also the flashover voltage increased, when the size of filler (SiO<sub>2</sub>) with epoxy decreased under salinity (20000µS/cm) condition.

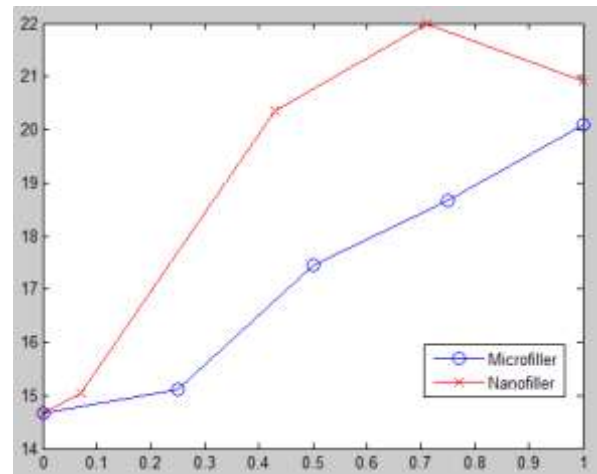

**Fig. 15 :** Flashover voltage of micro/nano composite epoxy under salinity(30000µS/cm) condition

It can be noticed from Fig (15) that, The comparison between the flashover voltage for samples in micro-composite epoxy and nano-composite epoxy led us to know the flashover voltage decreased in nano-composite epoxy as compared with those micro-composite epoxy. Also the flashover voltage increased, when the size of filler (SiO<sub>2</sub>) with epoxy decreased under salinity(30000µS/cm) condition.

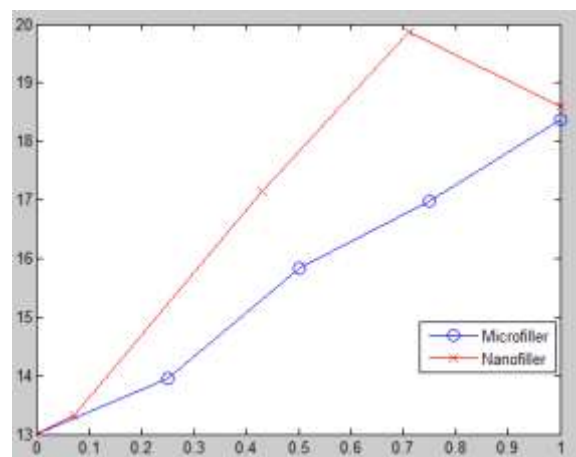

**Fig. 16 :** Flashover voltage of micro/nano-composite epoxy under salinity(50000µS/cm) condition.

It can be noticed from Fig (16) that, The comparison between the flashover voltage for samples in micro-composite epoxy and nano-composite epoxy led us to know the flashover voltage decreased in nano-composite epoxy as compared with those micro-composite epoxy. Also the flashover voltage increased, when the size of filler (SiO<sub>2</sub>) with epoxy decreased under salinity(50000µS/cm) condition.

## 7. CONCLUSIONS

Electrical properties of epoxy composite filled with nano silica has flashover voltage better than micro silica composite at maximum concentration of each one .The silica nano filler which is used in composite give maximum flashover voltage 27.01 kV for composite material where the

epoxy gives maximum flashover voltage 21.14 kV at dry case. The flashover voltage of epoxy composites increases if the micro filler concentration increases. The flashover voltage of epoxy composite material is lower than microcomposite and nano-composite.

The Flashover voltage of micro silica composite insulator is maximum (24.63kV) and also is minimum (21.98kV) at dry weather if the filler concentration is changed in 10gm and 40gm respectively. The Flashover voltage of nano silica composite insulator is maximum (21.74kV) and also is minimum (27.01kV) at dry weather if the filler concentration is changed in 0.5gm and 5gm respectively. Finally, the nano silica filler improves the electrical properties of epoxy composites and increase the flashover voltage of composites.

of Epoxy Polymers and Their Composites ",Journal of Polymer Science, Part B: Polymer Physics 49, Vol. 24, pp.1695-1716, 2011.

[10] C. A. May, "Modifications of Epoxy Resins with Functional Hyperbranched", Epoxy Resins Chemistry and Technology, 2nd edition, Marcel Dekker, Inc., New York, 1988.

[11] S. R. Suprakas, O. Masami, "Polymer/layered silicate nanocomposites: a review from preparation to processing", Polymer Science, Vol. 28, pp. 1539-1641, 2003.

## REFERENCES

- [1] J. Stabic, A. Dybowska, M. Chomiak , "Polymer composites filled with powders as polymer grade Materials", journal of Achievements in materials and manufacturing engineering Vol. 43, No.1, pp.153-161, 2010.
- [2] J.Mackevich and M.Shah, "Polymer Outdoor Insulating Materials Part 1: Comparison of Porcelain and Polymer Electrical Insulation", IEEE Electrical Insulation Magazine, Vol.13, No.3, PP. 5-12, May-June 1997.
- [3] E.A.Cherney, "Non-ceramic Insulators- A simple Design that Requires Careful Analysis", IEEE Electrical Insulation Magazine, Vol. 12, No.3, PP.7-15, June 1996.
- [4] R.S Gorur, E.A Cherney, and R.Hackam, "the AC and DC Performance of Polymeric Insulating Materials Under Accelerated Ageing in A fog Chamber", IEEE Trans. on Power Delivery, Vol. 3, No.4, PP. 1892-1902, Oct. 1988.
- [5] R.S Gorur, J.W. Chang and O.G. Amburgey, "Surfac Hydrophobicity of Polymers Used for Outdoor Insulation", IEEE Trans. on Power Delivery, Vol. 5, No.4, PP. 1923-1933, Oct. 1990.
- [6] S.M.Gubanski, "Properties of Silicone Rubber Housings and Coatings", IEEE Trans. on Electrical Insulation, Vol. 27, No.2, PP. 374-382, Apr. 1992.
- [7] L.Xidong, W.Shaowu, F.Ju, and G.Zhicheng, "Development of Composite Insulators in China", IEEE Trans. on Dielectrics and Electrical Insulation, Vol. 6, No.5, PP. 586-594, Oct. 1999.
- [8] L. V. McAdams, J. A. Gannon, "High Performance Polymers and Composites", J. I. Kroschwitz edition, John Wiley & Sons, Inc., pp 258-318, 1991.
- [9] G. M. Odegard, A. Bandyopadhyay, "Physical Aging