

Design and performance evaluation of a NARO forage chopper prototype for smallholder dairying systems

Kiggundu Muhammad¹, Kato Hussein Walusimbi², Komakech Jimmy³, Mugerwa Swidiq⁴

^{1,2,3,4}National Agricultural Research Organization-National Livestock Resources Research Institute, P. O. Box 5704, Kampala, Uganda

Abstract - Feeding dairy cattle un-chopped forages is associated with selective feed consumption and high feed wastage. Although majority of farmers still rely on the use of rudimentary implements notably the panga for chopping forage, use of such implements is time consuming and is associated with drudgery and health hazards. In this article, we describe the process of designing, fabrication and evaluation of a low-cost forage chopper used to chop forages to reduce drudgery associated with the use of rudimentary chopping implements. The forage chopper prototype consists of a 7.0 horse power water cooled diesel engine, connected to cutting blades in a cutting chamber via a shaft and coupling joint. We tested and evaluated the chopper prototype using different forages. Averagely, the machine was capable chopping 859.3 kilograms per hour. The average length of the chopped materials was 2.9 cm and 2.1 cm for Napier grass and maize, respectively. The average estimated cost of the chopper was 882.6 USD compared with average cost (1,184.2 USD) of imported choppers with diesel engines of similar horsepower, implying that farmer could save up to 301.6 USD at the time of purchasing the chopper.

Key Words: Forage chopper, performance evaluation, smallholder dairy, Uganda

1. INTRODUCTION

Napier grass (*Pennisetum purpureum*) constitute the dominant forage-based feed resource fed to dairy cattle under zero-grazing systems in East Africa (Lukuyu et al., 2012). The forage is normally offered to dairy cattle in un-chopped or inappropriately chopped form (Kiyimba, 2011) leading to significant feed wastage attributed partly to selection of palatable and/or refusal of unpalatable fodder parts by animals (Zemmelink and Mannelje, 2002). Yet, appropriate chopping of fodder has been demonstrated to boost feed intake, lower feed rejection and consequently reduce feed wastage by 50 percent. In an attempt to boost feed utilization efficiency in forage-based dairy feeding systems through minimization of feed wastage, farmers use several farm implements notably pangas (Photo 1), manual

chaff cutters and motorized forage choppers to chop different forage resources. However, the many forage chopping equipment particularly pangas and chaff cutters are associated with several limitations including drudgery, ineffectiveness, and health concerns. Indeed, several farmers have reported loss of fingers during panga-aided forage chopping operations.



Photo-1: Farmer chopping Napier grass using a panga

Also, majority of the forage choppers used in Uganda are imported into the country but the high initial cost of purchase (average USD 1,184.2) coupled with the shortage of after-sales repair and maintenance services discourages farmers from buying the imported machines. In addition, some of the choppers are made from low quality and/or light metal sheets reducing the productive life of the machines. Therefore, in this article we describe the design, development process and performance of a low-cost and effective forage chopper prototype that can be used and operated by smallholder dairy farmers to appropriately and efficiently chop forage resources, boost feed intake, reduce wastage and consequently bolster productivity of small-scale dairying systems.

2. Design and development of the forage chopper prototype

2.1 Design approach

The prototype was designed based on information gathered from a country-wide dairy cattle farmers' survey based on concerns raised by farmers who owned imported and to small extent, locally fabricated forage choppers. From the survey, several concerns were reported by the farmers including the high initial cost of purchase, high equipment vibrations during operation, high rate of machine breakdown, absence of after sales maintenance and repair services; and limited availability of spare parts on the local market. Consequently, the NARO forage chopper was designed and constructed to be a low-cost, hardy and easy to maintain machine that can be operated by even unskilled labor. The critical aspect of the design process included; having a mobile and hardy machine which could be moved from one place to another, that is durable, quality of the chopped materials, efficiency and effectiveness, and high throughput. The prototype was designed for forage chopping purposes only.

2.2 Description of NARO forage chopper prototype

2.2.1. Materials for chopper fabrication

- Square hollow sections: These were made from mild steel with the dimensions of 50×50×2mm
- Circular hollow sections: These were used in fabrication of the handlers to enable pushing the machine from one position to another.
- Plain metallic metal sheets: The metal sheets used were made from mild steel of 3mm thickness.
- Angle lines: These were of two sizes: 50×50×4mm and 70×70×8mm
- Rubber tyres
- Blades: The blades were made from hardened steel of 10mm thickness
- Nuts and bolts: These were of several sizes depending on where the nut and bolt was supposed to be used.
- Shaft: A cylindrical metallic section made from hardened steel with a diameter of 38mm.
- Bearings: Used for holding the shaft in positions and to facilitate rotation of the shaft
- Coupling: Made from hardened steel of 10mm thickness and was used to connect the shaft to the diesel engine

2.2.2. Assembly of chopper operating components

Machine support system: The support system of the machine was designed to provide for adequate anchorage of the machine and to minimize vibration during operation. This system consisted of welded and joined 40 × 40mm mild steel square hollow sections of 4mm thickness. The frame constituted of six stands of either 630 or 750 mm height from the ground. A Mild Steel Angle line 40 ×40mm and thickness of 2mm was then welded on top of the frame and holes were drilled through it to secure the diesel engine in place. Two metallic and rigid handles made from circular hollow sections were welded onto the frame to allow for pushing and pulling of the machine from one place to another. The handles were made to 450mm long and 500 mm from the ground level to minimize the energy required to push or pull the machine. To make the machine mobile, two tyres were placed at the bottom to support the weight of the machine during transportation. The wheels were made from inflatable tubeless rubber material and had a diameter of 340mm. The distance between wheels was about 710mm apart.

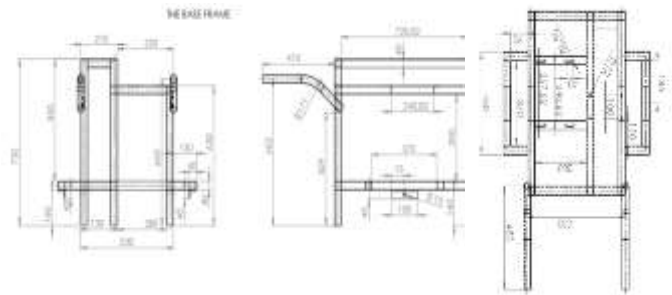

Fig -1: Showing dimensions of the supporting base frame of the prototype

Chopping system: The assembly of the chopping system involved fabricating and joining the metal sheets into a cutting chamber which was composed of two parts: base A (cover) and base B (Figure 2). Base B was then welded onto the main frame of the machine. Similarly, base A (cover of the cutting chamber) was secured on the main frame using hinges. With this design, it would be possible for the operator to open the cutting chamber to inspect the blades prior to start of chopping. Also located on the cover of the cutting chamber (base A), is the provision for attachment of the hopper as well as the hole through which the shaft connects the cutting blades and the power source. The feed hopper was constructed from a 3mm mild steel plate (Figure 3(b)). The hopper has rectangular shape which tapers from the outside to the inside. The hopper was then welded in position and supported at the base by a hollow section connected to cutting chamber. The function of the hopper is to guide feeding of the cutting chamber with the forages. At the

top of discharge chute of the cutting chamber, a flap made from mild steel (Figure 3(a)) was secured in position using bolts and nuts to ensure that it can be adjusted to guide the trajectory of the chopped materials.

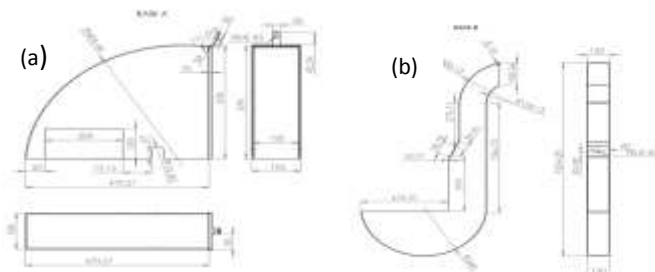

Fig -2: Showing dimensions for the cover (a) and the lower part (b) of cutting chamber of the machine

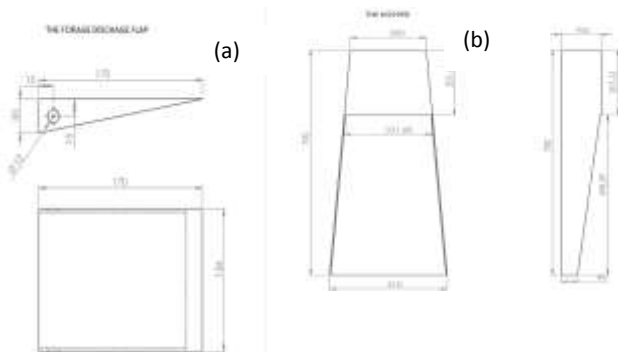

Fig- 3: Showing dimensions of the cutting chamber chute flap (a) and the hopper (b)

After assembling the housing of the cutting chamber, the center bush was inserted into position by hitting it hard up to the center of the shaft. On the center bush, we welded a 70 × 70 × 8mm angle line (Figure 4(a)) and subsequently drilled holes at which the blades (Figure 4(b)) were fastened using counter seal nuts. The shaft with the blades were then aligned in the center of the cutting chamber using two 38mm diameter bearings on either side of the chamber, after which the bearings were secured in place using nuts and bolts. On the side without the hopper, the connection between the shaft and flywheel of the diesel engine was achieved using the coupling joint (Figure 5) and locked in place using a key.

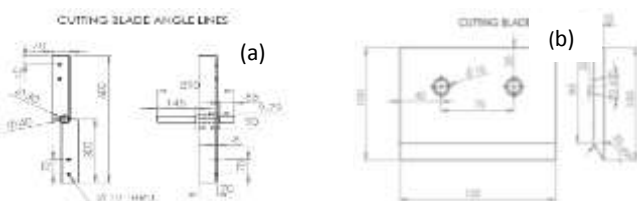

Fig- 4: Showing orientation of the angle lines for mounting blades (a) and dimensions of the cutting blades (b)

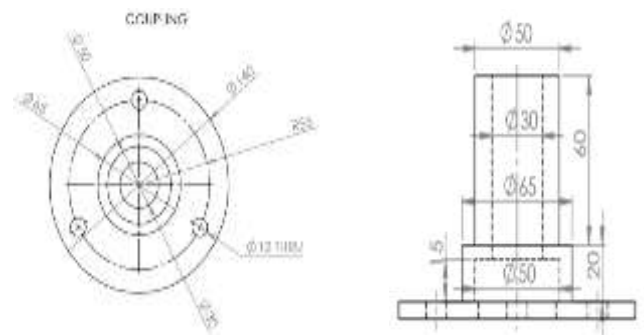

Fig-5: Showing dimensions of the coupling joint used to connect the shaft and flywheel of the diesel engine

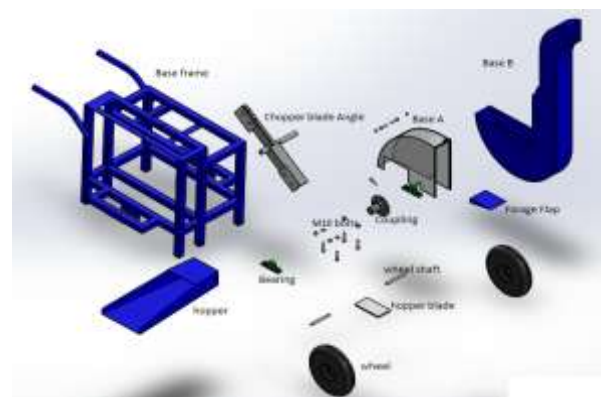

Fig- 6: Showing main components used in assembling of the NARO forage chopper prototype



Photo- 2: Assembled NARO forage chopper prototype

Power system: The chopper is powered by JIANDONG 7.0 horse power water cooled diesel engine. The engine drives the cutting blades through a shaft connected via a coupling joint. The engine has a throttle which allows the operator to moderate the power output and acceleration of the engine. The center bush was secured into position by hitting it hard up to the center of the shaft. On the center bush, we welded the 60×60×8mm angle line and subsequently drilled holes at which the blades were fastened using counter seal nuts.

3.0 Mode of operation of the forage chopper

The chopper is driven by a 7.0 horse power diesel engine which rotates the cutting blades via a coupling joint. The forage is introduced into the machine manually through a hopper by the operator with a slight push of the material into the cutting chamber. After chopping, the material is then blown out of the cutting chamber by the help of the centrifugal force of the cutting blades through the chute. The trajectory of the chopped materials is controlled using an adjustable flap on top of the discharge chute.

4.0 Production cost of the chopper

Table- 1: Costs of production of the NARO forage chopper prototype

	Item	USD*
1	Materials for machine fabrication	269.2
2	Diesel engine	342.1
3	Consumables in machine fabrication	71.6
4	Labor cost	52.6
5	Assuming a gross profit margin (20% of cost of production)	147.1
	Total	882.6

*1 USD= 3,800 Uganda shilling

Performance evaluation of the chopper

To assess the efficiency of the NARO forage chopper prototype in performing the intended purpose, the following criteria was adopted.

- Fuel use efficiency, defined herein as the amount of fuel consumed per kilogram of the chopped forage. Fuel use was measured by initially filling the fuel tank with 4 liters of diesel. After each run, the quantity of fuel used for chopping 10 kg of forage was estimated by draining the fuel tank completely and subsequently measuring the fuel in the tank using a graduated measuring cylinder. The difference between amount of fuel prior to and after chopping was used to estimate fuel use efficiency.
- Throughput, defined herein as the amount of forage chopped per hour when the machine is operating at

optimal capacity (Harry and John, 2007). This was assessed by chopping a known amount of forage in a given time period. The quantity of forages was measured by a digital weighing balance while the time taken was measured using a stop watch.

The performance of the chopper was evaluated using fresh Napier grass and maize fodder. The moisture content of the forages was determined using a forced air oven. For each testing run, a total of 10 kg of fresh forage was weighed using a digital weighing scale. The material was then fed into the cutting chamber of the chopper via the hopper. The chopped materials were then collected in a polyethylene bag before separating the materials to determine the length of the chop. The time taken to chop the 10 kg quantity of Napier grass was recorded using a stop watch. A total of three test runs were made in order to obtain an average measure of the performance parameters. The amount of fuel consumed for chopping the 10 kg forage was determined by draining the fuel tank of the machine and estimating the volume using a calibrated measuring cylinder.

5.0 Results and discussion

The prototype was tested using Napier grass and maize fodder and the results are presented in table 2 below.

Table 2: Performance evaluation of the prototype

Forage type	Napier grass	Maize fodder	SEM	P value
Fuel use efficiency (kg/liter)	973.2	983.6	7.3	ns
Chop length (cm)	2.9	2.1	0.1	ns
Throughput (kg/h)	861.5	857.0	2.5	ns

The mean chop length of both maize fodder and Napier grass was 2.1 and 2.9 cm, respectively. Forage particle length has a critical influence on feed intake and the functionality of the rumen in dairy cattle (Bhandari et al., 2007; Yang and Beauchemin, 2009). The mean chop length produced by the prototype was within the acceptable range of between 1 to 4 cm required to maintain proper rumination and salivation (Moharrery, 2010).

Mechanization of the forage chopping process is intended to reduce on farm labor demand and drudgery while improving feed intake and feed use efficiency. A diesel engine was selected because unlike petrol engines, diesel engines are

known to be more efficient (Harry and John, 2007). In addition, the cost per liter of diesel (1.04 USD) is lower than that of petrol (1.11 USD) implying that farmers can be able to chop forage at a much lower cost, which in turn contributes to the improved efficiency and profitability of the dairying systems. Also discuss time taken to chop in relation to use of rudimentary tools like the panga.

6.0 Conclusion

The NARO forage chopper prototype is a simple, low-cost and versatile prototype powered by a 7.0 horsepower diesel engine that can be used to chop a variety of forage resources. With chopping throughput of 859.1 kg of forage per hour, the machine uses one liter of diesel to chop 973.2 and 983.6 kilograms of fresh Napier and Maize fodder respectively.

Acknowledgment

This project was supported by the Agricultural Technology and Agribusiness Advisory Services (ATAAS) program through the Competitive Grant Scheme (CGS), funded by the World Bank

References

- 1) Bhandari, S.K., Ominski, K.H., Wittenberg, K.M. and Plaizier, J.C., 2007. Effects of Chop Length of Alfalfa and Corn Silage on Milk Production and Rumen Fermentation of Dairy Cows 2355–2366
- 2) Harry, L.F. and John, B.S., 2007. Introduction to Agricultural Engineering technology: A problem solving approach, Third (Springer Science+Business Media LLC)
- 3) Kiyimba, F.L., 2011. Tools for Women's Empowerment? The case of the forage chopper for smallholder dairy farmers in Uganda (Wageningen University)
- 4) Lukuyu, B., Gachuri, C.K., Lukuyu, M.N., Lusweti, C. and Mwendia, S., 2012. Feeding dairy cattle in East Africa, B. Lukuyu and C. Gachuri K (eds), (East Africa Dairy Development project (EADD): Likoni Lane, off Denis Pritt Road, Nairobi, Kenya)
- 5) Moharrery, A., 2010. Effect of Particle Size of Forage in the Dairy Ration on Feed Intake, Production Parameters and Quantification of Manure Index 23, 483–490
- 6) Yang, W.Z. and Beauchemin, K.A., 2009. Increasing physically effective fiber content of dairy cow diets

through forage proportion versus forage chop length : Chewing and ruminal pH 1603–1615

- 7) Zemelink, G. and Mannelje, L., 2002. Value for animal production (VAP): a new criterion for tropical forage evaluation 96, 31–42