

MITIGATION OF HARMONICS IN ACTIVE NEUTRAL POINT CLAMPED MULTILEVEL INVERTER

MR. BISWA BHUSAN DAS¹, BHENUKA KHARE²

^{1,2}DEPARTMENT OF ELECTRICAL ENGINEERING, CSVTU UNIVERSITY, BHILAI

Abstract:- Multilevel inverter is one of the most recent and popular type of advances in power electronics. It synthesizes desired output voltage waveform from several dc sources used as input for the multilevel inverter.

As one of the most popular hybrid multilevel inverter topologies, the Seven-Level Active-Neutral-Point-Clamped inverter (7L-ANPC) combines the features of the conventional Flying-Capacitor (FC) type and Neutral-Point-Clamped (NPC) type inverter and was commercially used for industrial applications. In order to further decrease the number of active switches, this paper proposes a Seven-Switch 7L-ANPC (7S-7L-ANPC) topology, which employs only seven active switches and two discrete diodes. The analysis has shown a lower current rating can be selected for the seventh switch under high power factor condition, which is verified by simulation results. The modulation strategy for 7S-7L-ANPC inverter is discussed.

Our project presents the fundamental voltage source and current-regulated method. Simulation work is done using the MATLAB software which validates the proposed method and finally THD comparison is presented for analysis.

KEYWORDS: Pulse Width modulation, Multilevel Inverter, Cascaded H-Bridge Inverter, Total Harmonic Distortion, Matlab

1 INTRODUCTION

Multilevel converters are mainly utilized to synthesis a desired single- or three-phase voltage waveform. The desired multi-staircase output voltage is obtained by combining several dc voltage sources. Solar cells, fuel cells, batteries and ultra-capacitors are the most common independent sources used. One important application of multilevel converters is focused on medium and high-power conversion. Nowadays, there exist three commercial topologies of multilevel voltage-source inverters: neutral point clamped (NPC), cascaded H-bridge (CHB), and flying capacitors (FCs).

The five-level inverter is a good choice for industrial application because of lower Total Harmonic Distortion (THD), reduced switching stress and hence lower switching losses compared to the three-level inverter. For the conventional Five-Level Neutral-Point-Clamped (5L-NPC) inverter, as shown in Fig. 1 (a), there are three

clamping points in the DC-link (P, O and Q). The control strategy to keep voltages of each clamping points is complicated. Additionally, reverse recovery currents from clamping diodes will increase the switching losses of the system. Another conventional five-level inverter topology type is Five-Level Flying-Capacitor (5L-FC) inverter. As shown in Fig. 1 (b), the increased number of capacitors leads to increased volume of the system as well as complex control method to balance the voltages of both DC-link capacitors and FCs.

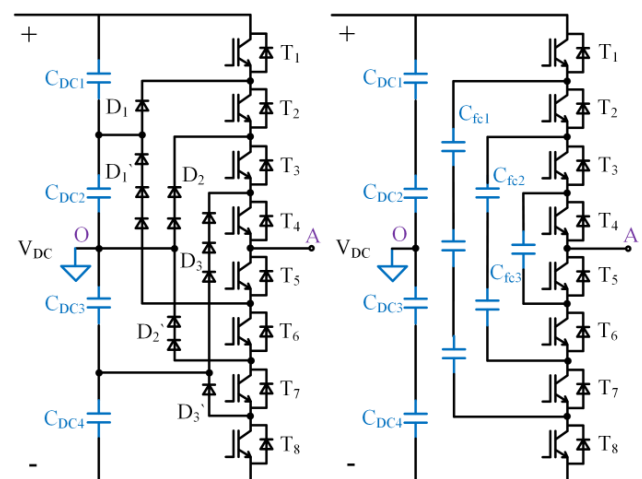

Fig. 1. The conventional five level inverter topologies. (a) 5L-NPC. (b) 5L-FC.

In recent years, hybrid multilevel inverters are receiving more attentions in both academia and industry because they combine the features of many conventional multilevel inverter topologies. As one of the most popular hybrid multilevel inverter topologies, the Five-Level Active-Neutral-Point-Clamped (5L-ANPC) inverter combines the characteristics of NPC type and FC type inverters.

This topology enables the modularity factor that is lacking in the NPC type inverter by adding the FC power cell to reach higher level without adding series-connected diodes.

2 PROBLEM STATEMENT

The typical voltage source inverters gives the output voltage at the poles with levels $+V_{dc}/2$ or $-V_{dc}/2$ which is the DC link voltage also known as two level inverter. To attain a quality output voltage or current waveform with minimal number of ripple content, it needs high

switching frequency along with other discrete pulse width modulation techniques. In high voltage and power application the two level inverters have some constraint in operating at high frequency mainly because of switching losses and restriction of equipment rating.

3 OBJECTIVE

NPC type Multilevel inverters plays vital role in the field of power electronics and being extensively used in various industrial and commercial applications because it possess low electromagnetic interference and the efficiency is considerably high. NPC Multilevel inverters have become more favoured over the years in electric high power application with the affirmation of less disturbances and the contingency to operate at lower switching frequencies than typical two-level inverters.

For the ordinary Five-Level Neutral-Point-Clamped (5L-NPC) inverter, as present in Fig.1), there are three clamping points in the DC-link. The regulation approach to keep voltages of each clamping points is complex. Additionally, inverse improvement currents from clamping diodes will boost the switching losses of the system.

4 SIMULINK MODEL

The simulation model is shown in the figure below. The implementation of 3 phase Neutral Point Clamped Multilevel inverter in MATLAB software is done. In this model MOSFET is used as switching device, opto-isolator is used to give gate pulse to the thyristor. The output voltage is taken between line to line and phase to phase. The total THD counts and the output current and voltage waveform is shown in the figure. A common neutral point is taken outside and grounded.

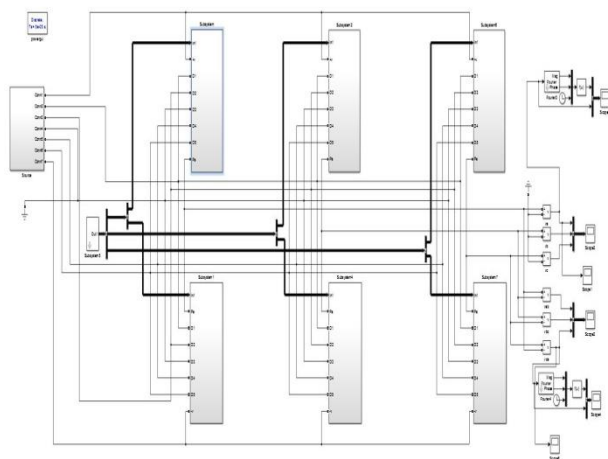

Fig. 2: Block Diagram of Proposed Methodology NPC

In the figure 2 block diagram of proposed method of clamped inverter is presented 6 blocks which is connected with source. Each 6 block has a neutral point. Each pulse generator has 6 sine wave level changer which will be cleared in subsystem model.

NPC multilevel inverter consists of 1 source 6 subsystem models and switch system as illustrated in Figure 2. First, the input DC voltage is described as VDC. The DC-link exists of two series-fetched capacitors (C1, C2) in NPC inverter whose voltages are graded at half of DC voltage (VDC/2). . In case of 3-stage NPC inverter, clamping diode, D1 and D4 clamped the DC bus voltage into three voltage level, +V_{dc}/2, 0 and Diode, D4 equality out the voltage equally distributed between S_{4in} and S_{4out} with S_{4in} blocking the voltage across C₁ and S_{4out} blocking the voltage across C₂.

The 7-level NPC multilevel inverter consists of 1 source 6 subsystem models and switch system as illustrated in Figure 2.

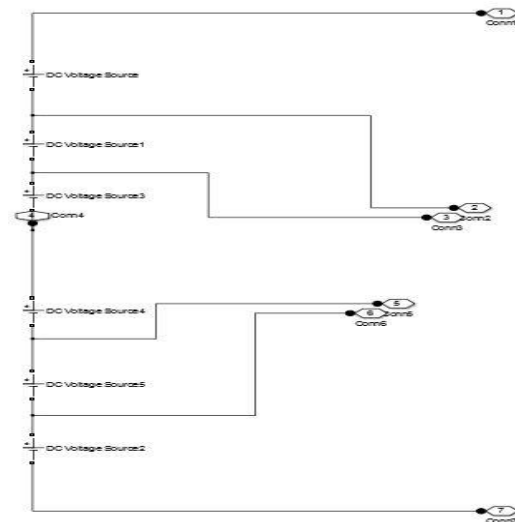

Fig. 3: Subsystem of Source

. The clamping diodes are connected in such a way that it blocks the reverse voltage of the capacitor as shown in fig 3. Two capacitors have been used to divide the DC link voltage into three voltage level i.e. +V_{dc}, 0V and -V_{dc}, thus the name of 3-level. Same as in 7-level it reverse the 7 voltage level.

Here one point is common point and the 6 DC voltage sources are equally distributed both side of neutral point.

In this work, twelve triggering signals are needed for the 7-level NPC inverter. These signals should be synchronized with the AC supply voltage. Since the Matlab/Simulink does not have such triggering block set, a new triggering block has been designed and developed using the block set obtained from Simulink Toolbox. Also, the gate signals sequence and duration of conduction angle of the IGBTs has been determined.

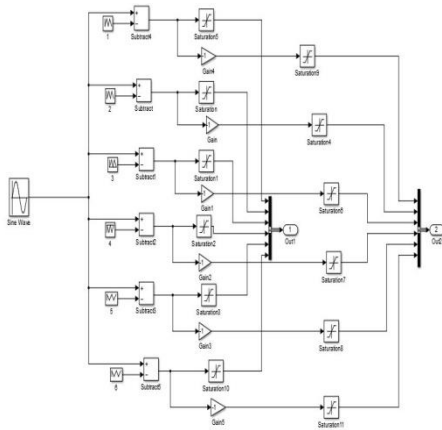

Fig. 4: Subsystem of Pulse Generation of 7 Level NPC Inverter

Here Pulse generator is given the value with phase shift so as to control the neutral clamped inverter to produced desired output level of voltage at the output. The pulse generator block generates square wave pulse at un-varying intervals. The block wave shape parameter amplitude, pulse width, period and phase delay conclude the shape of the output wave shape. If a level changer block is in a resettable subsystem that hits a reset trigger. The block output resets to its initial condition. In our subsystem we are using 6 pulse generators as shown in figure 4.

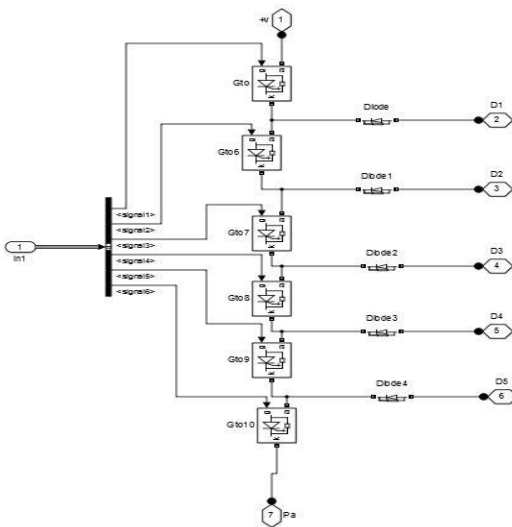

Fig. 5: Subsystem of Switch of 7 Level NPC Inverter

If action subsystem block is a subsystem block preconfigured as a starting point for creating a subsystem whose execution is enabled by an external block than it evaluates a logical expression and depending on its result of evaluation. Here the subsystem of switch is given in figure 5.

5 OPERATING PRINCIPLE

Working is based on convention neutral point clamped converter. NPC inverter has 7 switching states to produce 7 output level +3,+2,+1,0,-1,-2 and -3. When

switches (T1, T2) or (T3, T4) are switched on, the inverter is producing +2 or - 2 output stages. Similarly, for the switching states which produce +1 or -1 levels, (T1, T3) or (T2, T4) are turned on.

In this way +3 and -3 level is also generate. Here input voltage is 100V and the phase voltage is 200V. By the Simulink model after burn the program in MATLAB following result is produced.

The PWM strategy has been used in 7L inverter i.e. apparent switching frequency doubling (ASFD) to active switching to active switching frequency doubling.

The switching state and sequences are analysed at one switching period T_s under four different saturations:

1. $0 < V_{ref} < 0.5$
2. $V_{ref} > 0.5$
3. $-0.5 < V_{ref} < 0$
4. $V_{ref} < -0.5$

T1, T4, T3 are determined by V_{ref} . When T4 off V_{ref} is positive and T1 is off V_{ref} is negative. When T1 on T4 is on, T7 must be Switched off. T5 and T6 switched on and off based on sign of output current. T2 & T3 commute on works switching frequency f_s when the phase voltage occurs at double frequency.

6 RESULT ANALYSIS

A low harmonics content of a proposed 7-level NPC inverter simulation model has been successfully designed and developed. The entire model has been constructed in MATLAB to obtained results from the simulation. The voltage THD values of the proposed inverter are lower than that of the same inverter using different modulation techniques.

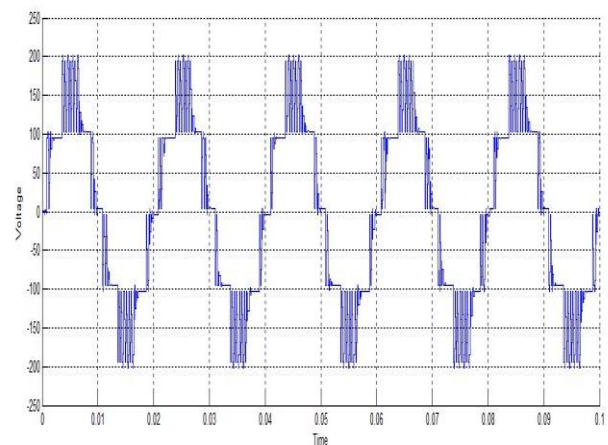

Fig.6: Output of 7 Level NPC Multilevel Inverter

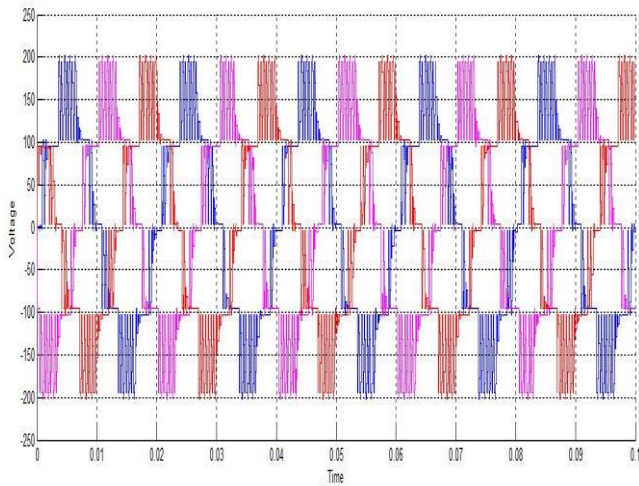

Fig:7: Simulation signal Analysis of 7 Level NPC Inverter

Like 5L-NPC inverter the 7s 7L NPC inverter has switching state to generate the output voltage levels: +2,+1,0,-1,-2.

The voltage i.e line voltage and phase voltage for 7L-7S NPC model is 154.1 v with THD of 12.20% and 266.5v with THD of 8.70%.

In this case the measured peak to peak voltage supply is reduced to 2.4 v with the sinusoidal wave of fundamental voltage 266.5v.the inverter produces good quality of current waveform without distortion.the measured THD value of voltage is 8.70%. the current waveform and voltage waveform is shown in fig .6 and fig 7 The DC link voltage for the system is 100v at the rate of 50 Hz. The modulation index is around 0.8 at unity power factor conduction. The proposed modulation strategy will result in low current which means system cost can be reached further.

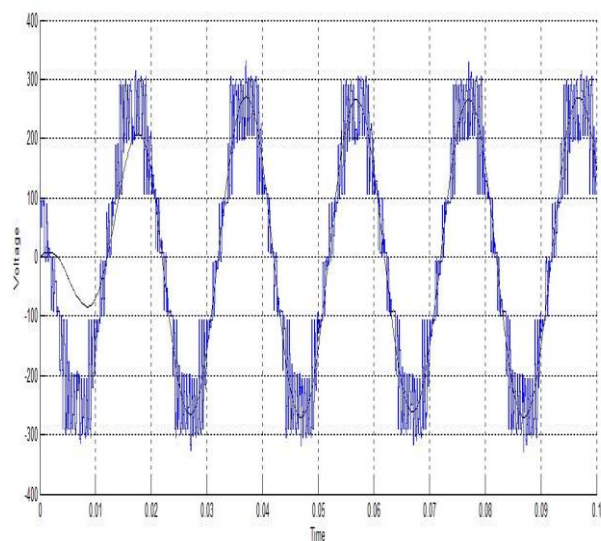

Fig:8: Simulation signal Analysis of 7 Level NPC Inverter

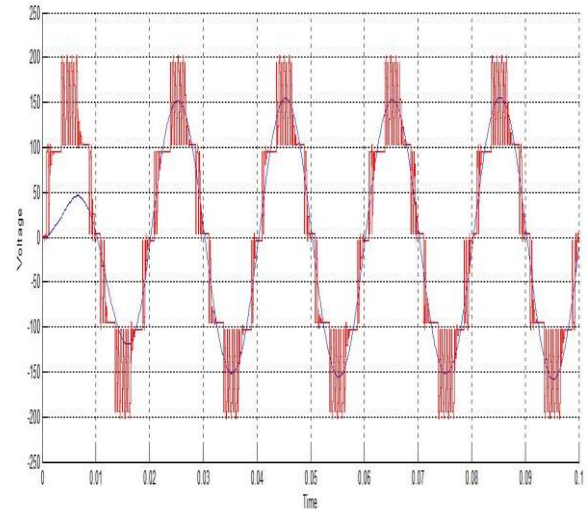

Fig 9 Simulation signal Analysis of 7 Level NPC Inverter

TABLE 1: THD % of 7 levels NPC Multilevel Inverter

THD%	Line voltage	Phase voltage	Line current
	12.20%	8.70%	6.15%

The fundamental frequency are 154.1 Hz and THD% is 12.20% for line voltage, 266.5 Hz for phase voltage and THD% is 8.70%, 264.1 Hz for line current and THD% is 6.15%.

REFERENCES

1. Maheswari, S. Mahendran, Dr. I. Gnanambal (August 2012), "Implementation of Fundamental Frequency Switching Scheme on Multi -Level Cascaded H-Bridge Inverter Fed Three Phase Induction Motor Drive" Wulfenia journal, Klangfurt, Austria, Vol 19, No. 8, pp10-24.
2. FaeteFilho, Leon M. Tolbert, Yue Cao and BurakOzpineci,(september/October 2011) "Real-Time Selective Harmonic Minimization for Multilevel Inverters Connected to Solar Panels Using Artificial Neural Network Angle Generation", IEEE Transactions on industry applications, vol. 47, no. 5, pp2117-2124.
3. Hossein Sepahvand, Jingsheng Liao and Mehdi Ferdowsi,(november 2011) "Investigation on Capacitor Voltage Regulation in Cascaded H-Bridge Multilevel Converters With Fundamental Frequency Switching", IEEE Transactions on industrial electronics, vol. 58, no. 11,pp5102-5111.