

SMART DIGI TRAIN

Aditya Parulekar¹, Abhishek Mahimkar², Harshal Patil³, Sarthak Joshi⁴

¹Student ,Dept of Electrical Engineering, Vishwaniketan iMEET , Maharashtra,India

² Student ,Dept of Electrical Engineering,Vishwaniketan iMEET ,Maharashtra,India

³ Student ,Dept of Electrical Engineering,Vishwaniketan iMEET ,Maharashtra,India

⁴Assistant Professor, Dept of Electrical Engineering,Vishwaniketan iMEET,Maharashtra,India

Abstract - Considering the current state of turmoil in the Indian railways, the controversy surrounding the use or rather the ineffective use of technology in the railways, there is an aggravating need for some improvement in technology and at a low cost. One quick-fix solution to this is the indigenously developed technologically sound and readily available Anti-collision Device". But the drawback of that technology is its high cost of installation. We are developing an "Intelligent train" which can not only avoid collisions, but at the same time it can make train management very easy.

This train is equipped with a controller that enables the automatic running of the train from one station to another. This proposed system is an autonomous train and it eliminates the need of any driver. Thus, any human error is ruled out. In this project microcontroller from 8051 family has been used as CPU. Whenever the train arrives at the station it stops automatically, as sensed by IR. The platforms are detected with the help of IR sensors. Also if number of passengers are zero in train then train leds are switched off.

Key Words: Turn oil , Indian Railways , Intelligent train station , Automation , Acceleration , LCD , Motor Driver

1.INTRODUCTION

For the extensive Railway network in India, an efficient management system is required to avoid train accidents. Although the current safety system is appreciable yet owing to motorman negligence or bad atmospheric conditions can lead to unavoidable accidents.

Our intended system aims at decreasing the margin of error of the system in existence and thereby making it safer. Also we are making it as ecofriendly with a no usage of Fuels and diesels. It is with the help of acceleration mechanism and stator rotation we can generate electric energy for energy provision of coaches lights and Fans. In modern days train transportation has become the most economical and safe way of public transportation system. It helps to connect two major cities and provides a high speed transportation services to the public.

The unmanned metro train (Driverless) allows a highly secure and high performance means of transportation. The prototype makes use of microcontroller to control the train movements. The train runs between two predefined

stations. It also provides a facility of collision avoidance in case of two trains being on the same track. The distance between two stations are also predefined. The train runs between two stations without human intervention. It provides a reset switch to the passenger which acts as an emergency braking system to stop the train in case of emergency. The main idea of the approach is to allow automatic metro train system which is completely unmanned and is precise and errorless in its operation. Counting of passengers happens by using bidirectional detection by IR and photodiode

2. Features

- Dynamo - led concept
- Power saving on platform - led on/off - 50% or 100%
- Accident avoidance - train stop - front side obstacle sensor
- LED or toy FAN as per crowd density
- Overhead wire break
- LCD display
- 8051 controller, DC motor
- Wind turbine single for single compartment
- 2 compartment
- When overhead wire break then will send signal from field to train and train will get stop
- We will use (active) RF comm for overhead wire break feature

3.WORKING

- ❑ Train side one switch is provided to on and off the train.
- ❑ Train side obstacle sensor is used to detect obstacle, whenever obstacle is detects it gives signals to microcontroller about obstacle detection and controller will stop the motors with the help of Motor Driver and buzzer will on.
- ❑ IR sensors are used to check people inside the train. If IR sensors does not sense any human/ motion then train LED's and Fans will be switched off. If IR sensor senses any human/ motion then LED's and Fans will be switched on.
- ❑ If there any overhead wire is break , through active RFID receiver microcontroller will receive a signal to stop the train from active RFID transmitted

which present at platform side and buzzer will also on.

- Platform side consists of two IR sensor to detect Train. Platform side also two IR sensors are used, when train will arrive at station then only 100% LEDs will on or else only 50% LEDs will remain on at station.
- Front side of the train there is LCD will display to display crowd status of the train. Energy generation through Dynamo concept and wind mill is shown using LED glowing.

4. BLOCK DIAGRAM

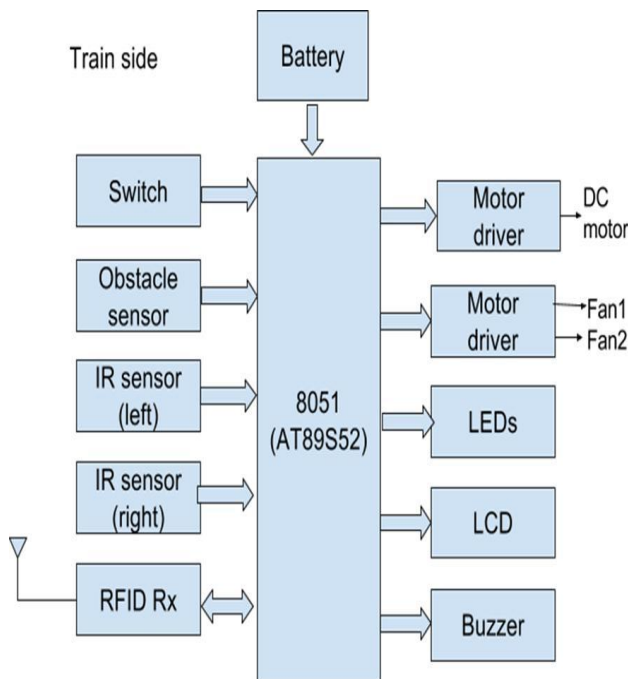

Fig -1: Block Diagram

5. COMPONENT DETAILS

5.1 Microcontroller (AT89S52):

The AT89S52 is a low-power, high-performance CMOS 8-bit microcontroller with 8K bytes of in-system programmable Flash memory. The device is manufactured using Atmel's high-density nonvolatile memory technology and is compatible with the industry-standard 80C51 instruction set and pin out. The on-chip Flash allows the program memory to be reprogrammed in-system or by a conventional nonvolatile memory programmer. By combining a versatile 8-bit CPU with in-system programmable Flash on a monolithic chip, the Atmel AT89S52 is a powerful microcontroller which provides a highly-flexible and cost effective solution to many embedded control applications.

The AT89S52 provides the following standard features: 8K bytes of Flash, 256 bytes of RAM, 32 I/O lines, Watchdog timer, two data pointers, three 16-bit timer/counters, a six-vector two-level interrupt

architecture, a full duplex serial port, on-chip oscillator, and clock circuitry. In addition, the AT89S52 is designed with static logic for operation down to zero frequency and supports two software selectable power saving modes. The Idle Mode stops the CPU while allowing the RAM, timer/counters, serial port, and interrupt system to continue functioning. The Power-down mode saves the RAM contents but freezes the oscillator, disabling all other chip functions until the next interrupt or hardware

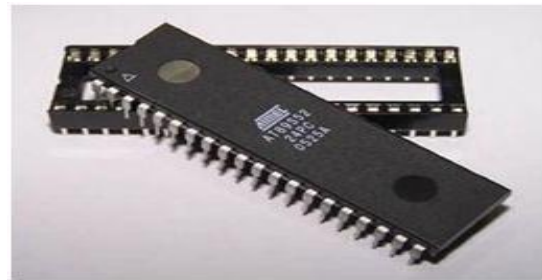

Fig-2: Microcontroller (AT89S52)

5.2 MOTOR DRIVER

Since motors require more current than the microcontroller pin can typically generate, you need some type of a switch (Transistors, MOSFET, Relay etc.,) which can accept a small current, amplify it and generate a larger current, which further drives a motor. This entire process is done by what is known as a motor driver. L293D is a typical Motor driver or Motor.

Driver IC which allows DC motor to drive on either direction. L293D is a 16-pin IC which can control a set of two DC motors simultaneously in any direction. It means that you can control two DC motor with a single L293D IC, Dual H-bridge Motor Driver integrated circuit (IC). The L293D can drive small and quiet big motors as well.



Fig-3 : Motor Driver

5.4 DC Motor

In any electric motor, operation is based on simple electromagnetism. A current-carrying conductor generates a magnetic field; when this is then placed in an external magnetic field, it will experience a force proportional to the current in the conductor, and to the strength of the external magnetic field. The internal configuration of a DC motor is

designed to harness the magnetic interaction between a current-carrying conductor and an external magnetic field to generate rotational motion.



Fig-4:DC Motor

5.5 LED (LIGHT EMITTING DIODE)

LEDs offer benefits such as small size, long lamp life, low heat output, energy savings and durability. They also allow extraordinary design flexibility in color changing, dimming and distribution by combining these small units into desired shapes, colors, sizes and lumen packages. LEDs are solid state semiconductor devices. LED illumination is achieved when a semiconductor crystal is excited so that it directly produces visible light in a desired wavelength range (color). LED units are small, typically 5mm.



Fig-5:LED's

6. HARDWARE REQUIREMENT:

- AT89S52- Train side
- AT89C2051 - Platform side
- Obstacle sensor
- LEDs
- IR sensors x 4
- Buzzer
- Switch
- Motor drivers x 2
- DC motor x 3
- Active RFID Tx and Rx
- Power supply

7. SOFTWARE REQUIREMENT

- Keiluvision- 8051 programming
- UC flash- burn program into 8051 IC
- Diptrace - PCB layout

8.ADVANTAGES

- Modeling of existing railway techniques and implementing their improvements.
- All features can be projected in a small area (toy train).
- Study equipment designed to meet working conditions of railway operations.
- Compact apparatus with high degree of operational reliability. Immune to climatic conditions most of the times.

9. APPLICATIONS

- Local train for energy saving and local train security
- Bus
- Private Vehicles

10. FUTURE SCOPE :

- On-panel signal system can be implemented using Zigbee technology.
- Anti-Collision Device can be implemented using Global Positioning System (GPS).

11. CONCLUSION:

Nowadays the accidents of trains are increasing day by day. Of these major accidents are occurring due to human faults. A man can do a mistake but a programmed processor doesn't have a chance of doing error. This is the main reason behind this project. This is a highly advanced technology which is currently used in developed nations such as Japan, Germany, France etc. By using this auto metro train the timings of the train will be exact and it avoids a lot of inconvenience to the passengers. This project will greatly reduce the human intervention in the control of trains and hence saves a lot of time and money. Also there is no system to control energy waste due to unwanted fans and lights are "ON" on platform and as well as in train .We can control through micro controller.

12. REFERNCES:

- [1]Railway Safety Statistics, http://ec.europa.eu/eurostat/statistics-explained/index.php/Railway_safety_statistics
- [2] Indian National Crime Records Bureau, www.ncrb.gov.in
- [3]About Indian Railways, http://indianrailways.gov.in/railwayboard/view_section.jsp?lang=0&id=0,1
- [4] Sambamurthy, N., Ahammad, H. "Prevention of train accidents Using Wireless Sensor Networks", Int. Journal of Engineering Research and Applications, ISSN : 2248-9622, Vol. 3, Issue 6, Nov-Dec 2013, pp.1592-1597

[5] Geethanjali, M., Shamanthan, L.D.V.S., Krishnan, K.P.S., Raji, G. "RF Based Train Collision Avoidance System", Annual IEEE India Conference (INDICON), 13-15 December 2013

[6] Oh, S., Yoon, Y., Kim, Y. "Automatic Train Protection Simulation for Radio-based Train

Control System", International Conference on Information Science and Applications (ICISA), 23-25 May, 2012.

[7] Chellaswamy, C., Arul, S., Balaji, L. "Design and Analysis of an Intelligent Collision Avoidance System for Locomotives", International Conference on Sustainable Energy and Intelligent Systems (SEISCON), 20-22 July, 2011

[8] Zhang, X., Lakafosis, V., Traille, A., Tentzeris, M. "Performance Analysis of Fast Moving RFID Tags in State-of-the-art High-speed Railway Systems", IEEE International Conference on RFID-Technology and Applications (RFID-TA), 17-19 June, 2010.

[9] Garcia, C.R., Lehner, A., Strang, T., Rockl, M. "Comparison of Collision Avoidance Systems and Applicability to Rail Transport", 7th International Conference on ITS (ITST'07), 6-8 June, 2007.

[10] Clicker 2 for PIC18F] user Guide, www.mikroe.com