

# ELECTRICITY THEFT MONITORING AND ITS CONSUMPTION SAVINGS

Ms.V.Sellam<sup>1</sup>, Saurav Chowdhury<sup>2</sup>, MVS Vashishta<sup>3</sup>, Anirudh Singh<sup>4</sup>

<sup>1</sup>Asst. Prof, SRMIST, Chennai

<sup>2,3,4</sup>Student, SRMIST, Chennai

\*\*\*

**ABSTRACT-** Automation in public sectors of the required services is the updated trend of the present era. Government prefer not only to give quality service but also the corrupt and error free services to its citizens. So to enhance this idea the project is proposed which is an advanced system which helps electricity corporations and electricity boards to switch towards advanced movement of "ANTI POWER THEFT". This project helps in order to give quality service to its customers without any kind of problem, along with an aim of reducing recurring theft of energy to a considerable extent. Automation of power supply system is also a need because in the busy timetable of people many a times unintentionally the wastage of power is done.

## INTRODUCTION

Theft of electricity is a criminal practice by stealing electric power. It is considered as a crime and liable for punishment by heavy fines and in some cases jail. The basic method of stealing electricity is direct hooking from line- Hooking(catching) is the most used method. 80% of global power theft is by direct tapping from the line. The consumer taps into a power line from a point ahead of the energy meter[4][5]. This energy consumption is unmeasured and obtained with or without switches. There are various other methods which are described in problem statement section. The wastage of power supply is also a common problem. There is a solution to control energy efficient lights at home by using automatic room light controller.

## PROBLEM STATEMENT

The various other methods of electrical power theft are:

1. **Bypassing the energy meter-** In this method the input terminal and output terminal of energy meter is short circuited preventing the energy from registration in energy meter.
2. **Injecting foreign element into the energy meter-** Meters are manipulated via remote by installing a circuit inside the meter so that the meter can be slowed down anytime. This kind of modification can avoid external inspection attempts because the meter is always correct unless the remote is turned on.
3. **Physical obstruction-** This type of interfering is done to electromechanical meters with the rotating element. Foreign material is placed inside the meter to obstruct the free moment of the disc. Lower rotating disk signals less energy consumption.
4. **ESD attack on electronic meter-** This type of interfering is done on electronic meter to make either temporary damage or permanent damage.
5. **Reversing the dials of meter-** This is the commonly used method in which the meter is open itself without damaging its seal and reversing the dial which might be complicated and required expert skills

## EXISTING SYSTEM

In the current electricity supply system in India electrical meter used magnetic devices in voltage and current measurement circuit and are susceptible external magnetic fields. When placed next to a meter a powerful magnet can saturate the sensor magnetic Core and introduce large error in measurement or even disable them completely by interfering with its power supply transformer.

We are still using manual system to control lighting system in our houses which sometimes leads to wastage of power supply as we are not switching off the power when we are leaving the particular area.

## LITERATURE SURVEY

1. **Electricity theft detection using smart meter data--** In this idea [1] smart meters was being used to monitor the theft. A temperature dependent predictive model which uses smart meter data and data from distribution transformer to detect electricity theft in the area. The drawback of the system was that the theft was monitored for the whole area rather than the individual. The main problem is with the theft of power supply is with the individual but here the monitoring is done for the whole area.

2. **A novel design to prevent electricity theft from pole mounted distribution boxes-** In India distribution losses are substantial from pilferage of distribution line and connected equipments like energy meters distribution boxes and various connectors. Various State Electricity Board have started using aerial bunched cables for prevention against theft by direct hooking on conductors but it has been observed that maximum power theft occurs through distribution box most vulnerable component against power theft. The proposed scheme was theft proof distribution box will be made with reduced ohmic loss. The major problem of this idea is its construction and implementation[2].
3. **Integrating Zigbee light control into existing building automation--**The architecture of the system[3] consist of BAS a Modbus/ TCP backbone and zigbee wireless sensor network. This architecture is based on three level functional hierarchy of building automation and control systems. Since it includes 3 level functional hierarchy the construction of the circuit is very much complex and out of the scope of common people.

## PROPOSED SYSTEM

Electricity Board will transmit the energy via RF transmitter. At the user end the RF receiver receive the transmitted power from the electricity board and then provides acknowledgement about the reception of power by activating a micro switch. The acknowledgement information will be transmitted to the head office via RF transmitter. This is the basic way of operation employed in the proposed methodology. While coming to the part of theft identification there are two stages of -

1. Alarm beep with message alert
2. Fine imposed with message intimation

Automatic operation of room lights and appliance control

The system is designed by using two sets of IR transmitter and the IR sensors are placed in such a way that they detect a person entering and leaving the room to turn the home appliances. In this minimum Energy Management System a microcontroller is a central Processing Unit which is of 89S51 controller from the 8051 family.

## IMPLEMENTATION

1. The electricity board will transfer the energy with the help of RF transmitter which has to be received at the user end by using RF receiver. If there is any unwanted actions implied on the receiver side the acknowledgement of receiving power will not be reverted back to the RF transmitter. If this situation occurs for the first time a beeping alarm of pilferage of power supply is made with an alerting message send to the destination through the involvement of GSM services intimating about theft with the specified message ELECTRICITY THEFT. If the lapse of acknowledgement again takes place from being reverted back to RF transmitter by surpassing the permissible first alert a fine of prefix amount is imposed on the user and supply to the user is disconnected automatically from the electricity supply board with a specified message sent via GSM as ELECTRICITY THEFT IS BEING CONTINUED AND A FINE HAS BEEN IMPOSED LEADING TO DISCONNECTION OF POWER SUPPLY

2. When a person enters into the room an IR beam is obstructed between the IR transmitter and receiver. The IR obstruction from the sensor I give the corresponding signal to microcontroller. The microcontroller is programmed in such a way that by receiving the signal from sensor it turns on the fans and lights inside the room. When the person leaves from the room another set of IR sensors enable and give control signals to microcontroller to switch off the lights and fans.

## HARDWARE SPECIFICATIONS

### RF Modules (RF Transmitter and receiver)

The RF module operates at radio frequency. The corresponding frequency range varies between 30 kHz & 300 GHz. Transmission through RF is better than IR (infrared) because of many reasons. Firstly, signals through RF can travel through larger distances making it suitable for long range applications. Also, while IR mostly operates in line-of-sight mode, RF signals can travel even when there is an obstruction between transmitter & receiver. Next, RF transmission is more strong and reliable than IR transmission. RF communication uses a specific frequency unlike IR signals which are affected by other IR emitting sources. The RF module is often used along with a pair of encoder/decoder. The encoder is used for encoding parallel data for transmission feed while reception is decoded by a decoder. HT12E-HT12D, HT640-HT648, etc. are some commonly used encoder/decoder pair ICs.

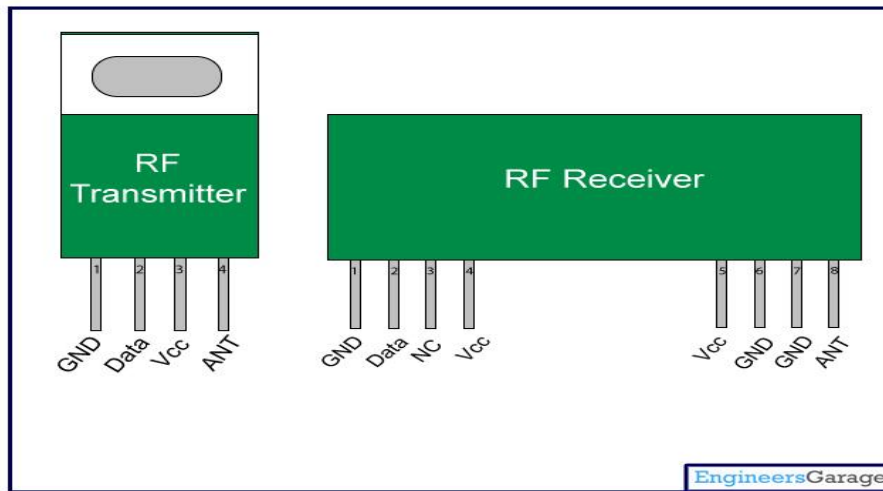

RF Module(Transmitter and Receiver)

### IR SENSORS AND MICROCONTROLLERS

An infrared sensor is an electronic device, that emits in order to sense some aspects of the surroundings. An IR sensor can measure the heat of an object as well as detects the motion. These types of sensors measures only infrared radiation, rather than emitting it that is called as a passive IR sensor.

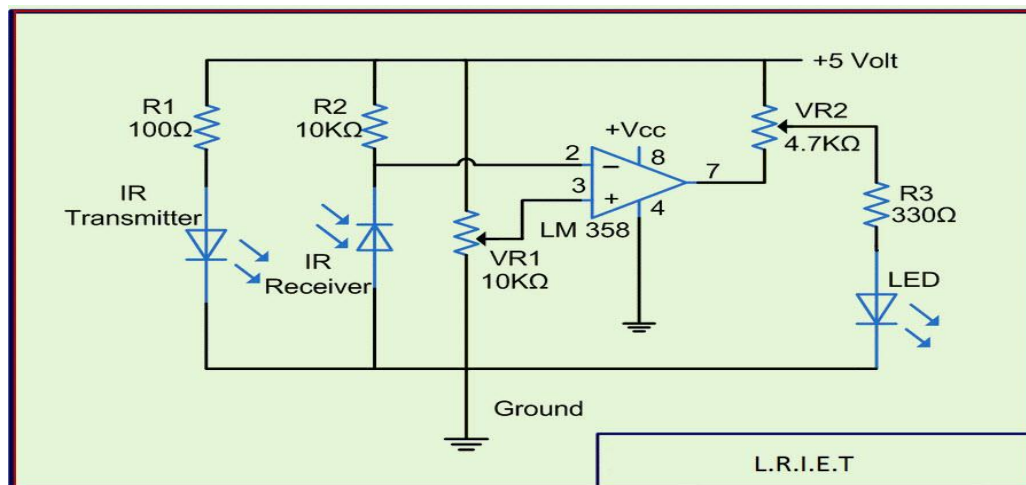

A microcontroller is a small computer on a single integrated chip. A typical microcontroller includes processor, memory, input /output modules. It is programmed in such a way that it may read the instructions from the PIR sensors and implement accordingly.

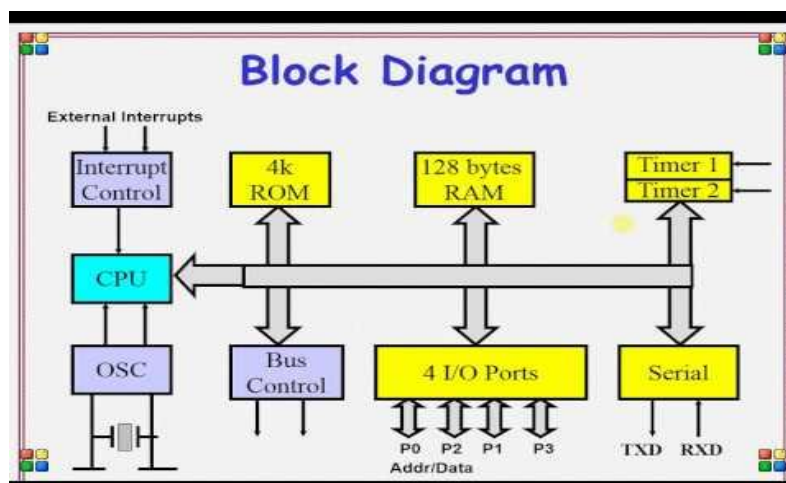

SYSTEM ARCHITECTURE

POWER THEFT MONITORING

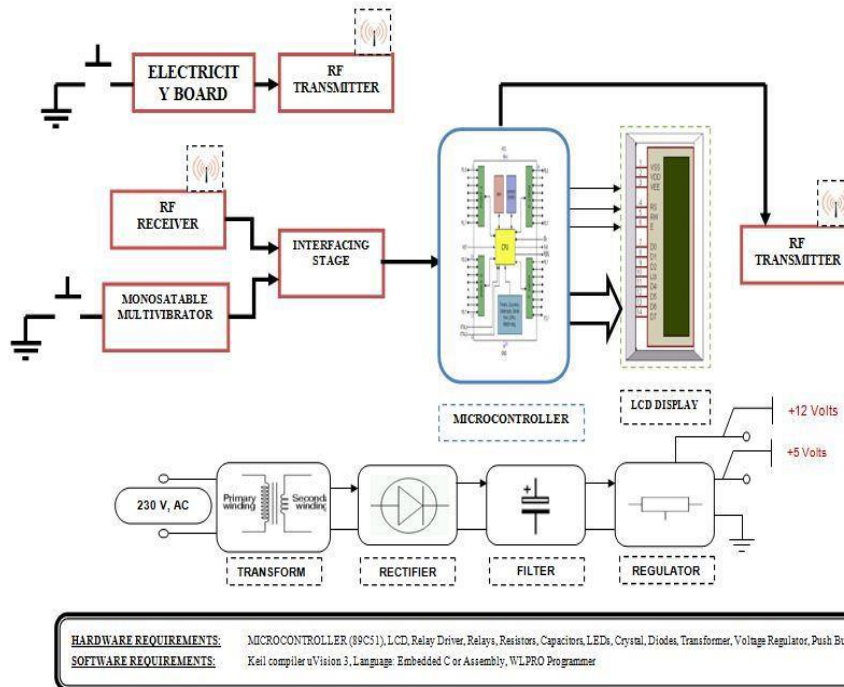

2. AUTOMATION IN LIGHTING

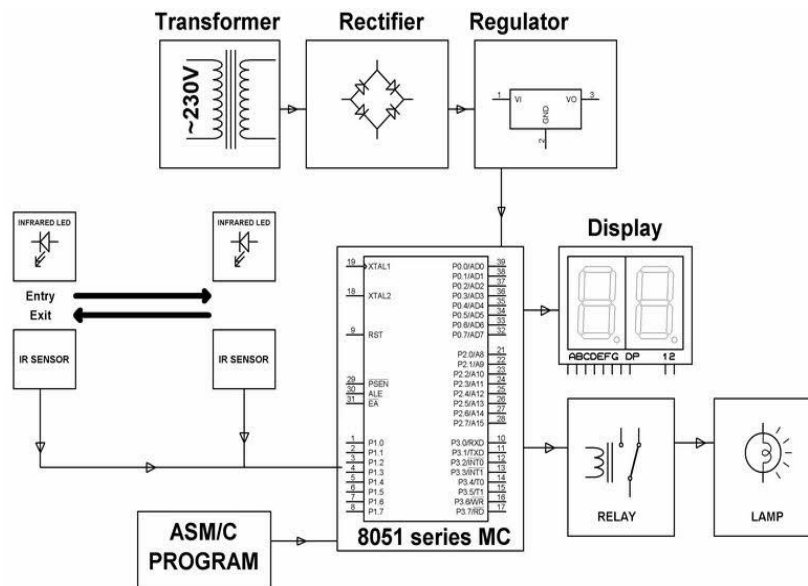

CONCLUSION

Electricity theft leads to various losses involving: tampering of electric meters to misguide bill-information or direct-connections to power-lines. It's impossible to read the commercial-losses by employing good-old power-system analysis-techniques because of the weak information of commercial and the genuine loads in the market-system, which is insufficient-for any valuable calculations of persisting losses. So the check for the check of power theft is very important. Secondly, the wastage of power is also a serious concern in the present era , so an immediate and necessary steps has to be taken to minimize the wastage.

## REFERENCES

- [1] Sanujeet Sahoo, Daniel Nikovski, Toru Muso , “Electricity Theft Detection Using Smart Meter Data”
  
- [2] Ram Krishna Mishra , Krunal Patel, “A Novel Design to Prevent Electricity Theft from Pole Mounted Distribution Boxes”
  
- [3] R. S. Hsiao, D. B. Lin, H. P. Lin, C. H. Chung and S. C. Cheng , “Integrating Zigbee Lighting Control Into Existing Building Automation Systems”
  
- [4] Wikipedia source: [https://en.wikipedia.org/wiki/Theft\\_of\\_electricity](https://en.wikipedia.org/wiki/Theft_of_electricity)
  
- [5] M. Venables, “Smart Meters Make Smart Consumers”