

STATIC AND THERMAL ANALYSIS OF PISTON WITH DIFFERENT THERMAL COATINGS

SYED ARIF ALI¹, NALLA SURESH², ELUMAGANDLA SURENDAR³

¹Student, M. Tech(CAD/CAM), Warangal Institute of Technology & Science, Warangal, Telangana State, INDIA.

²Associate Professor & HOD, Dept. of Mechanical Engineering, Warangal Institute of Technology & Science, Warangal, Telangana State, INDIA.

³Assistant Professor, Dept. of Mechanical Engineering, Warangal Institute of Technology & Science, Warangal, Telangana State, INDIA.

Abstract - Increasing the efficiency of an internal combustion engine is very important in the present market by improving the combustion rate and 100% utilization of heat energy produced in the engine. It is very essential for us to utilize the conventional fuels very economically and reducing the portion of unburned carbon simultaneously to reduce the emissions to avoid pollution. The engine life and performance is mainly depends on the design and the materials used for their manufacturing. Piston plays a vital role in improving the performance of an engine. The use of advance coating materials in the automobile industry giving significant results in improving engine performance.

In this present work a piston is designed using CATIA V5R20 software. Complete design is imported to ANSYS 14.5 software then analysis is performed. Thermal analysis of piston has been done by selecting Aluminum alloy and Titanium Alloy as piston material by applying 1mm coating with different coating materials such as Ni-Cr-Al and Mg-ZrO₃. An analysis of thermal stress and damages due to application of pressure is presented and analyzed in this work. The maximum and minimum heat flux distribution with different combination of piston and its coating materials was observed. Results are shown graphically and a comparison is made to find the most suited design.

Key Words: Heat flux, stress, pressure, engine, heat transfer, temperature field of piston, coatings

1. INTRODUCTION

The demand for energy is increasing day by day. The world is depending mostly on fossil fuels (conventional) to face this energy demands. The

increase in standard of living demands better mode of transport, hence a large number of automobile companies has been come forwarded.. The principal pollutants emitted by the automobile engines after combustion are CO, NO_x, HC and particulates. The modern day automobiles is a result of several technological improvements that have happened over the years and would continue to do so to meet the performance demands of Exhaust-Gas Emissions, Fuel Consumption, Power Output, Convenience and Safety. In order to reduce emissions and increasing engine performance, modern car engines carefully designed to control the amount of fuel they burn. An effective way for reducing automotive emission and increase engine's performance is accomplished by coating automobile piston head with low thermal conductivity materials such as Ni-Cr-Al, Mg-ZrO₃ and ceramic etc.

1.1 Piston Terminology:

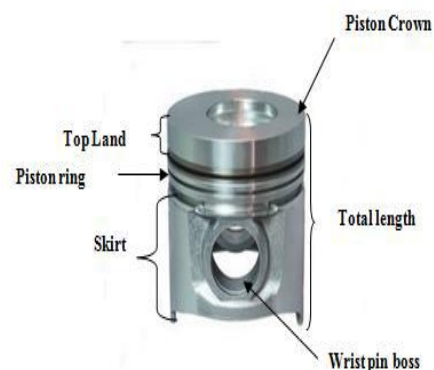

a) Crown: It is top surface of piston which is subjected to tremendous force and heat during normal engine operation.

b) Piston ring: It is part on piston having ring shape which seals the gap between piston and cylinder wall.

c) Skirt: It is portion of piston closest to crankshaft that helps align the piston as it move in cylinder block.

d) Wrist pin boss: It is bore that connects the small end of connecting rod to piston by a wrist pin.

e) Total length of piston: Total length of piston is the length from piston crown to bottom of piston. It is sum of Top land length, length of Ring section and skirt length.

f) Ring land: It is reliefs cut into the side profile of piston where piston ring sit

g) Ring Groove: An area located around the perimeter of the piston that is used to retain the piston ring.

h) Top land: The portion from piston crown to top ring land is called top land.

Functions:

a. To reciprocate in the cylinder as a gas tight plug causing suction, compression, expansion and exhaust strokes.

b. To receive the thrust generated by the explosion of the gas in the cylinder and transmit it to the connecting rod.

c. To form a guide and bearing to the small end of the connecting rod and to take the side thrust due to obliquity of the rod.

1.2 Piston Design

The pressure applied on piston head, temperatures of various areas of the piston, heat flow, stresses, strains, length, diameter of piston and hole, thicknesses, etc., parameters are taken into considerations.

Design Considerations for a Piston:

In designing a piston for an engine, the following points should be taken into consideration:

- It should have enormous strength to withstand the high pressure.
- It should have minimum weight to withstand the inertia forces.
- It should form effective oil sealing in the cylinder.
- It should provide sufficient bearing area to prevent undue wear.

- It should have high speed reciprocation without noise.
- It should be of sufficient rigid construction to withstand thermal and mechanical distortions.
- It should have sufficient support for the piston pin.

Softwares Used : In this project I will be using the two basic design software's, they are AutoCAD, CATIA , for designing. CATIA - abbreviation is Computer Aided Three-

dimensional Interactive Application. Version 5 and revision 20 is used for designing of shock absorber which consists of the following modules as shown in following figure.



Introduction To Ansys .

ANSYS is the standard FEA tool within the Mechanical Engineering Department and also used in Civil and Electrical Engineering. ANSYS provides a cost-effective way to explore the performance of products or processes in a virtual environment. This type of product development is termed virtual prototyping. With virtual prototyping techniques, users can iterate various scenarios to optimize the product long before the manufacturing is started. This enables a reduction in the level of risk, and in the cost of ineffective designs.

Steps In Finite Element Analysis:

- Descritization ,Formulation of properties to each element and concern nodes.
- Assemble all elements for structure Give input such as load , forces ,temperatures etc based

on type of analysis means structural, thermal etc.

- Solve simultaneous line algebraic equations.
- Display the results in the form of graphs.
- The finite element method is a numerical analysis technique for obtaining approximate solutions to a wide range of engineering problems.

2. LITERATURE REVIEW

S Pal, A Deore, A Choudhary etc all.[1], has focused and make easier to choose best coating materials for engine coating purposes and for best operating properties during its service period. The best powder among yttria, alumina and zirconia to be used as a piston coating material i.e., the one resulting in lowest heat flux and low side skirt and bottom temperature has been chosen for the coating purpose. This work then analyses the coated sample for its surface properties such as hardness, roughness, corrosion resistance and micro structural study.

Valentin Mereuta [2], This project explains about the static and thermal stress distribution of the combustion engine piston using cad software. Using SolidWorks the static and thermal analyses are investigated for two variants of a diesel piston, made of different type of materials such as Aluminum 6061 Alloy and Gray Cast Iron material.

Dr.I.Satyanarayana, N. Rajyalaxmi [3], The main goal of this project is to determine both temperature and thermal stress distributions in ceramic coating on an steel alloy piston crown to improve the Thermal efficiency of a diesel engine. Effects of the coating thickness on temperature and thermal stress distributions are investigated, including comparisons with results from an uncoated piston by means of both static and thermal analysis. Two different materials such as silicon dioxide and zirconium was used with a coating thickness of 0.4mm. Temperature at the coated surface is significantly higher than that of the uncoated piston. It is observed that the coating surface temperature increases with coating thickness by decreasing rate. By adding 0.4mm thickness of coating, we have to improve the

thermal efficiency of the coated piston compared to uncoated piston.

K.S.Mahajan and S.H.Deshmukh[4], The main objective of this work is to concentrate on the structural analysis of ceramic coated piston, working under thermal and mechanical loads. Thermal analysis was carried out on uncoated and ceramic coated piston to verify the temperature changes at the ceramic coated regions using Hypermesh and Ansys. The study of thermal stresses generated due to temperature differences at different materials junctions used in coating was analyzed. The stresses due to the mechanical loads were studied to finally determine the structural behavior of the partially ceramic coated pistons.

Mallavarapu Nageswari , Vijaya Kumar[5], was examined in this study on a piston made of aluminum silicon alloy, zirconium and aluminum MgSi materials, and the static and thermal analysis was carried to know thermal behavior of piston to reduce the stress distribution. The analysis is performed on piston by using a CAE tool namely ANSYS. The main purpose is to find the real behavior during combustion process i.e.; static structural and thermal stresses are found.

Balbheem Kamanna, Prof. Bibin Jose etc.all [6],. In this project work an attempt is made to redesign piston crown using TBC on piston surface and to study its Performance. A 150 cc engine is considered and TBC material with different thickness is coated on the piston. 3D modeling of the piston geometry is done 3D designing software Solidworks2015. Finite Element analysis is used to calculate temperature and heat flux distribution on piston crown. The result shows TBC as a coating on piston crown surface reduces the heat transfer rate within the piston and that will results in increase of engine efficiency. Results also show that temperature and heat flux decreases with increase in coating thickness of YSZ.

Jatender Datta ,Dr. Sahib Sartaj Singh [7], This paper illustrates the procedure for analytical design of cast iron , cast alloy steel and carbon graphite pistons using specifications of four stroke 100cc hero bike engine. The results predict the

minimum and maximum value of GRADN: Resultant Temp Gradient on all of these pistons using FEA with applied the temperature 100°C on the top of piston. The 3D modelling of piston is done in Solid works (Feature module) and Simulation module was used to mesh the pistons, thermal analysis with temperature applied on the top of piston head.

Mr. Bhavin D. Patel, Prof. Ramesh N. Mevada, Prof. Dhaval P. Patel [8], reviewed many papers to improve the efficiency of an I.C. Engine and it is reflected different methodology such as thermal barrier coating, HVOF (High velocity oxygen fuel) coating, Particle image velocimetry (PIV), Coating thickness and roughness effect etc. And such system they had applying such kind of coating process those are metal sheet, gas turbine, parabolic reflector, automobile industry etc. Some research paper indicated about optimization method applied coating structure and FEA analysis or CFD analysis. In CI and SI engine, they were done component level coating as per design requirement for surface roughness and life of component. There was not work done on energy saving during power stroke and there is not any provision for inside coating method from above research paper survey.

Mangal Mai Shukla, Om Prakash Tiwari [9], Piston is considered to be one of the important parts of an internal combustion engine. It is a part which bears the pressure of the combustion of the gas inside the cylinder. Normally they are made up of cast iron which bears the gas pressure. It is used to deliver the power via connecting the rod to the main shaft of the engine. Piston made up of gray cast iron coated with a ceramic material (MgZrO₃) which is bonded by special material (NiCrAl) is designed for Mercedes Benz/1985 by machine design approach to determine the dimensions of the piston and then it is modeled in ANSYS Workbench 17.1. The pressure of the 5 N/mm² is applied on the piston. The equivalent stresses are found to be same for both coated and non-coated piston. Thermal analysis of both coated and the non-coated piston is done. The properties like equivalent stresses, temperature variation, and total deformation under pressure and thermal load are determined with the change in the

thickness of the ceramic coating material. It is concluded that ceramic coated piston is able to handle the thermal load and is indifferent towards the structural load.

Dipayan Sinha, Susenjit Sarkar and Samar Chandra Mandal [10], In the present work a piston has been analyzed numerically with a FEA software named ANSYS Workbench to evaluate its thermo mechanical capability under a predefined thermal and structural load. To enhance the performance of the engine, weight of the piston has been kept minimum by optimizing different dimensions. In this process of optimization the stress has also been kept under a certain limit and this process of optimization has been done in a software named Solid Works. To improve the thermal performance of the piston different Thermal Barrier Coatings (TBC) have been imposed and their thermo mechanical performance have been evaluated through couple-field analysis in ANSYS.

Manish Kumar [11], In the present work, the thermal boundary conditions are obtained to calculate the temperature distribution and thermal stress in piston. The analysis is carried out to identify the maximum and minimum stress location in piston. The modeling of piston is carried out in CATIA software whereas ANSYS workbench is used for the Finite Element Analysis. Von Mises stresses criterion is used in Finite element analysis.

Thirakavinod Kumar, B. Ravisekhar [12], In this paper we study, thermal and static structural analyses area unit investigated on a conventional diesel piston, manufactured from aluminum silicon alloy. Secondly, thermal and Static analysis area unit performed on piston, alloy of aluminum with Zirconium material by means that of employing an industrial code, namely ANSYS. The consequences of Zirconium material on the thermal behaviors of the pistons area unit investigated.

M.X. Calbureanu, R. Malciu, D. Tutunea, A. Ionescu and M. Lungu [13], The main purpose of the preliminary analyses presented in the paper was to compare the behavior of the combustion

engine piston made of aluminum alloys. The paper describes the mesh optimization with using finite element analysis technique to predict the higher stress and critical region on the component. As initial condition we considered a temperature on the head piston of 330°C and a total pressure of 5 MPa. There were studied two cases, a piston head and a piston, pin and connecting rod.

Hojjat Ashouri [14], This paper presents finite element analysis (FEA) of a coated and uncoated cylinder heads of a diesel engine to examine the distribution of temperature and stress. A thermal barrier coating system was applied on the combustion chamber of the cylinder heads, consists of two-layer systems: a ceramic top coat (TC), made of yttria stabilized zirconia (YSZ), ZrO₂-8%Y₂O₃ and also a metallic bond coat (BC), made of Ni- Cr-Al-Y. The coating system in this research comprises 300 μm zirconium oxide TC and 150 μm BC. The three-dimensional model of the cylinder heads was simulated in abaqus software and a two-layer viscoplasticity model was utilized to investigate the elastic, plastic and viscous behavior of the cylinder heads.

Vishal Kumar Shrivastava, Prof. Alok Agrawal [15], In this work, firstly, thermal analysis is investigated on a conventional (uncoated) diesel piston, made of aluminum silicon alloy of different material property for design and thermal analysis with boundary condition. This study compared the different aluminum silicon alloy material property and defined the balance composition of piston material for minimums the thermal stress The effects of different property of piston material on the thermal behaviors of the pistons are investigated. The finite element analysis is performed by using computer aided design software. The main objective is to investigate and analysis the thermal stress distribution of piston at the real diesel engine condition during combustion process.

3. DESIGN AND ANALYSIS :

We have been supplied with the .igs file of the Piston ; I have designed the piston according to the dimensions supplied to me in CATIA V5.

The following figures show the development of the design in the CATIA.

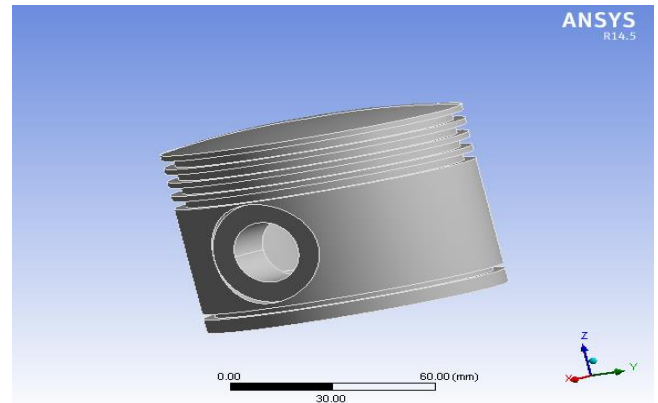

Fig 3.1 : model in CATIA V5

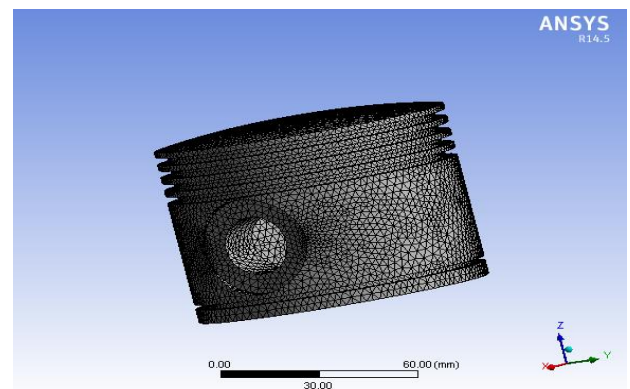

Fig 3.2 : Mesh model in CATIA V5

In this present work i selected ,Al- Alloy and Ti- Alloy materials are used as piston materials and Ni-Cr-Al and Mg-Zr-O₃ materials as coating materials.

Table 3.1 : Materials used for piston and their properties :

Material	Al- Alloy	Ti- Alloy
Density (kg/mm ³)	2.77 e ⁻⁶	4.62 e ⁻⁶
Co-efficient of Thermal Expansion (°c @ 1 ⁰)	2.3 e ⁻⁵	9.4 e ⁻⁶
Thermal Conductivity (w/mm°c)	0.144	2.19 e ⁻²
Youngs Modulus (Mpa)	71000	96000
Poisson:s Ratio (μ)	0.33	0.36
Specific Heat (Mj/ kg °c)	8.75 e ⁺⁵	

Table 3.2 : Materials used for coating and their properties :

Material	Ni-Cr-Al	Mg-Zr-O ₃
Density (kg/mm ³)	7.87 e-6	7.87e-6
Co-efficient of Thermal Expansion (°c @ 1 ⁰)	1.2 e-5	8
Thermal Conductivity (w/mm°c)	1.6e-2	2 e-4
Youngs Modulus (Mpa)	90000	46000
Poisson's Ratio (μ)	0.27	0.2
Specific Heat (Mj/ kg °c)	7.64 e+5	6.5 e+5

At the initial stage the temperature applied to the piston crown is 2000 °c. and the convection heat transfer distribution was observed as fallows.

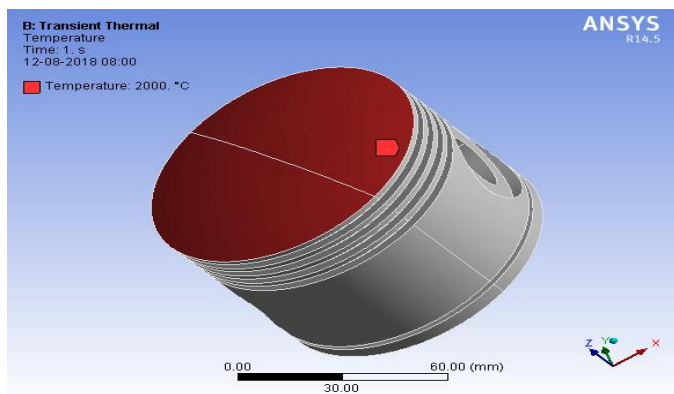

Fig 3.3 : Temperature applied to the Piston top surface

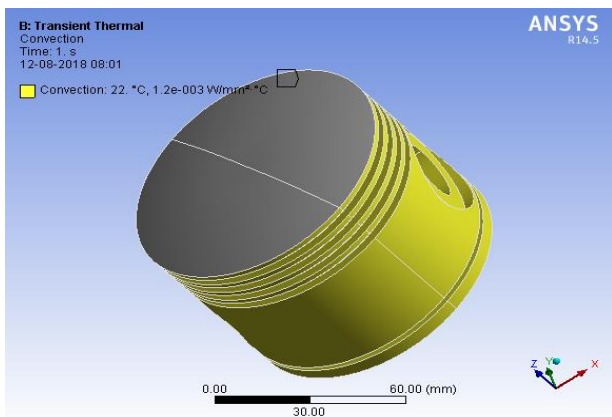

Fig3.4 : Convection applied to the piston surfaces

3.1 OBSERVATIONS :

3.1.1: The Temperature and Heat flux Distribution of piston **without Thermal coating materials** for one second has been observed. also the temperature and heat flux distributions by time (1s) is shown graphically.

Case 1 : A) Temperature Distribution when piston material as Al- Alloy:

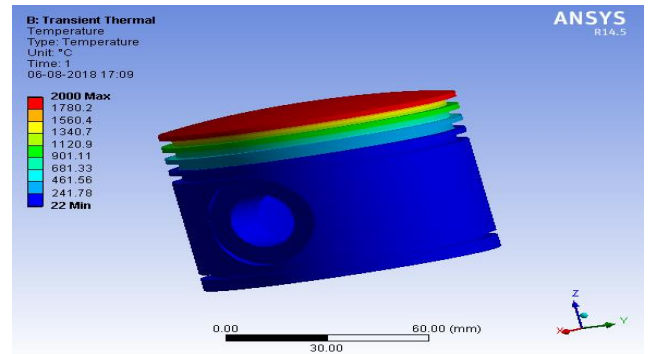
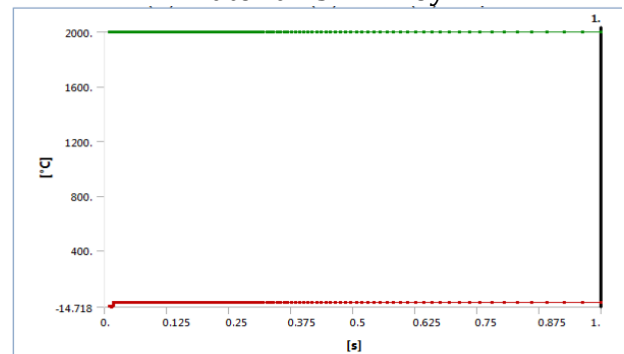
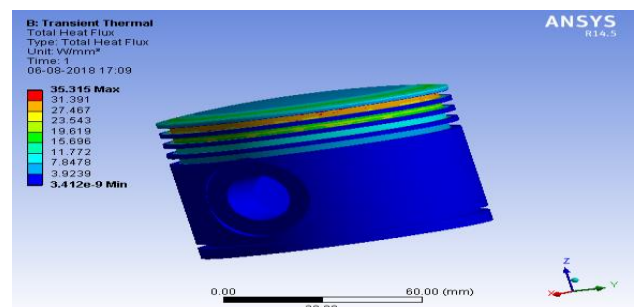

Fig3.5 : Temperature Distribution when piston material is Al-Alloy



GRAPH 3.1 : Time Vs Temperature when piston material is Al-Alloy

B) Heat Flux Distribution when piston material as Al- Alloy:



.Fig3.6 : Heat Flux Distribution when piston material is Al-Alloy

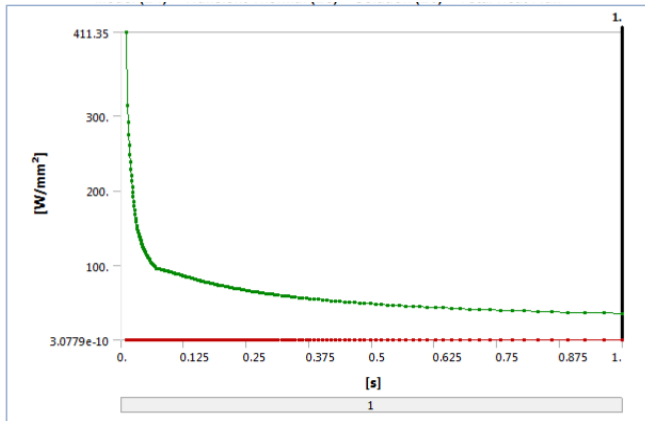

GRAPH 3.2 : Time Vs Heat Flux when piston material is Al-Alloy

Case 2 : A) Temperature Distribution when piston material as Ti- Alloy:

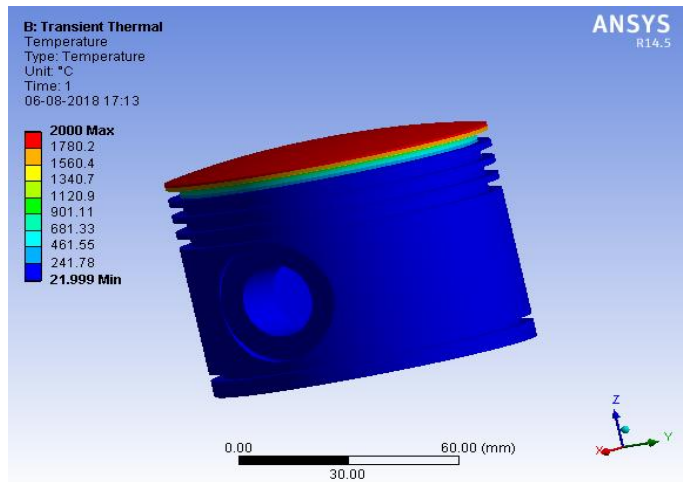
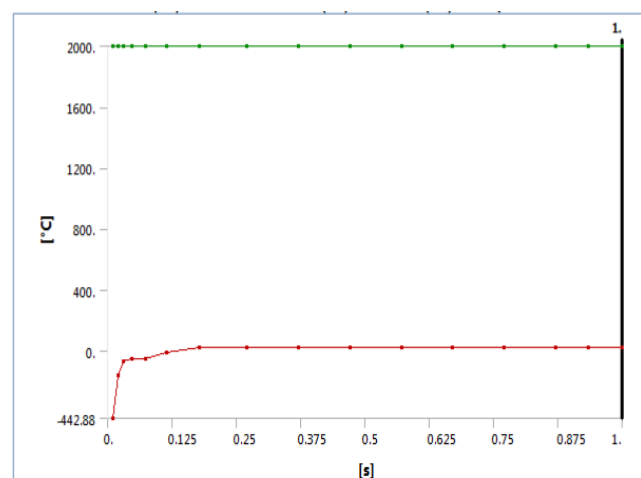

Fig3.7 : Temperature Distribution when piston material is Ti-Alloy



GRAPH 3.3 : Time Vs Temperature when piston material is Ti-Alloy

B) Heat Flux Distribution when piston material as Ti- Alloy:

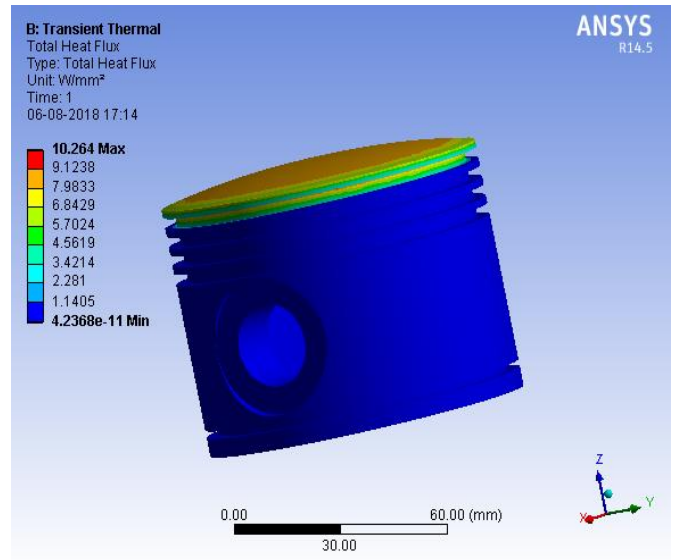
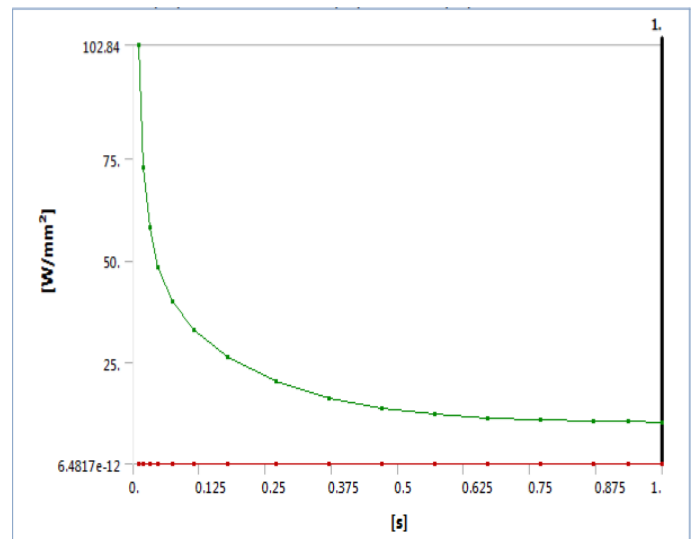

Fig3.8 : Heat Flux Distribution when piston material is Ti-Alloy .



GRAPH 3.4: Heat flux Vs Temperature when piston material is Ti-Alloy

3.1.2: The Temperature and Heat flux Distribution of piston with Thermal coating materials for one second has been observed. Also the temperature and heat flux distributions by time (1s) is shown graphically. Thermal coating on piston top surface with 1mm thickness has been applied with different coating materials such as Ni-Cr-Al and Mg-Zr-O₃.

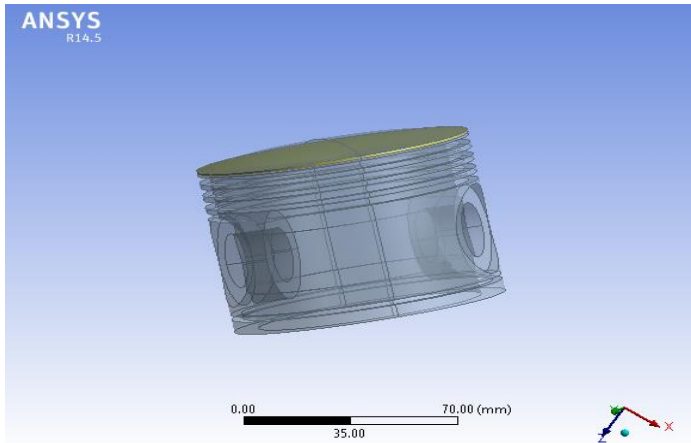

fig 3.9 :modal with 1mm thermal coating on top of the piston surface

B) Heat Flux Distribution when piston material as Al- Alloy & Coating Material As Ni-Cr-Al:

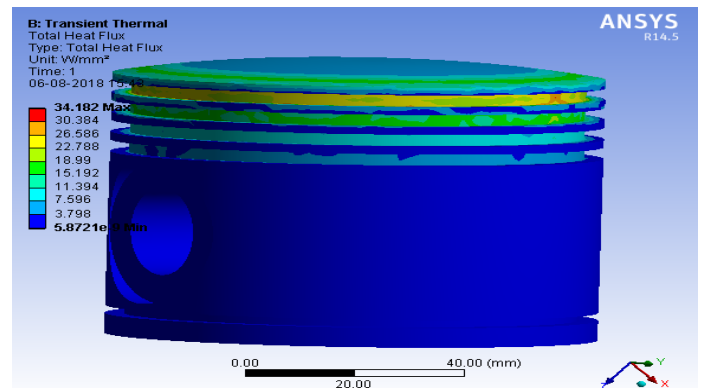

Fig 3.11: Heat Flux Distribution when piston material as Al- Alloy & Coating Material As Ni-Cr-Al

Case 1 : A) Temperature Distribution when piston material as Al- Alloy & Coating Material As Ni-Cr-Al

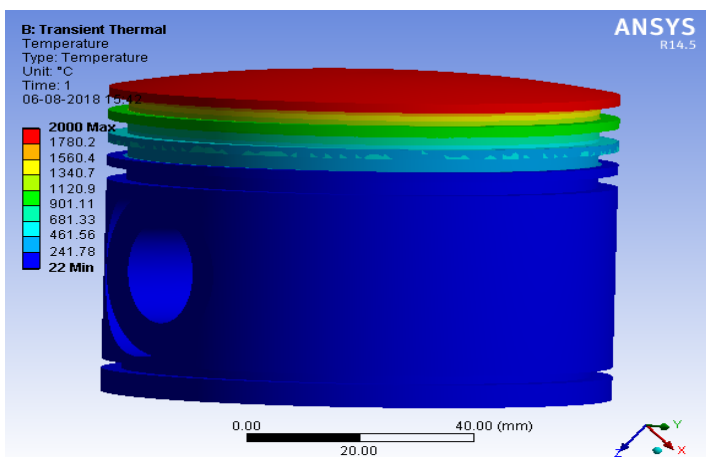
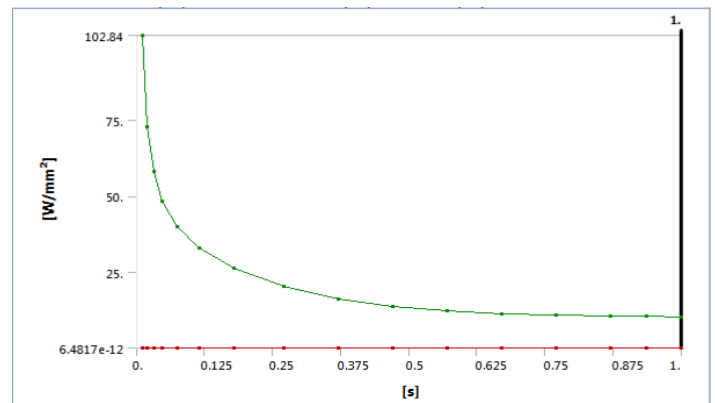

Fig 3.10: Temperature Distribution when piston material as Al- Alloy & Coating Material As Ni-Cr-Al



GRAPH 3.6: Time Vs Heat Flux when piston material as Al-Alloy & Coating Material As Ni-Cr-Al

Case 2 : A) Temperature Distribution when piston material as Al- Alloy & Coating Material As Mg-Zr-O₃.

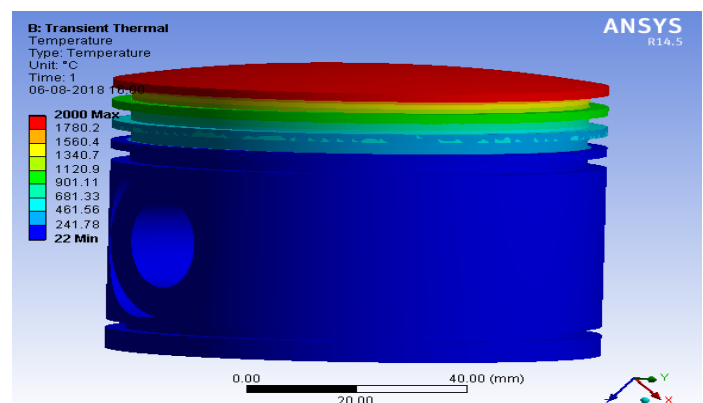
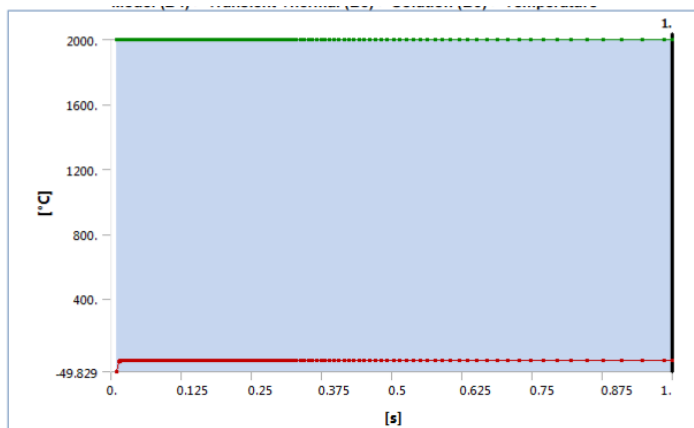
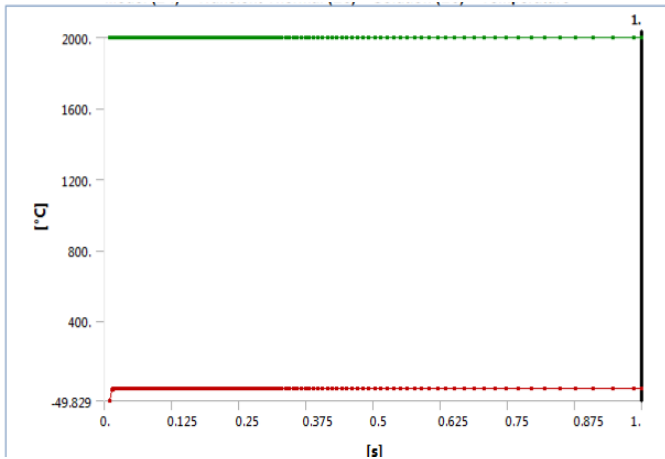

Fig.3.12 :Temperature Distribution when piston material as Al- Alloy & Coating Material As Mg-Zr-O₃.



GRAPH 3.5 : Time Vs Temperature when piston material as Al-Alloy & Coating Material As Ni-Cr-Al



GRAPH 3.7 : Time Vs Temperature when piston material as Al-Alloy & Coating Material As Mg-Zr-O₃.

Case 3 : A) Temperature Distribution when piston material as Ti -Alloy & Coating Material As Ni-Cr-Al.

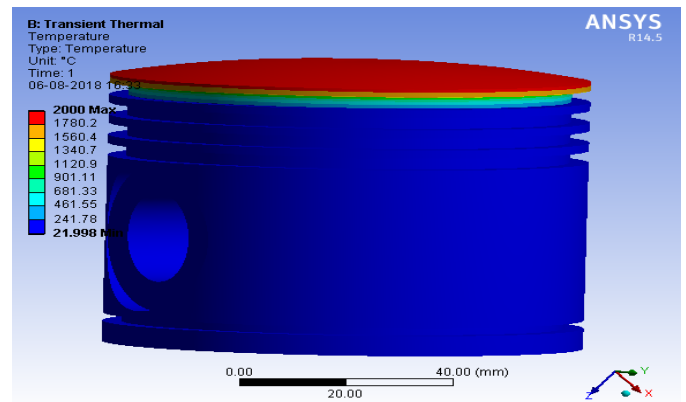

Fig.3.14 :Temperature Distribution when piston material as Ti -Alloy & Coating Material As Ni-Cr-Al.

B) Heat Flux Distribution when piston material as Al- Alloy & Coating Material As Mg-Zr-O₃.

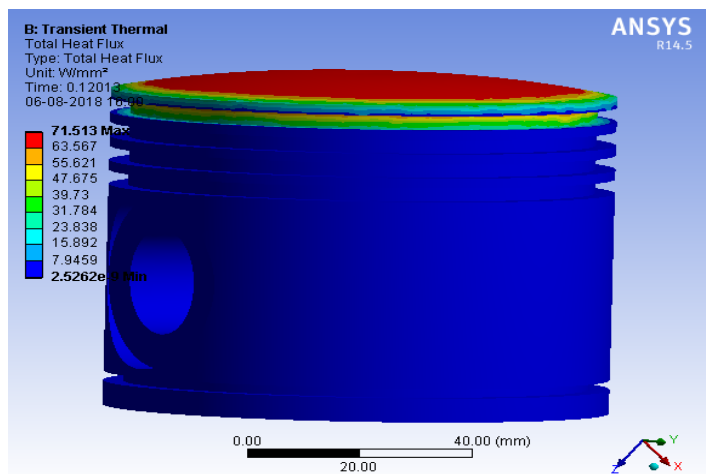
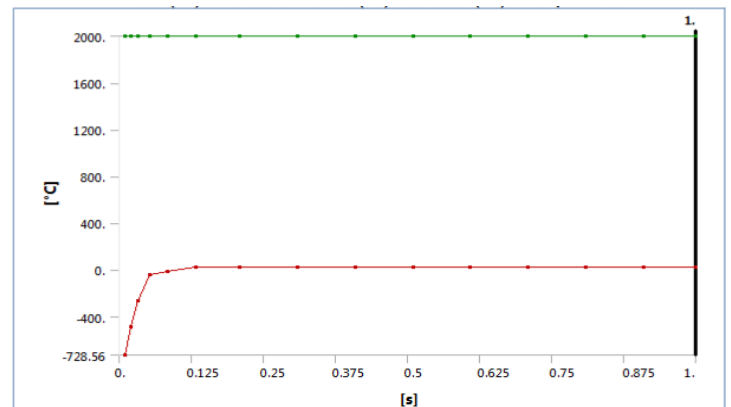

Fig.3.13 :Heat Flux Distribution when piston material as Al- Alloy & Coating Material As Mg-Zr-O₃.



GRAPH 3.9 : Time Vs Temperature when piston material as Ti-Alloy & Coating Material As Ni-Cr-Al

B) Heat Flux Distribution when piston material as Ti -Alloy & Coating Material As Ni-Cr-Al.

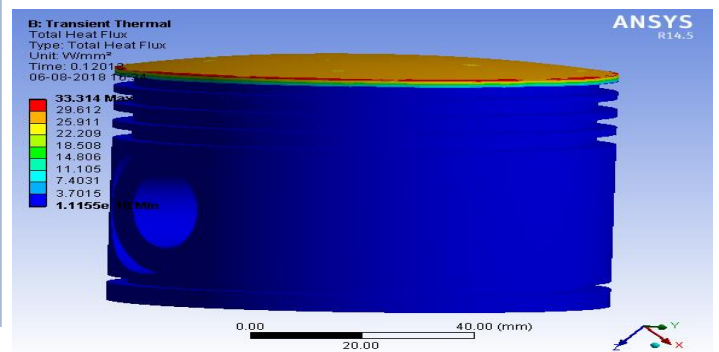
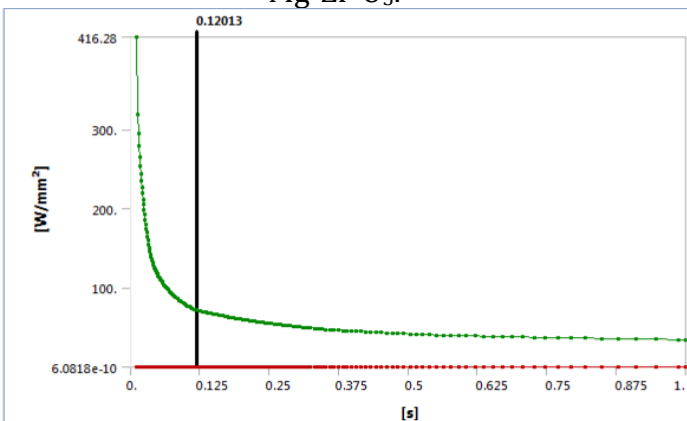
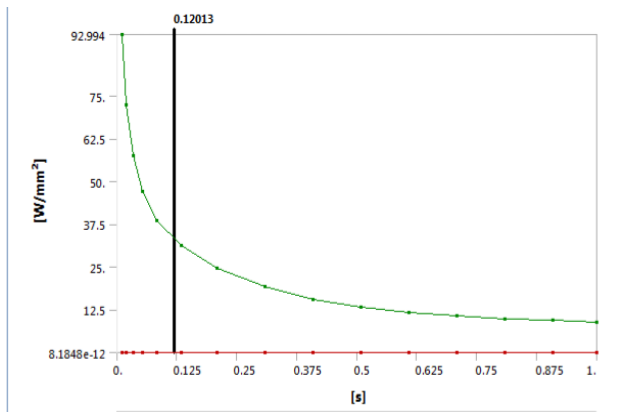

Fig.3.15 : Heat Flux Distribution when piston material as Ti -Alloy & Coating Material As Ni-Cr-Al.



GRAPH 3.8 : Time Vs Heat Flux when piston material as Al-Alloy & Coating Material As Mg-Zr-O₃.



GRAPH 3.10: Time Vs Heat Flux when piston material as Ti-Alloy & Coating Material As Ni-Cr-Al

Case 4: A) Temperature Distribution when piston material as Ti-Alloy & Coating Material As Mg-Zr-O₃

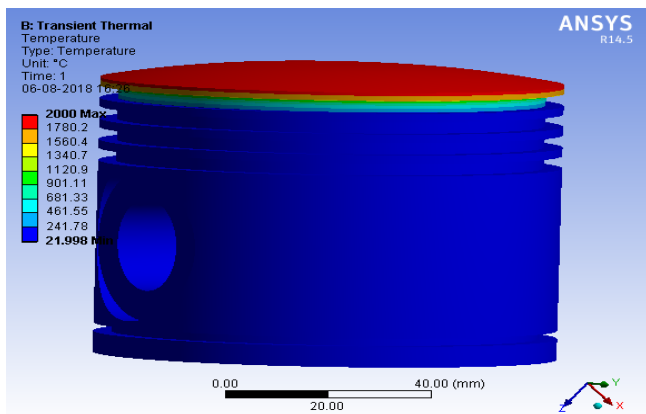
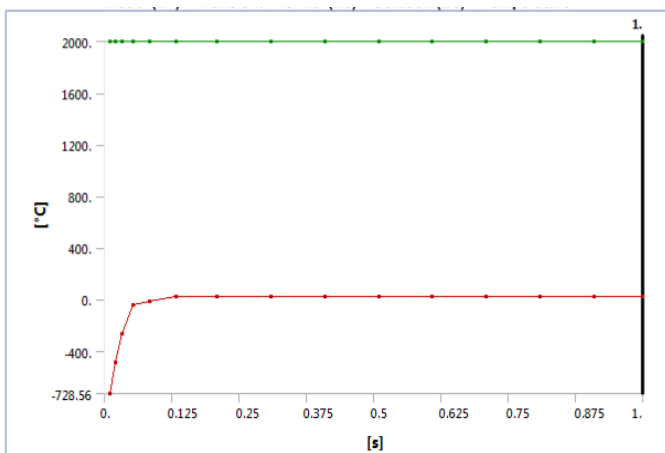

Fig 3.16: Temperature Distribution when piston material as Ti-Alloy & Coating Material As Mg-Zr-O₃



GRAPH 3.11 : Time Vs Temperature when piston material as Ti-Alloy & Coating Material As Mg-Zr-O₃.

B) Heat Flux Distribution when piston material as Ti-Alloy & Coating Material As Mg-Zr-O₃

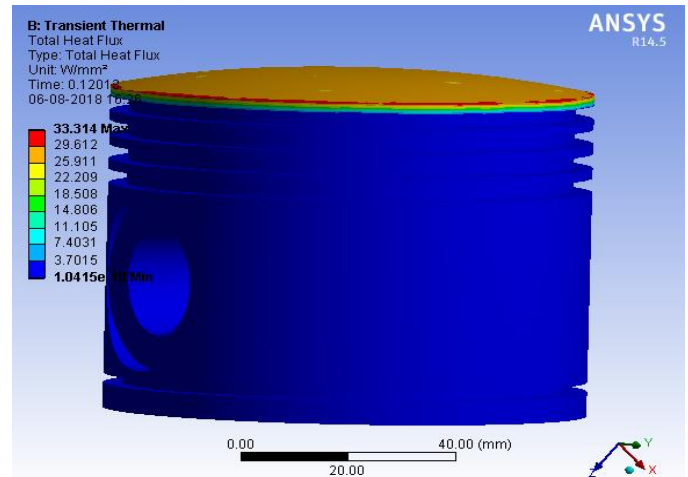
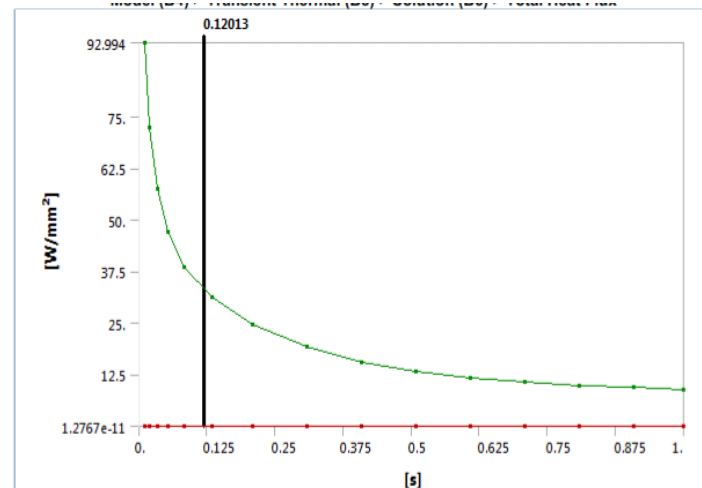

Fig.3.17 :Heat Flux Distribution when piston material as Ti-Alloy & Coating Material As Mg-Zr-O₃



GRAPH 3.12: Time Vs Heat Flux when piston material as Ti-Alloy & Coating Material As Mg-Zr-O₃

4. RESULTS AND DISSCUSSIONS :

In this present work we selected ,Al- Alloy and Ti-Alloy materials are used as piston materials and Ni-Cr-Al and Mg-Zr-O₃ materials as coating materials.

Also tested the heat flux distribution with different combination of piston material and coating material from the above mentioned materials. The results were tabulated as fallows.

S.No	Material	Min heat flux value (w/mm ²)	Max heat flux value (w/mm ²)
1.	Al- Alloy	3.412e-9	35.315
2.	Ti-Alloy	4.2368e-11	10.264
3.	Al-alloy with Ni-Cr-Al	5.8721e-9	34.182
4.	Al-alloy with Mg-Zr-O ₃	2.5262e-9	71.513
5.	Ti-alloy with Ni-Cr-Al	1.1155e-10	33.314
6.	Ti-alloy with Mg-Zr-O ₃	1.0415e-10	33.314

The piston made with Aluminum alloy without coating ,will not providing much heat distribution at any instant.

similarly, The piston made with Titanium alloy without coating also not providing much heat distribution at any instant.

The maximum heat flux distribution obtained when Al-Alloy is piston material and Mg-Zr-O₃ as coating material which is equal to 71.513 W/mm². so the Mg-Zr-O₃ Coating material is preferable compared to other.

5. CONCLUSIONS AND FUTURE SCOPE

In this present work we selected ,Al- Alloy and Ti-Alloy materials are used as piston materials and Ni-Cr-Al and Mg-Zr-O₃ materials as coating materials. The heat flux distribution with different combination of piston material and coating material from the above mentioned materials has observed. At the initial stage the temperature applied to the piston crown is 2000 ° c. and the convection het transfer distribution was observed as fallows.

The Temperature and Heat flux Distribution of piston with & without Thermal coating materials for one second has been observed. also the temperature and heat flux distributions by time (1s) is shown graphically.

conclusions :

- The piston made with Aluminum alloy without coating ,will not providing much heat distribution at any instant.
- similarly, The piston made with Titanium alloy without coating also not providing much heat distribution at any instant.
- The maximum heat flux distribution obtained when Al-Alloy is piston material and Mg-Zr-O₃ as coating material which is equal to 71.513 W/mm².
- so the Mg-Zr-O₃ Coating material is preferable compared other.

Future scope:

- The test can be extended by selecting more different piston materials those are very much convective in nature.
- This work can be extended by selecting suitable coating materials other than Ni-Cr-Al and Mg-Zr-O₃.
- The simulation results can be compared with experimental results to decide better material for better heat flux distribution.
- The project can be extended by varying the thickness of coating and able to identify which will provide more heat distribution.
- The convection temperature can be assumed more than 2000⁰c , which is rare in in some high speed engines.

ACKNOWLEDGEMENT

The authors can acknowledge any person/authorities in this section. This is not mandatory.

REFERENCES

1. S Pal, A Deore, A Choudhary, V Madhwani and D Vijapuri, -“Analysis and experimental investigation of ceramic powder coating on aluminum piston”, IOP Conference Series: Materials Science and Engineering, 14TH ICSET 2017, 263 062071.
2. Valentin Mereuta -“ Static and Thermal Analysis of Piston using FEM Analysis”, International Journal for Research in Applied Science &

Engineering Technology (IJRASET), ISSN: 2321-9653; IC Value: 45.98; SJ Impact Factor :6.887 ,Volume 6 Issue I, January 2018- PAGE 201-206.

3. Dr.I.Satyanarayana , N. Rajyalaxmi ,“ Thermal Analysis of Ceramic Coated Steel Alloy Piston Used in Diesel Engine Using FEM”, IJISSET - International Journal of Innovative Science, Engineering & Technology, Vol. 3 Issue 9, September 2016 ,ISSN (Online) 2348 – 7968 | Impact Factor (2015) - 4.332, PAGE 245-250.

4. K.S.Mahajan* and S.H.Deshmukh, “Structural and Thermal Analysis of Piston”, International Journal of Current Engineering and Technology E-ISSN 2277 – 4106, P-ISSN 2347–5161, INPRESSCO®, Special Issue-5 (June 2016), PAGE 22-29.

5. Mallavarapu Nageswari , Vijaya Kumar, “Thermal & Static Analysis On Ic Engine Piston Using Fea”, IJARSE, Vol.No. 4, Issue No. 12, December 2015, ISSN 2319-8354.PAGE 244-250.

6. Balbheem Kamanna, Prof. Bibin Jose, Ajay Shamrao Shedage, Sagar Ganpat Ambekar, Rajesh Somnath Shinde, Sagar Landge -“Thermal barrier coating on IC Engine Piston to improve Engine efficiency”, International Journal of Scientific & Engineering Research, Volume 8, Issue 3, March-2017, ISSN 2229-5518, page 250-253.

7. Jatender Datta & Dr. Sahib Sartaj Singh-“Thermal Analysis On Piston Of Various Materials And Comparison With Each Other’s By Using Finite Element Analysis Technique”, IJESRT, ISSN : 2277-9655,SEPTEMBER-2017, PAGE.NO 231-239.

8. Mr.Bhavin D. Patel, Prof.Ramesh N. Mevada, Prof. Dhaval P. Patel-“Review of Literature Survey on Effect of Thermal Coating on Cylinder and Piston Crown”, International Journal of Engineering Research and General Science Volume 2, Issue 6, October-November, 2014, ISSN 2091-2730, PAGE.NO.740-745.

9. Mangal Mai Shukla, Om Prakash Tiwari, -“Design and thermal analysis of ceramic coated Mercedes Benz piston”, IJARIT, ISSN: 2454-132X, Volume 4, Issue 4, PAGE.NO. 141-148.

10. Dipayan Sinha, Susenjit Sarkar and Samar Chandra Mandal,“ Thermo Mechanical Analysis of a Piston with Different Thermal Barrier Coating Configuration”, International Journal of Engineering Trends and Technology (IJETT) – Volume 48 Number 6 June 2017, PAGE.NO. 335-349.

11. Manish Kumar,“ A Finite Element Thermo-Mechanical Stress Analysis of IC Engine Piston”, International Research Journal Of Engineering And Technology (Irjet) E-Issn: 2395 -0056, P-Issn: 2395-0072, Volume 4, Issue 6, PAGE .No. 1976-1981.

12. Thirakavinod Kumar, B. Ravisekhar -“Thermal & Static Analysis On Ic Engine Piston Using Fea”, IJATES,Issn2348-7550,Volume 4, Issue No. 12,December-2016, Page. No. 225-231.

13. M.X. Calbureanu, R. Malciu, D. Tutunea, A. Ionescu and M. Lungu,“ The finite element analysis of the thermal stress distribution of a piston head”, International Journal Of Mechanics, Issue 4, Volume 7, 2013, PAGE.NO. 467-473.

14. Hojjat Ashouri “Thermal barrier coating effect on stress and temperature distribution of diesel engines cylinder heads using a two layer viscoelasticity model with considering viscosity effects” International Journal of Automotive Engineering Vol. 7, Number 2, June 2017, PAGE.NO. 2381-2392.

15. Vishal Kumar Shrivastava Prof. Alok Agrawal , “Thermal Analysis of a Diesel Piston with different material parameter”, International Journal of Advanced Scientific and Technical Research Issue 7 volume 2 March-April 2017, ISSN 2249-9954, PAGE.NO. 214-225.

[1] D. Kornack and P. Rakic, “Cell Proliferation without Neurogenesis in Adult Primate Neocortex,” *Science*, vol. 294, Dec. 2001, pp. 2127-2130, doi:10.1126/science.1065467.

[2] M. Young, *The Technical Writer’s Handbook*. Mill Valley, CA: University Science, 1989.

[3] R. Nicole, “Title of paper with only first word capitalized,” *J. Name Stand. Abbrev.*, in press.

- [4] K. Elissa, "Title of paper if known," unpublished.

BIOGRAPHIES



I **Syed Arif Ali** ,persuing **M.Tech (CAD/CAM)** in Wits, Warangal.



I **Nalla Suresh** completed M.Tech (CAD/CAM) from Kakatiya University. presently working as an Assistant Professor in wits, Warangal since last two years. Totally i have three years of teaching experience and two years of industrial experience. Having very good knowledge and skill in all mechanical Design software's and very much interest in accepting the challenges in working.



I **Elumagandla Surendar**, **HOD & Associate Professor** of MED , WITS ,Having 11 years of teaching experience and 4 years of industrial experience. More interest in teaching especially Thermal engineering subjects and administration.