

# COMBINED AIR REFRIGERATION, AIR CONDITIONING AND WATER DISPENSER SYSTEMS

<sup>1</sup> Prof. Sunil A More, <sup>2</sup> Vivek Paul, <sup>3</sup> Shashi Shoumya, <sup>4</sup> Vinay Kumar, <sup>5</sup> Nitesh Kumar

<sup>1</sup>Prof. Mechanical Department, D.Y. Patil College of Engg. Ambi, pune-410507

<sup>2,3,4,5</sup> Student of Mechanical Engineering, D.Y. Patil College of engg. Ambi, pune-410507

\*\*\*

**Abstract** – This project “Combined Air Refrigeration, Air Conditioner and Water Dispenser systems” deals with the study of air conditioner, air refrigeration and water dispenser system in a single unit. The main object behind this project is to develop the multifunctional system which can provide cold water, refrigeration effect and air conditioning effect with regular air/space conditioning system. The design mainly consists of compressor, condenser, expansion valve and other accessories (back pressure valve and diffuser). The refrigerant is used as a medium which absorbs the heat from the low temperature system and discards the heat so absorbed to a higher temperature system. This transfer of heat is used in a sensible manner to bring out the various heating and cooling effect. Common condenser and common compressor feeds the system having separate evaporators. Systematic analysis of the project was carried after its completion. The various performance characteristics were checked in’ cool pack software for various inputs. Various design and operations were modified with a view to save space, initial and maintenance costs.

**Key Words:** Compressor; Condenser; Expansion valve (capillary tube); evaporator; Back pressure valve; diffuser; cool pack software

## 1. INTRODUCTION

Due to increase in the temperature of the earth because of the global warming, the use of the air conditioning has become an essential part for all human beings. Refrigeration is basically the changing of phase refrigerant to get heating and cooling effect from it. Earlier air was used as a refrigerant. Since air does not change its phase, i.e, and remains gaseous state throughout the cycle, therefore heat carrying capacity per kg of air is very small as compared to vapour absorbing systems. The air cycle refrigeration system, as originally designed and installed, are now practically obsolete because of their low coefficient of performance and high power requirement.

The advent of high speed passenger aircraft, jet aircraft and missiles has introduced the need of the compact and simple refrigeration systems, with minimum reduction of the payload.

At present in the market we have the separate form of the water cooler, air conditioner and air refrigeration system. All three of them work on the same principle. Moreover, the standard of the people have improved. They all have installed these three equipment’s in their homes, offices, and living room and many more. But the most disadvantages are that they have high electrical consumption which makes people worry about it.

So the attractive point of our project is that it can provide all these facilities in compact way with lesser electrical consumption in a single unit.

## 2. LITERATURE REVIEW

[1] Prof. S.M. Sheikh, et al. Published journal (IOSR\_JMCE) “Performance Investigation of Window Air Conditioner” in this journal he is studied the proper definition of air conditioning system and the advantages and application of air conditioning system. Also by the calculation he determines the all parameters related to the air conditioning system and based on that he consider the specification for this unit.

[2] P. Dasthagiri, et al. Published paper (2015) “Fabrication and Analysis of Refrigerator Cum Chilled Water Dispenser” in this paper he is studied that why the combine system is required, we can cooled or freeze water with help of refrigerator.

[3] Himanshu, et al. Published paper (2014), “Feasibility Study and Development of Refrigerator Cum Air Conditioner” in this paper he is studied that combine system of refrigerator with air-conditioner.

[4] B. Naveen, et al. Published paper (2013), “Waste Heat Recovery in R & Ac Systems” This report deals with design and fabrications of a three in one air conditioner.

[5] Dr. U. V.Kongre, A. R. Chiddarwar, et al. Published paper (2013) “Testing and Performance Analysis on Air Conditioner cum Water Dispenser” The paper introduced basic design principles and the test analysis performed in the laboratory. The paper also introduced comfort conditions and suitable coefficient of performance with respect to atmospheric condition, without sacrificing the air conditioning output.

### 3. Working Principles

Before the basic component of the “ combined air refrigeration , air conditioner and water dispenser system” are compressor , condenser, expansion valve and evaporator, back pressure valve and diffuser.

#### 3.1 Compressor

It is the machine which is used to compress the vapours refrigerant from the evaporator and to raise its pressure so that the corresponding saturation temperature is higher than that of the cooling medium. It also continually circulates the refrigerant through the refrigeration system. Since the refrigeration of the system requires some work to be done on it, therefore must be driven by some prime mover.



Fig: Compressor

#### 3.2 Condenser

It removes the heat of the hot vapors refrigerant discharged from the compressor. The heat from the hot vapor refrigerant in a condenser is removed first by transferring it to the walls of the condenser tubes and then from the tubes to the condensing and cooling medium. The cooling medium may be air or water or a combination of these two.

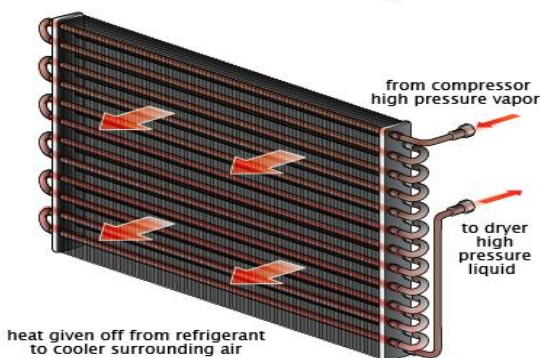

Image courtesy of ClearMechanic.com

Fig: Condenser

#### 3.3 Expansion device

It is also called metering device or throttling device. It divides the high pressure side and the low pressure side of the system and maintains the desired pressure between them. It controls the flow of the refrigerant according to the load on the evaporator.

It reduces the high pressure liquid refrigerant to low pressure liquid before being fed to evaporator.



Fig: Expansion device

#### 3.4 Evaporator

Evaporator absorbs heat from the surrounding location or medium which is to be cooled by means of the refrigerant. The refrigerant enters the evaporator where it boils and changes into vapor. The temperature in the evaporator must always be less than that of the surrounding medium so that heat flows to the refrigerant.



Fig: Evaporator

#### 3.5 Back Pressure Valve

When the refrigerant is passed through the evaporating coil the mass flow of the refrigerant is different for the combine system. After evaporation the refrigerant is passed to the compressor, at that time, refrigerant from three evaporating coil is collected in capillary tube and pass to the compressor. To maintain the mass flow rate back pressure valve is used.

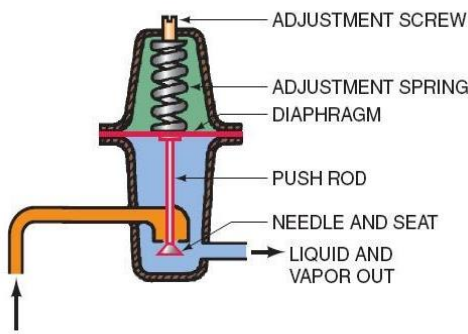

Fig. Back Pressure Valve

- Compressor converts the low pressure and low temperature vapour refrigerant to high pressure and high temperature vapour refrigerant.
- In condenser, high pressure and high temperature vapour refrigerant gets converted to high pressure and low temperature liquid refrigerant.
- Diffuser valve maintains the flow of the refrigerant in the respective compartment.
- In expansion valve, high pressure and low temperature liquid refrigerant gets converted to low pressure and low temperature liquid refrigerant.
- In evaporator, these low pressure and low temperature liquid refrigerant gets converted to low pressure and low temperature vapour refrigerant, which is again feed to compressor and thus cycle repeats itself.
- Back pressure valve maintains the equal proportion of the refrigerant to avoid load on the compressor.

### 3.6 Diffuser Valve

The three units are installed in a single unit and hence for effective working of these units, it is important some mechanism is used to be installed which would control the amount of the refrigerant into the system. For these purpose capillary tubes of different diameter are connected in diffuser valve. Thus, diffuser valve maintains the correct quantity of the refrigerant in three compartments.

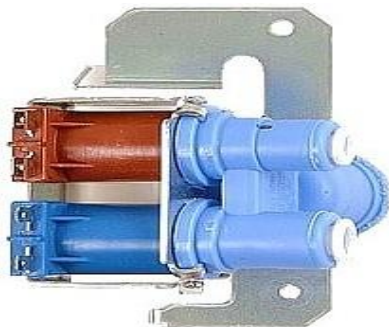
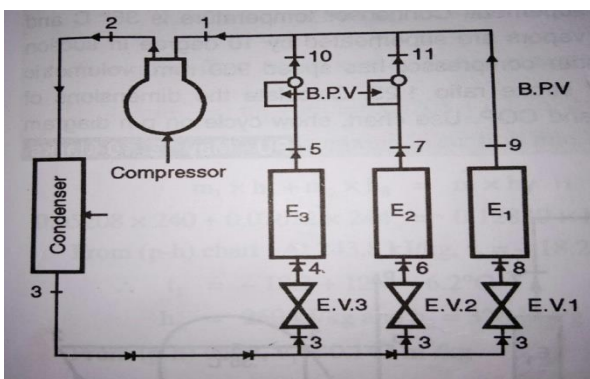

Fig. Diffuser Valve of water cooler

### 4. Experimental set up layout



E: evaporator  
E.V: expansion valve  
B.P.V: back pressure valve

Fig: combined refrigeration system

### 5. DESIGN SPECIFICATION

#### 5.1 HEAT TRANSFER BY CONDEENSER

Heat transfer by condenser is given by  
 $Q = KA (t_{co} - t_{ci})$

Where,

A= surface area of the condenser= $\pi D L$

D=diameter of the condenser tube

K= Thermal conductivity of the copper tube=386w/mk

T<sub>co</sub>=condenser outlet temperature

T<sub>ci</sub>=condenser inlet temperature

Therefore,

$$Q = 386 * (\pi * 0.01) * \{30 - 16.6329\}$$

$$Q = 162.09677 \text{ W}$$

But

We know that

$$Q = M C_p (t_{co} - t_{ci})$$

Where C<sub>p</sub>= specific heat at constant pressure

Therefore

$$162.09677 = M * 1.022 * 1000 (30 - 16.6329)$$

$$M = 0.01186 \text{ Kg/s}$$

#### 5.1.1 AREA OF THE CONDENSER TUBE

$$A = \pi D L$$

Where

L=length of the condenser tube

A=cross sectional area of the condenser tube

Therefore

$$A = \pi * 0.1 * 7$$

$$A = 0.2199 \text{ m}^2$$

## 5.2 EVAPORATOR SPECIFICATION

Heat transfer by evaporator is given by

$$Q = K \cdot \pi \cdot d \cdot (t_{e0} - t_{ei})$$

Where

$K$  = thermal conductivity of the copper tube = 386 W/m<sup>2</sup>k

$t_{e0}$  = outlet temperature of the evaporator

$t_{ei}$  = inlet temperature of the evaporator

$$Q = 386 \cdot \pi \cdot 6.35 \cdot 10^{-3} \cdot \{16.6329 - (-7)\}$$

$$Q = 181.9817 \text{ W}$$

But we know that

$$Q = m \cdot c_p \cdot (t_{e0} - t_{ei})$$

Where  $c_p$  = specific heat at constant pressure

Therefore

$$181.9817 = m \cdot 0.960 \cdot 1000 \cdot \{16.6329 - (-7)\}$$

$$M = 0.0083236 \text{ Kg/s}$$

### 5.2.1 AREA OF THE EVAPORATOR TUBE

Area of the evaporator tube is given by

$$A = \pi \cdot d \cdot L$$

$$A = \pi \cdot 6.35 \cdot 10^{-3} \cdot 11$$

$$A = 0.2194 \text{ m}^2$$

## 5.3 SPECIFICATION OF THE COMPRESSOR

Compressor KCJ511HAE B420

230V-50Hz-1P-LRA25-R-22

Thermally protected hermetically sealed compressor is selected.

## 6. PERFORMANCE CHARACTERISTICS THROUGH COOL PACK SOFTWARE

### 6.1 SPECIFICATION OF THE CYCLE THROUGH COOL PACK SOFTWARE

CYCLE SPECIFICATION			
TEMPERATURE LEVELS		PRESSURE LOSSES	
$T_E$ [°C]: -7.0	$\Delta T_{SH}$ [K]: 5	$\Delta P_{SL}$ [k]: 0.5	No SGHX 0.30
$T_C$ [°C]: 16.6	$\Delta T_{SC}$ [K]: 2	$\Delta P_{DL}$ [k]: 0.5	
REFRIGERANT: R22			
CYCLE CAPACITY			
Cooling capacity $\dot{Q}_E$ [kW]: 19.1	$\dot{Q}_E$ : 19.1 [kW]	$\dot{Q}_C$ : 20.64 [kW]	$\dot{m}$ : 0.1012 [kg/s]
$\dot{V}_S$ : 22.64 [m <sup>3</sup> /h]			
COMPRESSOR PERFORMANCE			
Isentropic efficiency $\eta_{IS}$ [-]: 0.7	$\eta_{IS}$ : 0.700 [-]	$\dot{W}$ : 2.822 [kW]	
COMPRESSOR HEAT LOSS			
Discharge temperature $T_2$ [°C]: 30	$f_0$ : 49.0 [%]	$T_2$ : 30.0 [°C]	$\dot{Q}_{LOSS}$ : 1.384 [kW]
SUCTION LINE			
Unuseful superheat $\Delta T_{SH,SL}$ [K]: 1.0	$\dot{Q}_{SL}$ : 85 [W]	$T_8$ : -1.0 [°C]	$\Delta T_{SH,SL}$ : 1.0 [K]

Fig: cycle specification

## 6.2 Diagrammatic representation of R22

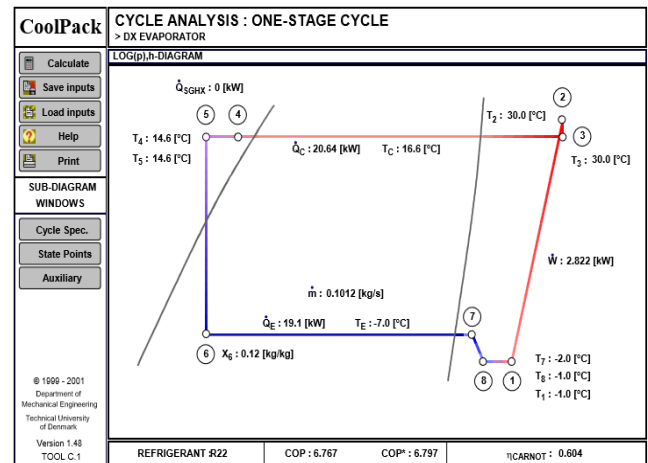

Fig p-h graph of R-22

## 6.3 Various State Points

STATE POINTS				
STATE POINT	TEMPERATURE [°C]	PRESSURE [kPa]	ENTHALPY [kJ/kg]	DENSITY [kg/m <sup>3</sup> ]
1	-1.0	386.4	251.6	16.1
2	30.0	838.6	265.8	33.0
3	30.0	826.7	266.1	32.4
4	14.6	826.7	62.1	1233.2
5	14.6	826.7	62.1	1233.2
6	-7.0	393.2	62.1	-----
7	-2.0	393.2	250.8	16.5
8	-1.0	386.4	251.6	16.1

Fig: temperature, pressure at various points

## 6.4 Other Auxiliaries Information through Cool Pack

AUXILIARY			
VOLUMETRIC EFFICIENCY			
Volumetric efficiency $\eta_{VOL}$ [-]: 0.8	$\eta_{VOL}$ : 0.800 [-]	$\dot{V}_S$ : 22.64 [m <sup>3</sup> /h]	$\dot{V}_D$ : 28.3 [m <sup>3</sup> /h]
UTILIZATION OF DISCHARGE GAS SUPERHEAT FOR HEATING OF WATER			
Temperature increase $\Delta T_{WATER}$ [K]: 20	$\Delta T_{WATER}$ : 20 [K]	$\dot{V}_{WATER}$ : 0.04589 [m <sup>3</sup> /h]	$\dot{Q}_{D,SH}$ : 1.067 [kW]
$T_{D,OUT}$ : 30.0 [°C] $T_C$ : 16.6 [°C]			
ENERGY CONSUMPTION			
Hours of operation [h]: 8760		Energy consumption: 24724 [kWh]	
PIPE DIMENSIONS			
PIPE SECTION	VELOCITY [m/s]	PIPE DIAMETER (Internal) [mm]	Condition corresponds to
Suction line	10.0	28.3	State Point #1
Discharge line	12.0	18.0	State Point #2
Liquid line	0.6	13.2	State Point #5

## 6.5 ADDITIONAL INFORMATION

Pressure ratio	$P_2/P_1=2.170$
(Discharged temp.)reversible and adiabatic compression	36.8°C
(Discharged temp.)real and adiabatic compression	47.6°C

Fig: Additional information of the process

## 7 RESULTS AND DISCUSSION

### 7.1 WORK DONE BY THE COMPRESSOR

Considering mass 1 kg

$$W_c = (h_2 - h_1)$$

$$W_c = (421.9 - 402.8)$$

$$W_c = 19.1W$$

### 7.2 HEAT REJECTED BY THE CONDENSER

Heat rejected by the condenser is given by

$$Q_{\text{rejected}} = (h_2 - h_3)$$

$$Q_{\text{rejected}} = (421.9 - 219.923)$$

$$Q_{\text{rejected}} = 201.977W$$

### 7.3 REFRIGERATION EFFECT

Refrigeration effect is given by

$$R.E. = (h_1 - h_4)$$

$$R.E. = (402.8 - 219.923)$$

$$R.E. = 182.877W$$

### 7.4 COEFFICIENT OF PERFORMANCE (C.O.P.)

$$C.O.P. = R.E./W_c$$

$$C.O.P. = 182.877/19.1$$

$$C.O.P. = 9.57$$

Considering compressor to have isentropic efficiency of 70%

Therefore, C.O.P. of the system is  $(9.57 \times 0.7) = 6.69$

$$C.O.P. = 6.69$$

## 8. CONCLUSIONS

From the above prototype the three in one system is one of the reusable and eco-friendly projects which can be implemented in our day to day life for the effective management of power consumption factor. Hence it plays the major role for the people who are living in the desert regions. This is one maiden venture in the field of the

refrigeration system from the stream of mechanical engineering as terms lead to change in the recent trend to the favor of ecological systems.

## 9. ACKNOWLEDGEMENTS

We wish to express our profound thank to our project guide Prof. S.A. More for his dedication for the project. Discussing our project ideas and spending is valuable time with us in solving any hurdles that arises in due course of the project.

We are extremely grateful to the Head of the Department, Dr. S.V.Channappattana for having encouraged and helped us throughout the course of the project.

## 10. REFERENCES

[1] S.M. Shaikh, "Performance Investigation of Window Air Conditioner" IOSR Journal of Civil and Mechanical Engineering (IOSR-JMCE) sISSN: 2278-1684, PP: 32-37www.iosrjournals.org Second

[2] P.Dasthagiri and H.Ranganna, "Fabrication and Analysis of Refrigerator cum Chilled Water Dispenser" Advanced Engineering and Applied Sciences: An International Journal, ISSN 2320-3927

[3] Himanshu, "Feasibility Study and Development of Refrigerator cum Air Conditioner" International Journal of Scientific and Research Publications, Volume 4, Issue 12, December 2014 1 ISSN 22503153 .

[4] Dr. U. V.Kongre and A. R. Chiddarwar, "Testing and Performance Analysis on Air Conditioner cum Water Dispenser" International Journal of Engineering Trends and Technology (IJETT) - Volume4Issue4- April 2013

[5] B. Naveen, "waste heat recovery in r & ac systems" international journal of science and research (ijsr) ISSN (online): 2319-7064

[6] <https://www.quora.com/What-is-the-suction-and-discharge-pressure-for-a-1-ton-Air-Conditioner-Compressor-working-on-R-22>

## BIOGRAPHIES



**Vivek Paul** is now pursuing his Bachelor of Engineering in Mechanical Engineering at D. Y. Patil College of Engineering Academy, Ambi, Pune.



**Shashi Shoumya** is now pursuing his Bachelor of Engineering in Mechanical Engineering at D. Y. Patil College of Engineering Academy, Ambi, Pune.



**Vinay Kumar** is now pursuing his Bachelor of Engineering in Mechanical Engineering at D. Y. Patil College of Engineering Academy, Ambi, Pune.



**Nitesh Kumar** is now pursuing his Bachelor of Engineering in Mechanical Engineering at D. Y. Patil College of Engineering Academy, Ambi, Pune.



**Prof. Sunil More**  
Assistant Professor  
Department of Mechanical  
Engineering  
D.Y. Patil College of Engineering,  
Ambi, Pune.