

Design and Fabrication of Multipurpose Agro System

Prof. P.V.Bute¹, Shailesh Deshmukh², Govind Rai³, Chetan Patil⁴, Vishal Deshmukh⁵

¹Professor, Dept. of Mechanical Engineering, SRTTC Khamshet, Maharashtra, India

^{2,3,4,5} Dept. of Mechanical Engineering

Abstract - An agricultural mechanism or agri mechanism could be a mechanism deployed for agricultural functions. the most space of application of robots in agriculture is seeding robots square measure designed to exchange human labor. The agricultural business is behind alternative complementary industries in victimization robots as a result of the kind of jobs concerned in agriculture are not any and dig.

This project strives to develop a mechanism capable of activity operations like automatic seeding and dig. It additionally provides manual management once needed and keeps tabs on the wetness with the assistance of wetness sensors. Then main part here is that the microcontroller that supervises the whole method.

Keywords: Agriculture, microcontroller, Plough, Seeder.

1. INTRODUCTION

Farmers nowadays pay plenty of cash on machines that facilitate them decrease labor work and increase yield of crops. There square measure numerous machines that square measure offered for tilling, harvesting, spraying pesticides etc., but these machines ought to be operated by hand to perform the specified operations and furthermore separate machines square measure used for each functions. The yield and profit returns from using this instrumentation square measure terribly less as compared to the investment. Another issue is that the growing demands of the world's population. the planet Health Organization estimates that Earth's population can bit nine billion in thirty five years which can cause a staggering demand in increase of growth of food crops. Automation is that the ideal resolution to beat all the on top of mentioned shortcomings by making machines that perform quite one operation and automating those operations to extend yield on an outsized scale.

As one of the trends of development on automation and intelligence of agricultural machinery within the twenty first century, all types of agricultural robots are researched and developed to implement variety of agricultural production in several countries, like choosing, harvesting, weeding, pruning, planting, grafting, agricultural classification, etc. and that they step by step seem benefits in agricultural production to extend productivity.

Autonomous agricultural robots square measure an alternate to the tractors found on fields nowadays. A cultivation task like seeding, spraying, fertilizing and gather

is also performed by fleets of autonomous agricultural robots within the future. freelance of the particular style a heavy agricultural mechanism are a posh and big-ticket vehicle – the challenge is thus to prove that it's competitive to ancient technology and will even bring a decisive lead.

1.1 problem statement

- Design and develop an agricultural robot which can be able to seeding and digging carried out in agricultural field. The control of this agri-robot should be wireless and can be able to show above operations.

- Fabricate the model of same operated by wireless control which able to show above mentioned operations like seeding and digging.

- Also design and analyze a real time system for this robot to give a solution and propose a model which can be used in real time field.

1.2 objectives

- To Design and develop an agricultural robot which can be able to digging and seeds like operations carried out in agricultural field.

- To control of this agri-robot should be wireless and can be able to show above operations.

- Design and analyze a real time system for this robot to give a solution and propose a model which can be used in real time field.

- Analyze the design of digging tool and develop for real time system.

- To propose a low cost but effective real time agri-robot system.

2. LITERATURE REVIEW

Shivaprasad B S, Ravishankara M N, B N Shoba[1]

In trendy globalisation, several technologists are attempting to update a replacement development supported automation that works terribly stiffly, high effectively and inside short fundamental quantity. The progressive invention in agriculture system is changing into a very important task particularly owing to rising demand on quality of agriculture

product and declining labor accessibility in rural farming areas. The designed system is seeding and fertilizing agriculture golem victimization microcontroller. The aim of the designed system is to seeding, fertilizing and soil pH, temperature, moisture, wetness checking. The golem is controlled by remote. The designed system involves navigation of golem to the destination with success and will the on top of functions. The direction of the golem is controlled via remote. The golem and also the remote system area unit connected through net system. half dozen DC motors area unit used for navigation of the golem. The speed of the DC motors is controlled victimisation controller. The coil is employed to manage seeding and fertilizing.

Amrita Sneha. A, Abirami.E, Ankita.A, Mrs. R. Praveena, Mrs. R. Srimeena[2]

This paper strives to develop a mechanism capable of playing operations like automatic plowing, seed dispensing, fruit choosing and chemical spraying. It conjointly provides manual management once needed and keeps tabs on the wetness with the assistance of wetness sensors. The main element here is that the AVR At mega microcontroller that supervises the whole method. at first the mechanism tills the whole field and income to plowing, at the same time dispensing seeds aspect by aspect. The device used for navigation is Associate in Nursing supersonic device that incessantly sends information to the microcontroller. On the sphere the mechanism operates on machine-driven mode, however outside the sphere is strictly operated in manual mode. For manual management the mechanism uses the Bluetooth pairing app as management device and helps within the navigation of the mechanism outside the sphere

Swati D. Sambare, S. S. Belsare[3]

In India, close to concerning seventieth individuals square measure dependent upon agriculture. that the agricultural system in Republic of India ought to be advanced to cut back the efforts of farmers. numerous range of operations square measure performed within the agriculture field like seed sowing, weeding, cutting, chemical spraying etc. terribly basic and important operation is seed sowing. however this strategies of seed sowing square measure problematic. The equipment's used for seed sowing square measure terribly troublesome and inconvenient to handle. therefore there's a desire to develop instrumentality which can cut back the efforts of farmers. this method introduces an effect mechanism that aims to drop seeds at specific position with mere distance between 2 seeds and contours whereas sowing. The drawbacks of the prevailing sowing machine are going to be removed with success during this automatic machine.

Vijaykumar N Chalwa1, Shilpa S Gundagi[4]

In this project work AN engineering resolution to the present human health hazards concerned in spraying doubtless venomous chemicals within the confined area of a hot AND

muggy greenhouse or agricultural field is achieved by the planning and construction of an autonomous mobile automaton to be used in cuss management and malady hindrance applications in business greenhouses. For this a mechanical automaton is intended. The effectiveness of this platform is shown by the platforms ability to with success navigate itself down rows of a greenhouse, whereas the chemical spraying system with efficiency covers the plants equally with spray within the set dosages.

3.SYSTEM DESCRIPTION

3.1 Working

The assembly of the robotic system is built using high torque DC motor, RF module (transmitter receiver) for wireless communication, relay driver circuit, Battery package and microcontroller module which is shown in block diagram above. When DC motor is started, the vehicle moves along the particular columns of ploughed land for digging and sowing the seeds and its movement is controlled by remote guiding device. The remote control transmitter and receiver is shown in block diagram.

This system has two main sections, robot end and control section, which are intercommunicated

3.2 component description

1. Frame:

Size: 450mm*300mm*50mm
Material: wooden

2. SEEDER:

Length: 235mm
Diameter: 50mm

3. Digger:

Size: 150mm*80mm

4. Worm gear:

Diameter: 30mm
Material: fiber

5. Tank:

Height: 650mm
Width: 165mm

6. Wheel:

Diameter: 65mm
Material: fiber

7. Motor:

(Total five motors are connected and two motor are dummy motors which is connected to wheel)

- One motor is submersible connected to water tank.
- Two motor (12v dc motor) connected to wheel.
- One is connected to seeder.
- And remaining one is connected plaw.

3.3 software design

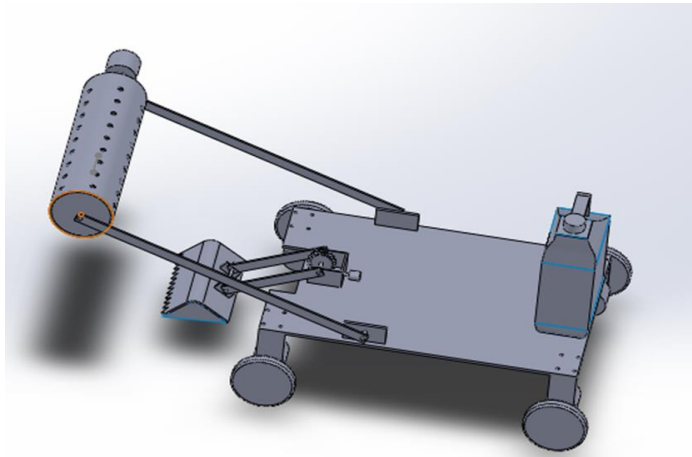

Fig no 1:software design of agri digging and seeding.

Sample papagraph Define abbreviations and acronyms the first time they are used in the text, even after they have been defined in the abstract. Abbreviations such as IEEE, SI, MKS, CGS, sc, dc, and rms do not have to be defined. Do not use abbreviations in the title or heads unless they are unavoidable.

4. ADVANTAGES AND DISADVANTAGES

4.1 Advantages

- 1- It is one of the latest and sophisticated system.
- 2- It control whole system automatically.
- 3- It is reliable and requires less maintenance.
- 4- It is Affordable.
- 5--The system working is simple and easy to use.

4.2 Disadvantages:

- 1-Need DC power supply all time and quickly discharged.
- 2- Need of skilled workers to drive and for maintenance.

4.3. Applications

- 1-The system or robot can be mainly use in agricultural field.
- 2-It is used in home gardening.

- 3-It is used in sports ground
- 4-It is used in fruit gardens.

5. CONCLUSIONS

This project entitled “ AGRICULTURAL ROBOT “has been using discrete electronics component around advance microcontroller 8051 the system is operated by DC motors and corresponding output are obtained means performing agri. operations.The above parameters are sensed and automated by the ultimate application of arduino microcontroller. It gives very precise and accurate results.

In this project we made an effort to overcome some problems in agriculture. The rapid growth in the industries is influencing the labors who are situating in the villages to migrate to the cities. This creating the labor problem for the agriculture. The wages for the labor is also more.

5.ACKNOWLEDGEMENT

I would like to express my gratitude and appreciation to all those who gave me the possibility to complete this report. A special thanks to Prof. Y. R. Ingole(Head of Department, Mechanical) & Prof. C. srinidhi(Seminar Co-ordinator) & Prof. M.V. Mankar(Seminar Co-ordinator) whose help, stimulating suggestions and encouragement, helped me to coordinate my project especially in writing this report.

We would also like to acknowledge with much appreciation the crucial role of the staff of Mechanical department, who gave the permission to use all required machinery and the necessary material to complete the project.

Last but not least, many thanks go to the project guide, Prof. P.V. Bute who have given his full effort in guiding me in achieving the goal as well as his encouragement to maintain our progress in track. I would to appreciate the guidance given by other supervisor as well as the panels especially in our project stage-1 presentation that has improved our presentation skills by their comments.

REFERENCES

[1] Nithin P V, Shivaprakash S (2016), "Multi Purpose Agricultural Robot" International Journal of Engineering Research.

[2] Swati D. Sambhare, S. S. Belsare (2015), "Seed Sowing Using Robotics Technology" International Journal of scientific research and management (IJSRM)

[3] Vijaykumar N Chalwa, Shilpa S Gundagi (2014), "Mechatronics Based Remote Controlled Agricultural Robot" International Journal of Emerging Trends in Engineering Research

[4] Swetha S, Shreeharsha G. H. (2015), "Solar Operated Automatic Seed Sowing Machine" International Journal Of Advanced Agricultural Science and Technology.

[5] P.Usha, V .Maheswari (2016), "Design And Implementation Of Seeding Agricultural Robot" Journal of Innovative Research and Solutions (JIRAS).

[6] Blackmore, B. S., Stout, W., Wang, M., and Runov, B. (2005)." Robotic agriculture – the future of agricultural mechanization?", 5th European Conference on Precision Agriculture. ed. J. Stafford, V. The Netherlands, Wageningen Academic Publishers. Pp.621-628.

[7] Gholap Dipak Dattatraya, More Vaibhav Mhatardev, Lokhande Manojkumar Shrihari (2014), Robotic Agriculture Machine, International Journal Of Innovation Research In Science Engineering and Technology.