

# GENERATION OF HIGH VOLTAGE USING COCKCROFT –WALTON VOLTAGE MULTIPLIER CIRCUIT

Amit Kumar Sinha<sup>1</sup>, Rajeev Kumar<sup>2</sup>

<sup>1</sup>Asst.Professor, Dept.of Electrical Engineering, Axis Institute of Technology & Management, Kanpur.

<sup>2</sup> B.Tech , Student, Electrical Engineering, Axis Institute of Technology & Management, Kanpur.

\*\*\*

**Abstract** - The objective of the project is to design a voltage multiplier which should be able to multiply voltage from an input as low as 12 Volts to a maximum output of approximately 200 Volts. As High Voltage DC (HVDC) transmission is becoming more popular in the present scenario of bulk power transmission over long distance transmission, it is required to study the testing of various insulation materials at laboratory level in under graduate and post graduate course curricam. Since, generation and handling of high voltage is very dangerous and required skilled personnel in the laboratory. In addition, it is very much costly. Cockcroft-Walton multiplier provides suitable high DC voltage source from a low input voltage i.e. 230 V AC supplies which is rectified by using half wave rectifier circuit. Designing of the circuit is based on Cockcroft Walton Principle that consists of ladder network of Capacitor and Diodes. Other specifications considered carefully while designing multiplier and components must be used based on size consideration for expected load current and expected output voltage. Finally, the results are compiled from the simulations done on MATLAB. A prototype was designed and experimental result was tested and demonstrate was purpose.

**Key Words:** HIGH VOLTAGE, DC, VOLTAGE MULTIPLIER CIRCUIT, COCKCROFT-WALTON MULTIPLIER

## 1. INTRODUCTION

In many application, the used of high voltage with low power supply devices are needed in communication, biomedical equipment, high voltage testing and any other field are in high demand. Depending on the application the converted power ranges from some Watts to values above 100kW while output voltages above 1kV up to a few 100kV are needed. The aims of this paper is to design a high voltage low power supply device that can produce high voltage up to 10 kV with lowest current and power values. On top of that, the powers supply device is small in size, simple and low cost. Generation of high DC voltages is mainly required in research work in the areas of pure and applied physics. Sometimes, high direct voltages are needed in insulation tests on cables and capacitors. Impulse generator charging units also required high DC voltages of about 100 to 200 kV. Normally, for the generation of high voltages DC around 100 kV, the output currents are about 10 mA.

Impulse generator charging units require 100 to 200 kV output. Many a times, output of the circuit is expected in a way such that a complete discharge of the capacitor should result in killing of a foreign material (conducting) coming in contact with it (When the output terminals are shorted by the conducting body) as done in case of a Mosquito zapper racket. On the basis of requirements, we have designed our circuit with due consideration to output voltage and current. The design of the complete circuit assembly is as depicted in the following block diagram. The input of the circuit is fed from a 12 Volts AC supply. This supply of 12 Volts can be achieved using two ways- Either by directly using a step down Transformer of rating 230V/12V; by using a 12 Volts DC supply and by connecting an inverter circuit, the output voltage can be obtained.

## 2. COCKCROFT-WALTON MULTIPLIER

Cockcroft Walton Voltage Multiplier is very well developed high voltage generation technique and can be used at laboratory level. It is clear that Van-De-Graf Generator needs a large space while Grienacher Voltage doubler is not suited to handle voltage level more than 10kV. The Cockcroft-Walton is a voltage multiplier that converts AC or pulsing DC electrical power from a low voltage level to a higher DC voltage level. It is made up of a voltage multiplier ladder network of capacitors and diodes to generate high voltages. Unlike transformers, this method eliminates the requirement for the heavy core and the bulk of insulation/potting required. Using only capacitors and diode in cascading network these voltage multipliers can step up relatively low voltages to extremely high values, while at the same time being far lighter and cheaper than transformers. The main disadvantages of CWVM are the delay between input and output, large output voltage ripple, voltage drop and non-negligible amount of capacitance needed.

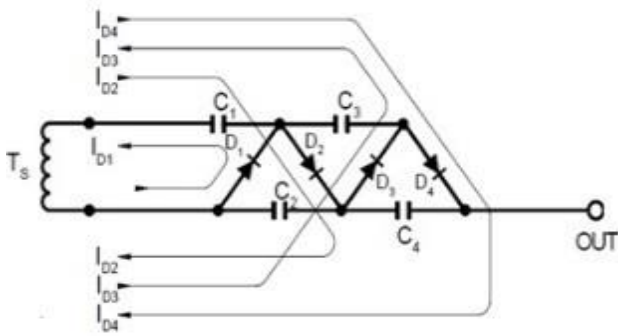

Fig -1: Cockcroft-Walton multiplier

Where,  $C_1, C_2, C_3, \dots, C_n =$  Capacitor  $D_1, D_2, D_3, \dots, D_n =$  Diode, And  $ID_1, ID_2, ID_3, \dots, ID_n =$  Diode Current. The advantages of Cockcroft-Walton Multiplier circuit are low in cost, small in size and can be easy to insulate the circuit. Another advantage of voltage of multiplier circuit is its peak to peak voltage at each stage will be double.

Consider operation of two stages Cockcroft-Walton multiplier is shown in figure1.

- 1) When  $T_s$  is negative, then Capacitor  $C_1$  charges through Diode  $D_1$  to  $V_{max}$ .
- 2) When  $T_s$  is positive, then  $V_{max}$  add arithmetically existing potential  $C_1$ , thus  $C_2$  charges to  $2V_{max}$  through Diode  $D_2$ .
- 3) Again  $T_s$  is negative,  $C_3$  charge  $2V_{max}$  through Diode  $D_3$ .
- 4) Again  $T_s$  is positive, Capacitor  $C_4$  charge Diode  $D_4$  to  $4V_{max}$ .

Therefore output of multiplier =  $V_{max} * N$

Where,

$N =$  Number of stages.

Designing of Multiplier circuit most commonly half wave circuits are used. And because of the multiplier circuit, high voltage develops at the output side of the Cockcroft-Walton multiplier circuit.

Design of Cockcroft voltage multiplier is simple Careful consideration of all component parameters is the only way to insure both reliable and predictable circuit performance.

### 3. Design of Cockcroft-Walton Multiplier Circuit

This circuit is consisting of series parallel combination of diode to achieve the blocking voltage as required. Also, the rating of capacitor is matched to withstand the voltage level in a each stage. Cockcroft-Walton multiplier has different construction. In this paper half wave "Cockcroft-Walton" multiplier is shown.

$$2\delta V = q \sum_{n=2}^{2n} \frac{1}{C_n} \quad (1)$$

$$q = IT \quad (2)$$

$$q = I/f \quad (3)$$

$\delta V$  is amount of ripple generated by the system, since it passes through  $C_2, C_4, C_6, \dots$  only because these capacitor columns is known as *smoothing column* as voltages through these circuit remain constant. Whilst the voltage through  $C_1, C_3, C_5, \dots$  oscillates in same manner as supply varies that is the reason it is known as *oscillating column*. „q“ is amount of charge injected to smoothing circuit. For n stage total ripple is given by:

$$2\delta V = q \left( \frac{1}{C_{2n}} + \frac{2}{C_{2n-2}} + \frac{3}{C_{2n-4}} + \frac{4}{C_{2n-6}} \dots + \frac{n}{C_2} \right) \quad (4)$$

From above it is clear that the voltage ripple generally depend on the lowest capacitor hence size of capacitor at lowest end can be kept smaller. However, due to loading effect and other un-avoidable condition this may create a severe damage to the system hence it is advisable to keep this value identical.

$$C_{2n} = C_{2n-2} = C_{2n-4} = C_{2n-6} = \dots = C_2 = C$$

As putting the above identical values equation (4) can be written as

$$\delta V = \frac{1}{2fC} \left( \frac{n(n+1)}{2} \right) = \frac{1}{fC} \left( \frac{n(n+1)}{4} \right) \quad (5)$$

It is very much obvious from the equation (5) that the voltage ripple is constant and depends on the number of stage. As number of stages increases the ripple content is increases proportional to  $n(n+1)$ . Variation of ripple with number of stage is given in figure 4. As it is clear that the variation is non-linear after  $n=10$  and  $n=11$  stages, still it is comparable that till lower stages and ripple can be linearised.

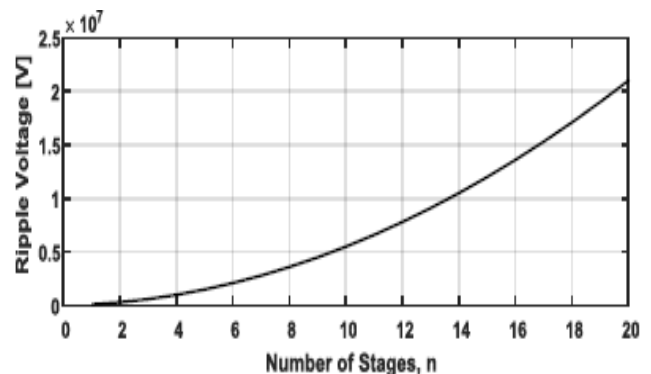

Fig 2. Variation of Ripple Voltage with number of stages in Cockcroft Walton.

In addition, ripple is function of number of stages and number switching frequency for a fixed capacitor design. Hence, varying frequency ripple can be reduced and can be treated as high frequency switching. In the present work, diode drop is neglected for the sake of simplicity and to reduce the complexity of the circuit equations. Also, parasitic effect of diode and capacitor is neglected as its contribution is very small. There are two modes of

operation of CWVM viz. no load operation, and operation under loaded condition. When load is applied there will be some drop due to internal behavior and load applied. That drop is considerably high and reduces the output voltage in a great manner.

Total drop  $\Delta V$  is given by:

$$\Delta V = \Delta V_n + \Delta V_{n-1} + \Delta V_{n-2} + \dots + \Delta V_1$$

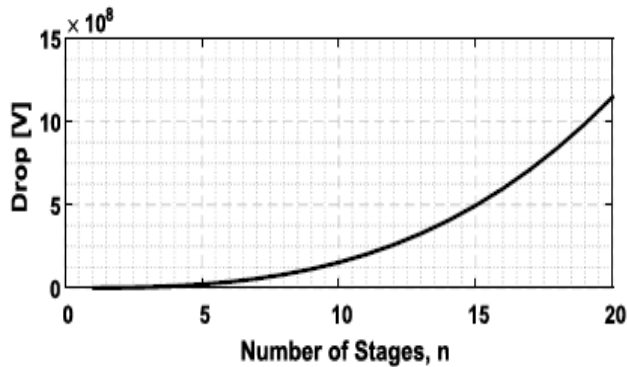

Fig. 3 Variation of Drop Voltage for a fixed frequency

As to get a fixed stage of output voltage with constant frequency and capacitor value, optimal number of stage can be calculated. Again, this equation number is considered when number of stages is assumed.

Table I Parameter Value for Simulation

Parameter	Numerical Value [unit SI]
Input Voltage to Primary of X'mer $V_p$	230[V]
Secondary Voltage	10000 [V]
Supply Frequency, f	50 [Hz]
Capacitor, C	100 [nF]
Number of Stages, n	7

Table 1. Parameter Value for Simulation.

#### 4. SIMULATION AND RESULTS

With values given in table I, one can simulate this model with a fixed rating of all elements. Voltage drop through diode is neglected.

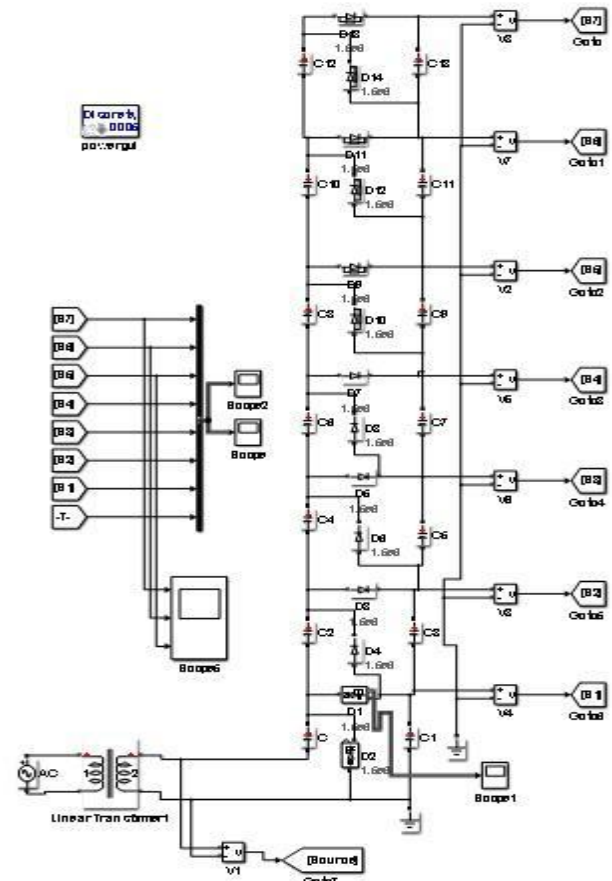

Fig. 4 Circuit Arrangements in Simulation

Fig. 6 shows the simulation arrangement in this figure scopes are the virtual oscilloscope where the visualization of voltages are taken. It can be used as recording purpose also.

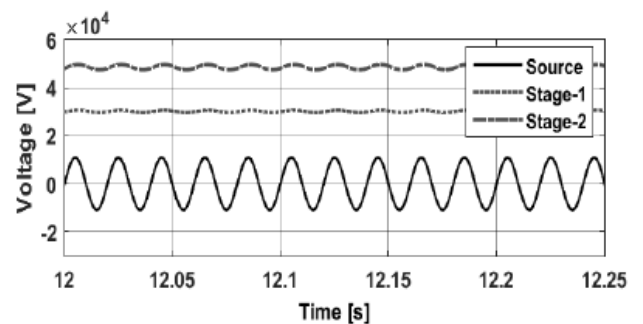

Fig. 5 Voltages of Source and Stage-1, 2

Simulation shown in Fig 4 is simulated in MATLAB environment for various numbers of runs and with 20 seconds run till the stable output is not achieved. After proper stable condition Fig. 7 is plotted for the stage output of stages 5, 6, & 7.

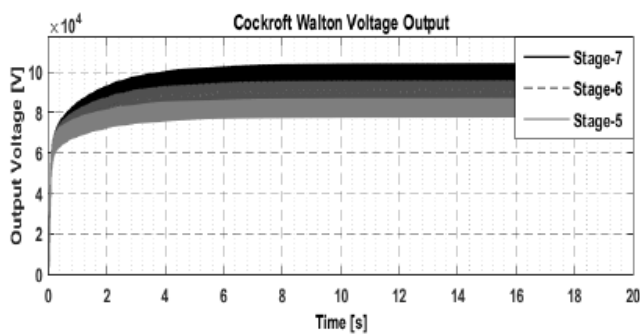

Fig. 6 Output of Final Three Stages

The darkest waveform is stage 7 output with 100kV output level and some ripple content. Ripple content in final stage is high comparable to lower stage because as discussed in previous section voltage double not only doubles the maximum voltage it also doubles the ripple content. It is very difficult to estimate the ripple content in the actual hardware circuit. But the amount of ripple can be observed in Fig 10 for the stage-5, stage-6 and stage-7.

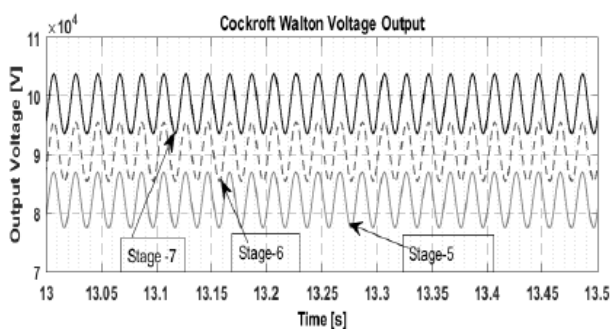

Fig. 7 Ripple Voltage Level of Output Stages

5. CONCLUSION

In this paper we accomplished a simulation waveform and analytical generation of high voltage for the laboratory purpose. Generation of High Voltage at laboratory up-to 100kV is designed and simulated for laboratory level. In future this work can be modeled with all non idealities and derivative effect of capacitor. There for size of the complete high voltage circuit is small and cost is also less. This small size circuit gives high voltage at the end of multiplier circuit. Because of the light weighted circuit it is portable it gives high reliability. Construction of whole circuit is simple and robust in nature. This multiplier circuit is useful for a scientific instrument, TV sets and CRTs, Oscilloscope, x-ray and photomultiplier tubes and field testing of HV cables.

REFERENCES

[1] High Voltage Generation by using Cockcroft-Walton Multiplier," International Journal of Science, Engineering and Technology Research (IJSETR), Volume 4, Issue 2, February 2015, vol. 4, no. 2, pp. 256-259, February 2015

[2] Waluyo, Syahrial, Sigit Nugraha3, And Yudhi Permana, "Miniature Prototype Design And Implementation Of Modified Multiplier Circuit Dc High Voltage Generator," International Journal of Electrical Engineering and Technology (IJEET), vol. 6, no. 1, pp. 01-12, January 2015.

[3]. C. K. Dwivedi ,M. B. Daigavane," Multi-purpose low cost DC high voltage generator (60 kV output), using Cockcroft-Walton voltage multiplier circuit, International Journal of Science and Technology Education Research Vol. 2(7), pp. 109 - 119, July 2011.

[4] G.S. Senthil Raaj, G.T. Sundar Rajan," Simulation and Implementation of Single-Phase Single-Stage High Step-Up AC-DC Matrix Converter based of Cockcroft-Walton Voltage Multiplier, International Conference on Innovations In Intelligent Instrumentation, Optimization And Signal Processing "ICIIOSP-2013"

[5] Cheeru G. suresh, Elizabethh Rajan,Chittesh V.C.,Chinnu G. suresh," Transformless high step-up DC-DC Cockcroft-Walton multiplier in hybrid system, IRF International Conference on 10th August 2014, Cochin, India, ISBN: 978-93-84209-43-8

[6] Adinath Jain, Simith E," AC-DC Matrix Converter Based On Cockcroft-Walton Voltage Multiplier, IOSR Journal of Engineering (IOSRJEN), Vol. 04, Issue 07 (July. 2014). PP 16-23

[7] Naidu MS, Kamaraju V (2004),||High Voltage Engineering, Third Edn. McGraw- Hill Company Ltd. pp. 146-156

[8] C. L. Wadhwa, –High Voltage Engineering.New Age International Publication. pp. 56-63.

BIOGRAPHIES



**Amit Kumar Sinha** was born in Jamshedpur (Jharkhand), India, in 1991. Currently, He is working as Asst.Professor in Axis Institute of Technology and Management, Kanpur. He received B.E (Electrical and Electronics) and M.E (Power Electronics and Drives) from Anna University, Chennai. His area of interest includes Control System, Power Electronics, Electrical Machines and Power Quality.



**Rajeev Kumar** was born in Madhubani (Bihar), India, in 1996. He is doing B.tech (Electrical Engineering) from Axis Institute of Technology and Management, Kanpur. His area of interest includes Power Electronics, Electrical Machines and Power System. He is a student member of Institute of Electrical and Electronics Engineers (IEEE).