

OVERVIEW OF DESIGN AND INTEGRATION OF UNMANNED AERIAL VEHICLE AIRCRAFT FOR SURVEILLANCE (DEFENSE APPLICATIONS)

L.Subhashree¹, T. Kousalya², T.Aruna³, G. Tony Santhosh⁴

^{1,2,3.} UG Scholar, Department of Electronics and Communication Engineering, Alpha College of Engineering, Chennai, Tamilnadu, India.

^{4.} Assistant Professor, Department of Electronics & Communication Engineering, Alpha College of Engineering, Chennai, Tamilnadu, India

Abstract: *Unmanned Aerial Vehicles (UAVs), Micro UAVs and Grounded UAVs are gained a lot of popularity during the last few years. The use of these vehicles has grown drastically to operate in dangerous situations where human can be safe at a distance. Unmanned Aerial Vehicle Systems (UAVs) is an emerging technology with a tremendous potential to revolutionize warfare and to enable new civilian applications. UAVs are mainly used for intelligence, surveillance and reconnaissance (ISR), border security, counter insurgency, attack and strike, target identification and designation, communications relay, electronic attack, law enforcement and security applications, environmental monitoring and agriculture, remote sensing, aerial mapping and meteorology. UAVs are better suited for dull, dirty, or dangerous missions than manned aircraft. Although armed forces around the world continue to strongly invest in researching and developing technologies with the potential to advance the capabilities of UAV Systems. In this paper address the Integration of simple UAV for defense applications using the hardware and software*

advantage that they can sense image at long distances. One disadvantage though is that it takes sufficient time to react as turning a fixed-wing vehicle takes time and space until the vehicle regains its course. The rotary-wing vehicles are also known as Vertical Takeoff and Landing (VTOL) vehicles. They have the advantage of minimum launching time, as well as they don't need enough space for landing. They have high maneuverability and hovering. Rotary wing vehicles have short range radars and cameras to detect traffic movement. The drawback of such type of vehicles is that the rotary motion leads to vibration. systems presented and discussed during the UAV 2003 workshop UAVs have different payload weight carrying capability, their accommodation (volume, environment), their mission profile (altitude, range, duration), and their command, control and data acquisition capabilities vary significantly. A summary of the UAV capabilities and characteristics were presented in [2] as shown in the Table 1. The smallest vehicles are Micro UAVs (MAVs) like the AV Black Widow developed for military surveillance, law enforcement, and civilian rescue efforts.

Keywords—UAVs, MUAUV, GUAUV, ISR, reconnaissance

I.INTRODUCTION

UAVs are semi-autonomous or fully autonomous aircrafts that can carry cameras, sensors, communication equipment or other payloads. UAVs have been a topic of research for military applications since 1950s. UAVs were used as prototypes in World War I and II. In the last decade, Defense Advanced Research Projects Agency (DARPA) initiated several projects to increase use of UAVs in military applications [1]. Lately, increasing interest has been found in diverse civilian, federal and commercial applications, such as traffic monitoring.

UAVs are classified as either rotary-wing or fixed-wing. Fixed-wing vehicles are simple to control, have better endurance, and are well suited for wide-area surveillance and tracking applications. Fixed wing vehicles have another

Vehicle	Endurance (hours)	Payload Weight(kg)	Altitude Capacity (ft)
Aerosonde	40	1	20,000
Altus2	24	150	65,000
AV Black Widow	5	0	1,000
AV Dragoneye	1	0.5	3,000
AV Pointer	1.5	0.9	3,000
AV Puma	4	0.9	3,000
AV Raven	1.25	0.2	3,000
BQM-34	1.25	214	60,000
Chiron	8	318	19,000
Darkstar	8	455	45,000
Exdrone	2.5	11	10,000
Global Hawk	42	891	65,000
Gnat750	48	64	25,000
Helios	17+		97,000
MLB Bat	6	1.8	9,000

MLB Volcano	10	9	9,000
Pathfinder	16	40	70,000
Pioneer	5.5	34	12,000
RMAX	1	28	500
Predator	29	318	40,000+
Shadow200	4	23	15,000
Shadow 600	14	45	17,000

Table 1: Capabilities and characteristics of UAV

Larger than MAVs are Small UAVs (SUAVs) like the MLB Bat. SUAVs are largely used for traffic surveillance oriented research as they are designed for small regional scales and carry a payload of a few kilograms. They are portable, flexible and autonomous in their applications. Medium altitude and medium endurance UAVs (MUAVs) are used for regional scale observations. They can be used for applications such as mapping and monitoring of fire hazards, weather phenomena etc. UAVs that operate in High Altitude with Long Endurance (HALE) range, like the Helios, are used for applications such as mapping, communication, and monitoring tasks of the earth surface and the atmosphere, as they can work at altitudes up to 100,000 feet.

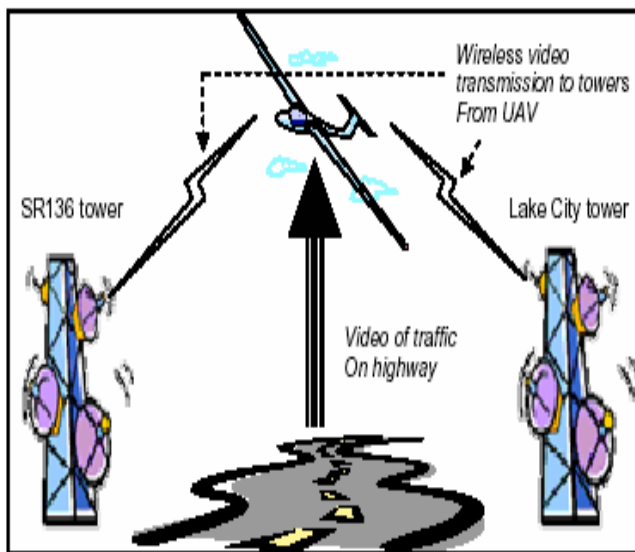

The Federal Aviation Administration (FAA) defines a UAV as an unmanned aircraft or “device that is used or intended to be used for flight in the air that has no onboard pilot. This includes all classes of airplanes, helicopters, airships, and translational lift aircraft that have no onboard pilot. Unmanned aircraft are known by a host of names including remotely piloted vehicles (RPVs), drones, robot planes, and unmanned combat aerial vehicles, but do not include missiles and rockets. UAVs serve myriad military missions, have commercial and civilian applications, and possess capabilities that are as varied as their designs. Military uses include national defense, disaster response, homeland

security and law enforcement, remote sensing, and “ISR” missions (intelligence, surveillance, and reconnaissance). Civilian applications include traffic surveillance, weather monitoring, communications relay, border management, maritime patrol, crime prevention, forest fire monitoring, and drug interdiction. Similarly, in the commercial sector, UAVs can undertake tasks relating to fishery and agricultural management, freight, pipeline monitoring, aerial photography, and search and rescue. In doing so, UAVs optimize the political, business, and human costs of “dull, dirty, and dangerous” activities.

UAVs are dynamic. They are nano, micro, mini, short-range, and tactical medium- and high-altitude combat aircraft whose diverse platforms complement a functional versatility. They are manufactured in all shapes and sizes, from hand-held devices that weigh a mere few ounces to the several-thousand pound hunter-killer machines like the Predator B and Northrop-Grumman Global Hawk. In terms of performance, UAVs can be indefatigable relative to manned operations. For example, the hand launched Qinetiq Zephyr solar-powered UAV can lift a small communications payload above 40,000 feet and stay aloft for two weeks. Some UAVs are even entirely autonomous. The U.S. Air Force is training more unmanned aircraft pilots than on-board pilots. While the path for UAV development in the military, civil, and commercial sectors domestically and internationally seems clear, the saying that “the sky’s the limit” may literally be true as UAVs increasingly become part of the national airspace system (NAS). They may be controlled either manually or through an autopilot using a data link to connect the pilot to the aircraft. They range in size from wingspans of six inches to 246 feet; and can weigh from approximately four ounces to over 25,600 pounds. In the United States alone, approximately 50 companies, universities, and government organizations are developing and producing some 155 unmanned aircraft designs. Regulatory standards need to be developed to enable current technology for unmanned aircraft.

II. UNMANNED AERIAL VEHICLE (UAV) AIRCRAFT SYSTEM OVERVIEW

UAVs are a component of an unmanned aircraft system (UAS); which include a UAV, a ground-based controller, and a system of communications between the two. The flight of UAVs may operate with various degrees of autonomy: either under remote control by a human operator or autonomously by onboard computers. This UAV system has consists of three modules namely

- A. Transmitter (UAV)
- B. Receiver (GCS)
- C. Data Processing (Front end software)

A. TRANSMITTER

Transmitter module consists of the following important components

1. Power supply
2. Auto Pilot
3. ESC
4. Propellers
5. 3Phase Brushless Motor
6. GPS Receiver
7. RF Modem
8. Servo Expansion Board
9. Video Camera
10. Video Transmitter



LiPo batteries can be found in packs of everything from a single cell (3.7V) to over 10 cells (37V). The cells are usually connected in series, making the voltage higher but giving the same amount of amp-hours. The 3SP1 batteries which means 3 cells connected in series as 1 parallel (just forget the parallel, as it has no sense because we just use 3 cells in series). This should give us 11.1V but at fully charged it actually gives us around 12V instead.

For a brushless motor with a Kv-rating of 1000, this gives us a maximum of 12000 rounds per minute. This number is totally fictive as the battery voltage will drop immediately to around 11.1V (at fully charged state) when current is being drained. Anyways, this gives us a good idea about how fast the propellers will be spinning. As for the battery capacity regards you should make some calculations on how much power your motors will draw and then decide how long flight time you want and how much influence the battery weight should have on the total weight. A good rule of thumb is that you with four EPP1045 propellers and four Kv=1000 rated motor will get the number of minutes of full throttle flight time as the same number of amp-hours in your battery capacity. This means that if you have a 4000mAh battery, you will get around 4 minutes of full throttle flight time – though with a 1KG total weight you will get around 16 minutes of hover.

Another thing to be-aware of when selecting the right battery is the discharge rate, formerly known as the C-value. The C-value together with the battery capacity indicates how much current you are able to source from the battery. The calculations follow this simple rule: Max Source = Discharge Rate x Capacity

2. Autopilot

An autopilot is often an integral component of a Flight Management System. Modern autopilots use computer software to control the aircraft. The software reads the aircraft's current position, and then controls a flight control system to guide the aircraft. Alternately defined autopilot system is a mechanical, electrical, or hydraulic system used to guide a vehicle without assistance from a human being. It can make the plane automatically fly according to certain attitude, course, altitude. It consists of a sensor, a computer and a servo mechanism. When a

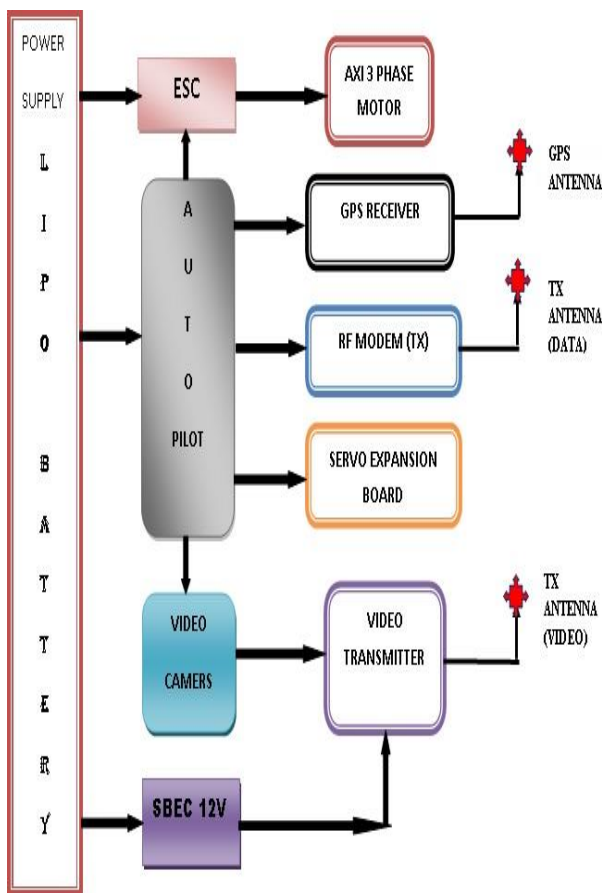

1. Power Supply

All this leads to the battery, the power source for the whole device. For the battery two types can be used, where of one of them is highly recommended. The NiMH and the LiPo. as they first and foremost are not able to provide enough current and secondly they weight a lot more than LiPo batteries when they have the necessary current ratings. Instead we should talk about LiPo batteries, but in this world there are also a lot of different variants of these too.

disturbance accrued to the plane deviated from the original posture, the sensitive element (for example, the gyroscope) will detect the change of attitude; the Computer calculate the rudder deviator; the Servo (or called the rudder) will correct it. The autopilot system and plane form a feedback circuit to ensure the stable flight.

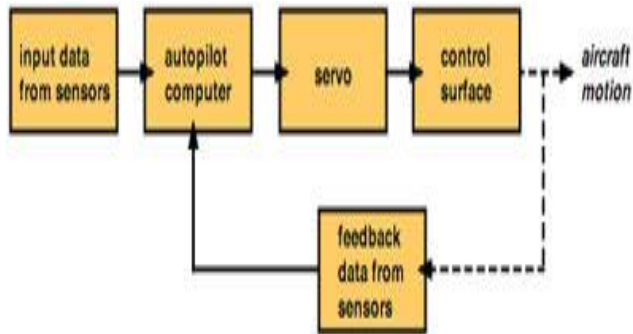

- Input voltage 12v DC
- Operating power (no modem) 800mW
- Operating power (With modem) 1200mW
-

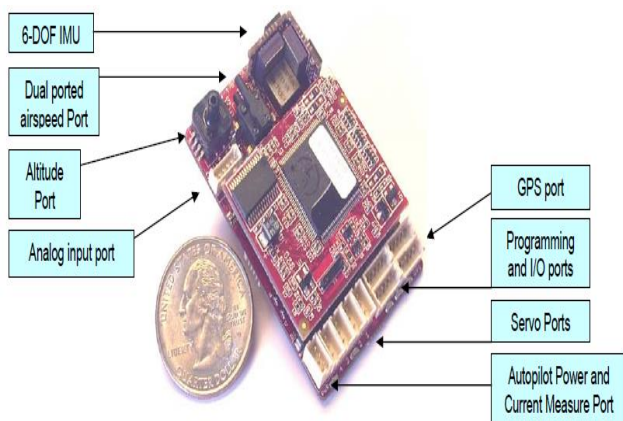

3. Electronic Speed Controller

As the brushless motors are multi-phased, normally 3 phases, you can't just apply power to it to make it spin. The motors requires some special phase-control electronics that is capable of generating three high frequency signals with different but controllable phases, but the electronics should also be able to source a lot of current as the motors can be very "power-hungry". In this case we got the Electronic Speed Controllers, known as ESC's. The ESCs is simply a brushless motor controller board with battery input and a three phase output for the motors



For the control it is usually just a simple PPM signal (similar to PWM) that ranges from 1ms (min speed=turn off) to 2ms (max speed) in pulse width. The frequency of the signals does also vary a lot from controller to controller, but for a UAV it is recommended to get a controller that supports at least 200Hz or even better 300Hz PPM signal, as it should be possible to change the motor speeds very quickly to adjust the UAV to the stable position. It is also possible to get ESCs that is controlled thru One Wire or I2C. These tends to be much more expensive though, but sometimes it is also possible to "mod" other ESCs to add the I2C feature

4. Propellers

A Propeller "Lifts" an Airplane Forward. Think of a propeller as a spinning wing. Like a wing, it produces lift, but in a forward direction—a force we refer to as thrust. Its rotary motion through the air creates a difference in air pressure between the front and back surfaces of its blades. Other words A propeller is a type of fan that transmits power by converting rotational motion into thrust. A pressure difference is produced between the forward and rear surfaces of the airfoil-shaped blade, and a fluid (such as air or water) is accelerated behind the blade. Combine this with any forward speed the propeller may have, the relative airflow is also different from the hub to the tips. To keep thrust equal along the blade, they have a build in twist. The design is such that the blade is thick at the hub with a large blade angle and thin at the tip with a low blade angle.



5. Brushless Motor

UAV have motors with a propeller. Most of the times the so called Brushless Motors are used to drive the propellers. Brushless motors are a bit similar to normal DC motors in the way that coils and magnets are used to drive the shaft. Though the brushless motors do not have a brush on the shaft which takes care of switching the power direction in the coils, and this is why they are called brushless. Instead the brushless motors have three coils on the inner (center) of the motor, which is fixed to the mounting. On the outer side it contains a number of magnets mounted to a cylinder that is attached to the rotating shaft. So the coils are fixed which means wires can go directly to them and there for there is no need for a brush.

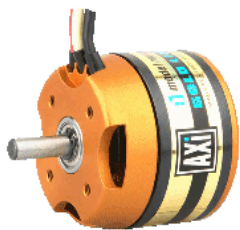

Brushless motor

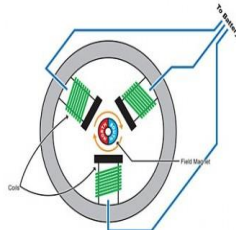

Brushless motor internal

The reason why we use brushless motors instead of normal DC motors is the much higher speeds and less power usage for the same speed. The brushless motors are more efficient as there is no power lost as there is in the brush-transition on the DC motors

6. GPS Receiver

A GPS navigation device, GPS receiver, or simply GPS is a device that is capable of receiving information from GPS satellites and then to calculate the device's geographical position. Using suitable software, the device may display the position on a map, and it may offer directions. The Global Positioning System (GPS) uses a global navigation satellite system (GNSS) made up of a network of a minimum of 24, but currently 30, satellites placed into orbit A GPS device can retrieve from the GPS system location and time information in all weather conditions, anywhere on or near the Earth. A GPS reception requires an unobstructed line of sight to four or more GPS satellites



7. RF Modem

Radio modems transfer data wirelessly across a range of up to tens of kilometers. Using radio modems is a modern way to create Private Radio Networks (PRN). Private radio networks are used in critical industrial applications, when real-time data communication is needed. Radio modems enable user to be independent of telecommunication or satellite network operators. In most cases users use licensed frequencies either in the UHF or VHF bands. In certain areas licensed frequencies may be reserved for a given user, thus ensuring that there is less likelihood of radio interference from other RF transmitters.



Specifications:

1. Frequency 902-928MHz
2. Input voltage 3.3v
3. Output power 500mW
4. Data rate 115.200Kbps
5. Range 11km (dipole antenna)
6. RX sensitivity -100dBm
7. FHSS Spread spectrum
8. 2dBi dipole antenna

8. Servo Expansion Board

The Servo Expansion has a micro-controller (MCU) that can be programmed to generate Pulse-Width Modulated (PWM) signals. It has 16 connectors for PWM devices. It was designed with servo motors in mind, they can be plugged in right out of the box This expansion is ideal for building anything that uses servos: robotic arms, walking spiders, etc, or anything that uses PWM in general like LED lights.

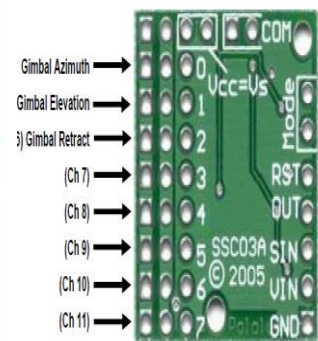

Figure 1 - Port Mapping

Specifications:

- Used for Gimbal azimuth, Gimbal elevation , Gimbal retract
- 8 Channel
- Current consumption 5mA
- Pulse rate 50Hz
- Light weight 2.9 g



9. Video Camera

To make pictures and video look like a professional you can add a Camera Gimbal to your Aerial Video and Aerial Photography Drone for camera stabilization. These come in different formats to suit either an Action Camera or DSRL Style cam

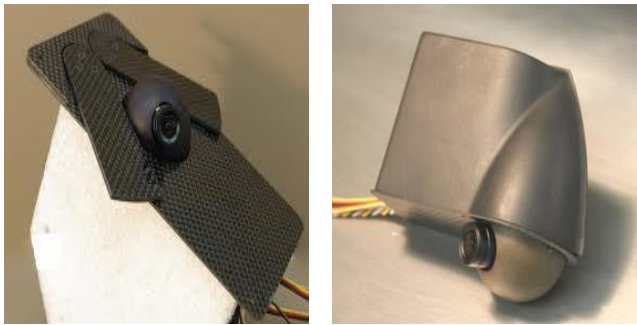

Specification:

- The BTC-40 – 40mm Ball Turret Camera features a rigid and ultra light composite chassis coupled with a novel movement that keeps inertia low and results in fast and smooth action.
- 6-12V DC
- Maximum 2.1 watts

10. Video Transmitter

Video transmitters are designed for secure, high quality video transmission in multipath environments such as metropolitan areas . A high efficiency transmitter design with 100 mWatts RF output power and features such as full frequency band channelization, MPEG2 or MPEG4 video encoding, DVB-T or narrow or ultra-narrow bandwidth settings, QPSK or 16QAM or 64QAM modulation, stereo audio, auxiliary data channel, and variable power output. Transmitters are designed to withstand harsh environments and are ideal for Drones, UAS, UAV, UGV, military, and other applications requiring high quality video transmission in a compact, rugged package.

Specifications:

- Frequency 1.3GHz
- Input voltage 12v DC
- Output power 300mW
- Power consumption 120mA
- Channel 4
- FM Modulation
- Vertical polarization
- RCA Adapter cable

B. RECEIVER/GROUND CONTROL STATION

I found that a conventional laptop computer is fragile for use in the field and decided to create my own ruggedized PC that would be suitable for use in the field and the workshop. Having upgraded my desktop, I have a spare socket AM3 motherboard. The motherboard has an integral video adapter, so will not require a bulky graphics card. To power the PC, I will use a 12 volt ATX power supply. A 19" Samsung LED LCD will be used. The screen comes with a 14.2V mains power supply, this is more than the intended 12v input. I attempted to power the screen with 12V but it would not switch on. To ensure the the LCD will have a consistent 14.2V input, I will use a buck-boost regulator. This means the PC will be able to take a wide input range from 10-20V. The case is constructed from sheet aluminum and 1" aluminum equal angle and held together using M4 stainless-steel cap headed bolts. I think it should be up to the job when it's finished.



UAV Receiver module contains

- I. Video Receiver with Antenna
- II. COMM BOX (Main Board, RF Modem) with Antenna

- III. RC Transmitter
- IV. LAPTOP with Virtual aircraft software
- V. Spectrum Analyser

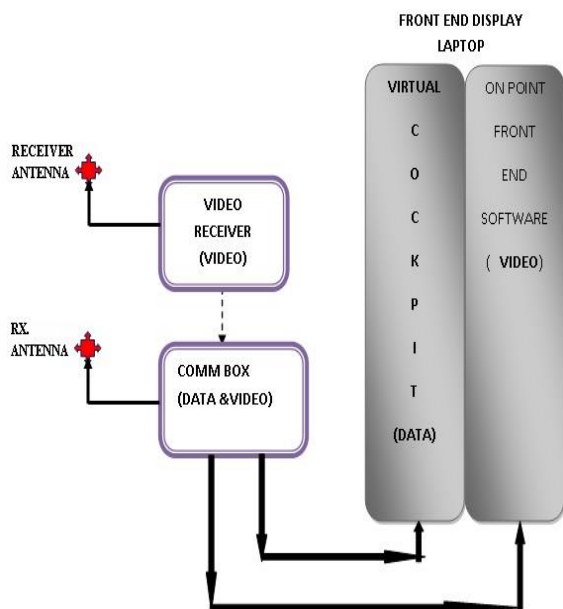

i. Video Receiver with Antenna

The range of the wireless video link is limited by a number of factors. The path loss itself will diminish the signal when distance increases, and obstacles in the line of sight can give additional attenuation. However in a natural environment there are some less obvious challenges to the radio-link that require clever solutions. We will take an in-depth look at the two main issues. Interference and Multipath fading due to reflection. If the interfering signals occur in the same frequency band as the wireless video link it will act as inband noise. This will reduce the signal to noise ratio, resulting in a noisy video image and limited range of the link Even with a strong, noise free signal, a radio link can get sudden dropouts, especially in cluttered or urban environments. This can be due to the reflected propagation path cancelling the direct propagation path. The cancelling occurs because of the phase shift associated with different propagation delay.

Frequency 1.3GHz Input voltage 12V DC



ii. Communication Box with Antenna

Data received from transmitter and display through the GUI based front end software applications. RC transmitter link for direct control for primary flights. Wireless modems like Maxstream 9Xtend, freewaveMM2, Aerocomm, AC4868, AC2248.GPS supports UTC time with pulse synchronization for millisecond accuracy. UTC time stamping for telemetry. Ground station position reference. Video overlay of UAV state information of latitude, longitude, altitude, airspeed, battery voltage, UTC date &time etc..un interrupt able power supply (UPS)charges internal battery over two hour operation using internal battery. Small rugged metal case.



Figure 3 - Antenna Side Ports

iii. RC Transmitter and Receiver

The R/C pilot controls the model by a radio link, which means by using electromagnetic radiation. Basically the R/C equipment consists of a Transmitter operated by the pilot and the airborne units consisting in a Receiver together with one or more Servos depending on the number of channels used and a Battery pack. Mode 1-4 selectable, 127segment, 40*40 LCD, digital transmission memory is used. End point adjustment (EPA), sub trims & servo reversing, dual rates & exponential (ail/ele/rud) fail safe (all-channels; in S-FHSS mode only)throttle cut, trainer system(cord required),throttle position, mix & low battery warnings. Up/down & model timer, it range check mode. R2000GS S-FHSS receiver.



iv. Spectrum Analyzer

Checking frequency interference between data transmission and video transmission.

- Its frequency range is 100MHz to 4GHz,
- Amplitude is 90dBm to 0 dBm(typ),
- lower sample time is 100ms,
- Resolution is 100kHz to 50MHz.
- Units are dBm, dBuV, V/m, A/m, W/m² (dBuV/m,W/cm²etc..via PCsoftware).
- The detectors is RMS and pulse. The input give it to be 500hms SMA Rf input(f).accuracy is +/- 3dB (typ).
- Interface is USB 2.0/1.1.
- Dimensions (L/W/D) are 250*86*27mm weight was 420gr.



C. DATA PROCESSING MODULE

- GUI Based front end software
- Data Analyze – OFF LINE
- Rally point fixing for particular area
- Track the Object/Moving object
- Plot the graph for various data

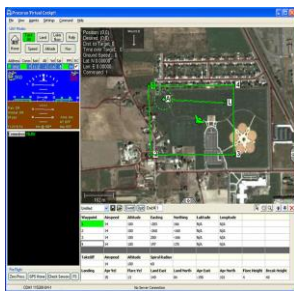

Virtual cockpit main screen

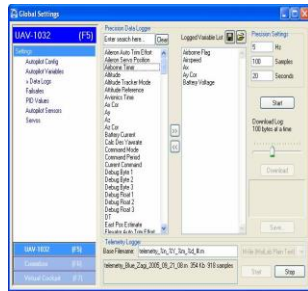

On board data logging

Defense Applications

- Security - Battlefield Management
- Search and Rescue - All Terrain Search and Rescue
- Monitoring - Pollution Control and Air Sampling
- Impact and Disaster Management - Disaster Damage Estimation
- Communications - Secure Telecommunications
- Military weapons
 - Air to Ground Missiles
 - Guided Shells
 - Anti-Tank Missiles
 - Air to Air Missiles

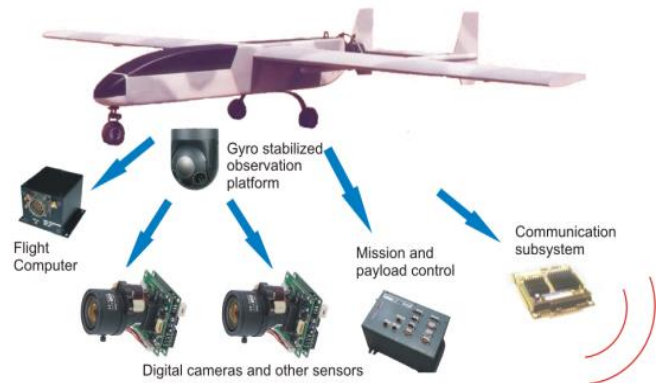

CONCLUSION

Many of the constraints associated with manned aircraft, many developers of UAVs are at liberty to apply new ideas and experiment with unusual, often cutting edge technologies. Advances brought on by UAVs will spawn and facilitate the advent of novel communication architectures, collision avoidance systems, information sharing networks, alternative fuels, and autonomous controls. Many of these advances will likely have an impact on manned aircraft, such as improving cockpit and air traffic automation and by creating an environment conducive to automated traffic separation. These changes, if adequately encouraged and managed, will help in dealing with the mounting complexity of air traffic system. This way we can integrate the UAV for surveillance for many applications.

ACKNOWLEDGEMENT

We are highly indebted to our beloved Principal and HOD of Alpha College of Engineering, for their guidance and constant supervision as well as for providing necessary information regarding this paper. We would like to express our gratitude towards our parents for their kind co-operation and encouragement which help us to completion of this paper We would like to express our special gratitude and thanks to our management for supporting all the way to complete this paper successfully. I would like to extend my sincere thanks to all of them.

REFERENCES

[1]. Srinivasan, S., and Latchman H, "Airborne Traffic Surveillance Systems – Video Surveillance of Highway Traffic", submitted to *ACM 2nd International Workshop on Video*

[2]. Surveillance & Sensor Networks. (http://www.list.ufl.edu/publications/atss_acm_04.pdf)

[3]. Brecher, A., Noronha, V., and Herold, M., "UAV2003- A Roadmap for Deploying Unmanned Aerial Vehicles (UAVs) in Transportation", US DOT/RSPA: Volpe Center and NCRST

Infrastructure, Specialist Workshop, Santa Barbara, December 2003. (<http://www.ncgia.ucsb.edu/ncrst/meetings/20031202SBAUAV2003/Findings/UAV2003-Findings-Final.pdf>)

[4]. <http://www.uavforge.net/>

[5]. <http://diydrone.com/>

[6]. <http://www.helikraftchicopters.com/store/1909/futaba/6ex-2-4g-airp-heli-radio-set-no-servo-with-r617fs-6ex-ss.html> (picture of RC controller)

[7]. http://dlnmh9ip6v2uc.cloudfront.net/images/products/10061-01b_i_ma.jpg

[8]. <http://www.digi.com/products/wireless-wired-embedded-solutions/zigbee-rf-modules/point-multipoint-rfmodules/xbee-pro-xsc#overview>

[9]. <http://www.iflyrc.com.au/images/xbee%20900.jpg>

[10]. <http://www.onlineethics.org>

[11]. <http://www.gaasi.com/products/aircraft/predator.php>

[12]. <http://www.sciencedaily.com/releases/2011/07/110701203725.htm>

[13]. Jonathan Chesebro , –Unmanned Aircraft Systems (UAS)||. [14] Piotr Rudol, –Increasing Autonomy of Unmanned Aircraft Systems Through the Use of Imaging Sensors||, Department of Computer and Information Science Link, opings universitet SE-581 83 , Sweden 2011

[15] Major Scott W. Walker, –Integrating Department of Defense Unmanned Aerial Systems into the National Airspace Structure||, Kansas 2010-01

[16] Thomas P. Ehrhard, _Air Force UAVs –The Secret History|| ‘ , A Mitchell institute study July 2010.

[17] STEVEN JZALOGA, IAN PALMER, –Unmanned Aerial Vehicles Robotic Air Warfare 1917-2007||, 2008 Osprey Publishing Ltd.

[18] Christopher T. Petrock Lieutenant Commander, –UNMANNED AIRCRAFT SYSTEMS: THE ROAD TO EFFECTIVE INTEGRATION||, USN, 13 February 2006

[19] –Next Generation Air Transportation System Unmanned Aircraft Systems Research, Development and Demonstration Roadmap|| March 15, 2012

[20] HaiYang Chao, YongCan Cao, and YangQuan Chen, –Autopilots for Small Unmanned Aerial Vehicles: A Survey||, International Journal of Control, Automation, and Systems (2010), < <http://www.springer.com/12555>>

[21] Javier Bilbao, Andoni Olozaga, Eugenio Bravo, Olatz García, Concepción Varela and Miguel Rodríguez, –How design an unmanned aerial vehicle with great efficiency in the use of existing resources||, INTERNATIONAL JOURNAL OF COMPUTERS Issue 4, Volume 2, 2008

[22] .L. Cummings,1 S. Bruni, S. Mercier, and P.J. Mitchell, –Automation Architecture for Single Operator, Multiple UAV Command and Control||, M The International C2 Journal | Vol 1, No 2, 2007

[23] Don Sullivan, Joseph Totah, Steve Wegener, Francis Enomoto, Chad Frost, John Kaneshige and Jeremy Frank, –Intelligent Mission Management for Uninhabited Aerial Vehicles|| , NASA Ames Research Center, Moffett Field, CA. 94035

[24] Matthew DeGarmo* and Gregory M. Nelson, –Prospective Unmanned Aerial Vehicle Operations in the Future National Airspace System||, The MITRE Corporation, Center for Advanced Aviation System Development, McLean, Virginia 22102, American Institute of Aeronautics and Astronautics

[25] Zak Sarris STN ATLAS-3Sigma AE and Technical University of Crete DPEM, –SURVEY OF UAV APPLICATIONS IN CIVIL MARKETS (June 2001)|| 73100 Chania, Crete, Greece

[26] Raj Jaini Washington University in Saint Louis and Fred L. Templinii The Boeing Company , –Wireless Datalink for Unmanned Aircraft Systems: Requirements, Challenges and Design Ideas, American Institute of Aeronautics and Astronautics [27] –Unmanned Systems Integrated Roadmap FY2011-2036|| [28] –Unmanned Systems Roadmap 2007-2032||

[29] Reg Austin Aeronautical Consultant, –UNMANNED AIRCRAFT SYSTEMS UAVS DESIGN, DEVELOPMENT AND DEPLOYMENT||, A John Wiley and Sons, Ltd., Publication [30] –UAS ROADMAP 2005- 2030||

AUTHORS BIOGRAPHIES



L. Subhashree is currently pursuing final year in the department of Electronics and Communication Engineering at Alpha College of Engineering, Anna University in Chennai, Tamilnadu, India. She is very much interested Research and Development in the field of UAV. and international conferences.



T.Kousalya is currently pursuing final year in the department of Electronics and Communication Engineering at Alpha College of Engineering, Anna University in Chennai, Tamilnadu, India. She is very much interested Research and Development in the field of UAV. and international conferences.



T.Aruna is currently pursuing final year in the department of Electronics and Communication Engineering at Alpha College of Engineering, Anna University in Chennai, Tamilnadu, India. She is very much interested Research and Development in the field of UAV. and international conferences.



G.TonySanthosh is currently an Assistant Professor in the faculty of Electronics and Communication Engineering Department at the Alpha College of Engineering in Chennai, Tamilnadu, India. He is pursuing PhD in Anna University He also presented various academic as well as research-based papers at several national and international conferences.