

Embedded Web Server for Agriculture Sector

Arockia Panimalar.S¹, Abirami.P², Priyadharshini.P³, Vijayabharathi.R⁴

¹ Assistant Professor, Department of BCA & M.Sc SS, Sri Krishna Arts and Science College, Tamilnadu, India

^{2,3,4} III BCA, Department of BCA & M.Sc SS, Sri Krishna Arts and Science College, Tamilnadu, India

Abstract - A computerized accuracy farming framework is utilized to advance the agricultural sector of the nation into a next level. Different present day innovations and new thoughts are incorporated to develop the farm in a specialized way for accuracy agriculture. The framework is mostly depending on sensors and microcontroller. In view of the sensor yield which is put on the ranch, cultivate parameters are measured and yield esteem is given to Arduino. Utilizing the edge esteems choice is taken and necessities are told to the user utilizing the web server. Web based cultivating enables the farmer to see the farm status and live video of the farm utilizing remote gadgets. Wireless IP camera encourages live video of the farm. This framework is observed to be possible and financially savvy for advancing water assets, vitality proficient, and decrease in fertilizer cost for rural creation and limit natural effects. This framework can possibly draw in the farmers to execute precision farming to adequately use the accessible land resources.

Key Words: Arduino, Online farming, Precision Agriculture, Sensor, Web Server

1. INTRODUCTION

For every minute, the world's population increases by 120 more people and by 2050 the yield of food crops must be increased by at least 70 percent and water consumption to be reduced To maintain pace. Due to some practical failures in the process of harvesting, storage and marketing crops, half of the amount of food production is not usefully consumed. Harvests will have to become more extensive in order to give food to the increasing world population over the next decades [1]. To survive in the growing world population without expanding the cultivated areas at the expense of environment, the farmers should move to intensive cultivation and more productive plants. Unfortunately weather related natural disasters like floods, droughts leads to crop damage and low productivity. Weather related events leads to major part of the crop losses. Weather forecasting plays an important role in farming for irrigation and fertilization. Weather forecasting organization collects data and observation from the local reporting stations. Based on the collected data, forecast is created. Even though thousands of people gets forecasts by local weather meteorologists, it is not possible to provide the accurate forecast right to everyone spread out over wide area in real environment via TV or radio. Loss of crops also occurs due to wrong forecasting or unexpected rainfall after irrigation or fertilization.

Soil possesses various nutrients in different propositions. During the plants growth, the needed nutrients are observed by the plant from the soil. The plant growth drops when the needed nutrient amount is not available in the soil. Naturally, the absorbed nutrients during the plant growth are return back to the soil when plants die and rotten. However, this occurs for plants in forests or plants which are not cultivated and harvested. During the harvesting of the cultivated crops, the nutrients extracted the soil are not returned to the soil leads to nutrient imbalance. For maximum production, the nutrient artificially supplied to the soil. There are three major nutrients needed by the plants: Nitrogen, Phosphorus, and Potassium. The proportion of these nutrients is indicated by numbers called N-P-K numbers. NPK numbers represents the proportion of Nitrogen, diphosphorus pentoxide and potassium oxide in the fertilizer.

Agricultural fields are not regular, leads to a certain strain of plant looks better than the other plants. It arises from the result of different soil properties. The soil properties in a single field are not uniform, that can influence the level of moisture and nutrients that the plant has at its disposal. Another biggest problem for cultivators is parasites. Parasite is an organism which lives in or on other organism and benefits by deriving nutrients at the other expense. For example, hair worms or nematodes are parasites which attack the root zone of the sugar beet. The only way to identify the parasite is to pluck the sugar beet from the ground. In dry areas or in case of inadequate rainfall, irrigation becomes difficult.

Another reason for low productivity is not properly concentrating in soil analysis and pH level of the particular soil. Various modern technologies and new ideas have been developed to promote the agricultural sector of the country to the next level. Many systems developed to erect a farm in more technical manner, from basic conventional methods of farming to technically advanced methods. For instance, in one system irrigation is monitored and controlled remotely using a distributed wireless sensor network with decision support software. The sensor network collects information and is transferred to the controller in the base station using Bluetooth. The major drawback of the system is the coverage area of the Bluetooth which is within 10m [2]. Another system was developed to control irrigation based on electromagnetic sensor which measures soil moisture and reduces the water usage by 53% when compared to sprinkler [3].

In recent years, sensors and wireless sensor networks play an important role in wide range of applications operated in real time [5] [4]. For example, WSN have been implemented in the diagnosis motor fault [5]. Smoke sensor have been used for security purposes to detect fire accidents and send information using wireless networks [6]. The inclusion of WSN in greenhouses made it possible to measure and control parameters like temperature and humidity [7]. Other authors have developed a system based on wetting front detector which collects soil samples of soil water during irrigation and rainy seasons [8]. Recent developments in low cost microcontrollers and sensors lead to low cost automation techniques in agriculture [9]. There are many systems available to monitor various farm parameters like temperature, soil moisture, soil fertility, leaf wetness, water level, parasites detection, weed detection, crop growth and automated irrigation facility [10].

Another automated irrigation system was developed using water level sensor, remote supervision system and GPRS to measure the water level in the agricultural field. Other authors have reported the use of WSN, PC and internet to monitor the field condition. The system implementation relies on the sensors placed in the farmland. Various new wired and wireless sensors are available which are used to monitor and control the farm status and parameters. Based on the measured data from the field, necessary control actions are taken. Some control operations are automatically turning on and off irrigation, determining amount of pesticide and fertilizers needed for the farm. The distribution of nutrients in the soil can be determined by using the gamma-spectrometer.

Among the techniques available for agriculture automation, the most widely used term to overcome these difficulties is precision agriculture. Precision reduces the environmental impacts in several ways including the reduced water usage or the less farm chemicals in water. The system automatically determines the necessary operations for optimization using the data collected from the farm and the surrounding region. Precision agriculture shows the exact best time for harvesting to eliminate crop damage and loss, provides the number of workers are needed at harvest time and also helps for faster delivery of crops to the market. These smart technology development not only found useful in mega farms, it can also be used in small, family run fields, gardens and greenhouses for maximizing production and effectively utilizing the natural resources. Combining modern technologies with other traditional farming methods can be very useful for reducing the usage of resources like water.

Natural weather disaster is the reason for 90 percent of overall crop losses. For satisfactory crop growth proper nutrition is required to maximize production. Soil analysis helps to determine the status of nutrients level in the soil which is important for effective utilization of available land

resources. Low investment for maximum production leads to farmers profit and less environmental impacts. Application of fertilizers in needed amount and required type of fertilizers for the supply of the nutrients significantly increase the yield.

Soil testing can save money by identifying what parts of your farm have low fertility and need extra fertilizer to improve productivity [11]. Soils with higher fertility need less fertilizer. It will also help to plan fertilizer, slurry and manure spreading. Soil testing helps to find out the current fertility level of the soil. It also provides information of the soil pH value which helps to determine the required amount of lime or sulphur to maintain soil pH for maximum productivity and the current availability of nutrients in the root zone. If the proper pH value is not maintained, the nutrients cannot be absorbed by the soil. Soil tests can help farmers to provide proper amount of expensive nutrients to the soil for crop growth. The soil test report will show a lime requirement result to indicate the rate of lime required to increase the soil pH to the correct level. Optimum pH for grassland is 6.2 to 6.5. Fertilizers, insecticides and seeding rates can be formulated by analyzing the properties and current conditions of the soil. Even though various automation methods have developed in the field of irrigation, no sophisticated way is developed in the farmer side to remotely monitor and control the farm status. In this paper, development of the deployment of automatic precision agriculture system with embedded web server is presented. Wireless IP camera is also used to provide live video of the farm.

Embedded web server allows the farmer to monitor and control the farm from anywhere using remote devices. Mobile applications are available to view the farm status online. Precision agriculture based on embedded web server includes advanced sensor which works in both wired and wireless environment. The system identifies the current status and ability to report the information to the farmer for necessary actions. The system improves crop yield, reduces cost and environmental impact.

2. SYSTEM DESIGN

Precision agriculture, method of farming which uses accurate amount of natural resource for plant growth with less environmental impacts and results to maximum production. More advanced technical equipment has been developed in the field of agriculture. The proposed precision agriculture method based on embedded web server has two modules: microcontroller module and web server based module. The block diagram of the system consists of sensor array, power supply, Arduino UNO, Wireless IP camera, motor drive, motor and web server module sensor, Raindrop detection sensor, Spectral sensor, pH sensor and soil moisture sensor.

The entire block diagram of the system is shown in Fig. 1.

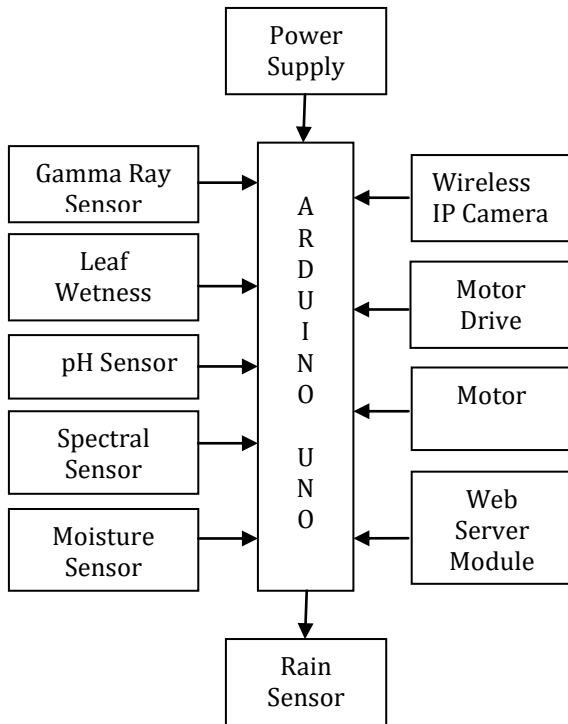

Fig 1: Block Diagram of the Complete System

Sensor array includes six sensors such as Gamma Ray sensor, Leaf wetness detector, pH sensor, spectral sensor, moisture sensor and rain sensor. The sensor output values are given to the Arduino Uno board which transfers the data to the web server using an Ethernet cable. Power supply is given to Arduino UNO and separately to Wireless IP camera. Wireless IP camera provides the live video of the farm which can be seen in remote devices. Mobile application makes the system very feasible. Motor is used for irrigation purposes. Wireless IP camera can be used to detect intruders in the farm. Based on the user requirement, the user or the microcontroller takes decisions based on the sensor output data.

A. Arduino Uno

Arduino Uno is a microcontroller board, designed to make the environment easily accessible. It consists of ATmega328 microcontroller, 6 analog input pin, 14 digital I/O pins, 32 kb Flash memory, 2kb SRAM, 1kb EEPROM. It operates with a clock speed of 16MHz. sensor array consists of six sensors which are connected to the 6 analog inputs of Arduino. Arduino implicitly performs signal conditioning, converts to digital value. Based on these values, it controls the farm. Arduino send the data to the web server using the Ethernet (ENC28J60) cable. From the web server, the farmer can view and control the farm status and parameters using remote devices over the internet.

B. Gamma Ray Sensor

Gamma ray sensor is used to look into the soil usually buried under the farm. This sensor acknowledges the existence of natural radioactivity that is emitted from the isotopes like potassium 40. Gamma spectrometer can be used to identify the distribution of the elements in the soil. GE's Scinturion is the gamma ray sensor provides accurate data and operating in a temperature ranges from -4 to 347 °F (-20 to 175°C). It ensures greater stability and minimizes the vibration. It uses stronger material with better transmission properties which enhances sensitivity. It heightens performance and boost power. For optimum electrical performance and compact size, amplifiers, discriminators and high voltage power supplies are integrated with the detector. The sensor gives the output data to the Arduino UNO, used to determine the nutrient level of the soil. This leads to determine the actual need of the fertilizers to the soil. The value can also be displayed in the web server. So, the farmer can monitor the data values at any time.

C. Leaf Wetness Sensor

Leaf wetness sensor (s1169) detects and alarms when the leaves are thirsty. It is a standard leaf sensor that measures water levels of live plants and simple to use in real time environment. Applications of leaf sensor in various fields related to water management, irrigation and Research. The leaf wetness sensor consists of a plastic sensor, which is specially designed to attach on any leaf. This sensor is useful in any agricultural application where it is necessary to determine scab hours. When a plant needs water and becomes dry, it leaves contract. These changes can be measured in terms of electrical voltage. Then the sensor transmits those signals to the microcontroller to automatically start irrigation and send information to the farmer based on the requirement. It is mainly used to monitor and control agricultural water demand. It is estimated that one sensor is enough to cover 20 to 30 acres of farmland to provide the details to irrigate the entire farmland.

D. pH Sensor

pH sensor is used to measure the pH (alkalinity or acidity) of the soil which is inserted into the soil. pH value ranges from 0 to 14 and the optimum value is 6.2 to 6.5. Nonoptimum pH value results to lower availability of the nutrients in the soil, and poorer response to applied fertilizers. When the pH value is low, lime will be added to the soil. When the pH value is high, sulphur will be added to the soil to maintain the correct pH value. The pH meter consists of pH Glass & Reference electrode in a single entity. The electrode length is 160 mm and electrode diameter is 12 m. pH meter reads value front the soil and sends data to the Arduino.

E. Spectral Sensor

Spectral sensor is used to detect parasites presence in the plants. Most of the sunlight falls on the plant is reflected immediately. But part of light goes into the leaf, transmitted by photosynthesis and is then reflected back. A plant reflection signal depends on the stress it is under. For example, when a sugar beet is affected by parasite infestation, it reflects light differently from a healthy plant. Based on the difference in the amount of reflected light, spectral sensor detects the parasites earlier without harming the crop. This will help the farmers to cultivate more resistance or tolerant crops to parasites.

F. Rain Sensor

Rain sensor is usually placed on the plant leaves to detect the rain droplets and sends signals to the controller to turn off the irrigation to optimize the water resources. Wired or wireless type rain sensors can be used based on the requirement irrigation system are available in both wired and wireless type. Various irrigation rain sensors are also available with specific features. One type of sensor called freeze sensor which is used to keep the system from operating in freezing temperatures, particularly used in area with very low temperatures. When the sensor is connected to 5V power supply, the power light is on. In case of no water droplets on the induction plate, DO output is high and the switch light is off. When water drops, DO for low level output, switch light is on. DO TTL digital outputs can be connected to microcontroller to detect rain. Then the microcontroller will stop the irrigation for water optimization.

G. Moisture Sensor

Soil moisture sensor (VH400) is a low cost sensor monitors the water content in the soil. It is usually buried under the soil. It is insensitive to the salinity of the water and does not corrode over time. The operating temperature range is 40° C to 85° C with a supply voltage of 3.3V to 20V. It has faster response time and the prober length can be extended up to 10m. Soil moisture sensor measures the soil moisture content and send the signals to the Arduino. Irrigation will be turned on or off based on the soil moisture value.

H. Wireless IP Camera

Wireless IP camera (DSL930I) is placed on the farm with a power supply. It is used to feed live video of the farm. It has a feature of motion detection which can be used for intrusion detection. When motion is detected, the camera will capture the image, trigger recording and send as e-mail to alert the farmer. It is mainly used to remotely monitor the place over the internet. Mobile application (Dlink Lite) is also available to view the live video of the farm. It has low light sensitivity,

4x digital zoom for close viewing, built in microphone and wireless connectivity. For security requirement, user password protection is also available. Using the wireless IP camera, the farmer can view the live farm status over the internet [12].

I. ENC28J60 Ethernet

The ENC28J60 is an independent Ethernet controller with an industry level Serial Peripheral Interface (SPI). The main purpose of ENC28J60 is to perform as an Ethernet network interface for all SPI equipped controller. The ENC28J60 satisfies all of the IEEE 802.3 specifications. It comprises a number of packet filtering schemes to restrict the flow of incoming packets. It also equipped with an internal DMA module for fast data throughput and hardware assisted checksum calculation, which is used in many network protocols. Two dedicated pins are used to indicate LED link and network activity.

J. Web Server Module

The block diagram of the web server module is shown in Fig. 2. The sensor array measures the farm parameters and the system loads the data to the web server via internet. The information is stored in the web server database. The farmer access the web server using the remote devices [13]. Using the remote devices (smart phones, laptops, tablets, etc) the farmer can monitor and control the farm parameters from any part of the world.

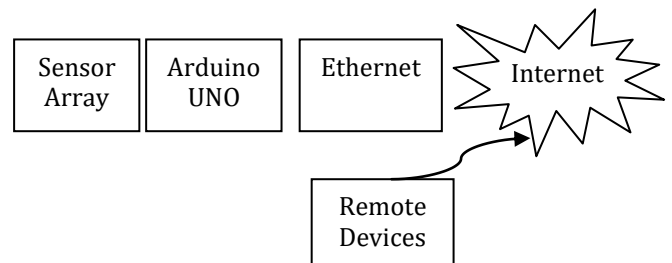

Fig 2: Web Server Based System

3. SOFTWARE DESIGN

The flowchart for the working of whole proposed system as well as software design is shown in Fig. 3. Software design for proposed agriculture system involves two parts: microcontroller programming, GUI design. Initially, the microcontroller receives and reads all sensor data. Using the threshold values, irrigation will be turned on or off. The microcontroller measures the farm parameters and loads the data to the web server via internet. The information is stored in the web server database. Web data base server is responsible for collecting, storing data from the field to the database according to defined parameters like area code or

time. Then it provides a web server functions. System user can visit the data anytime through specific terminal server. Before the farmer logging in to the web server, the farmer should perform authentication. After successful authentication, the farmer can enter into the web server and view farm status.

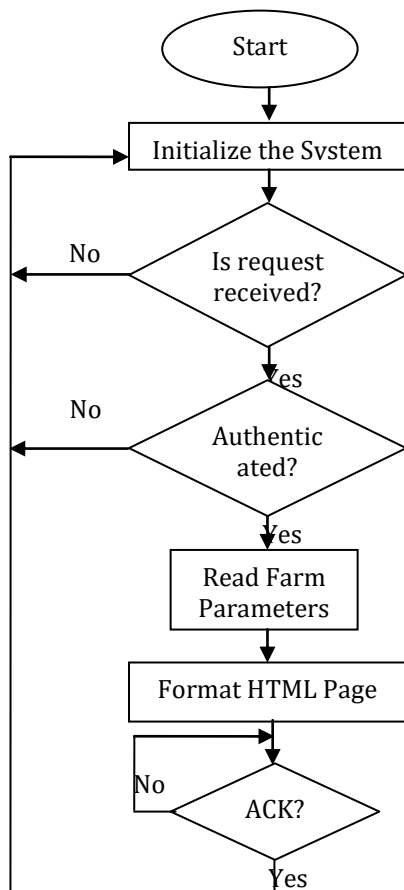

Fig 3: Flowchart of the system

4. HARDWARE IMPLEMENTATION

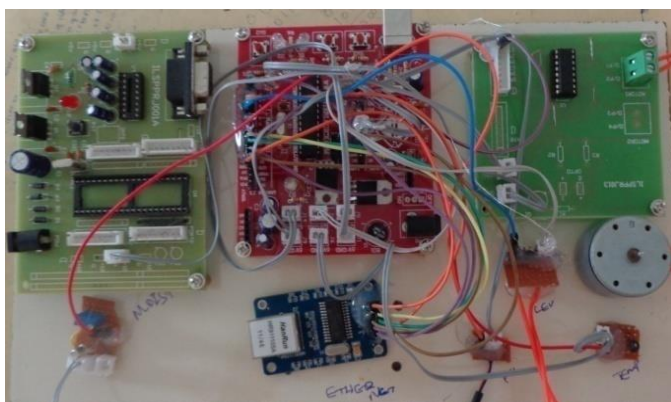

Fig 4: Complete System

Fig. 4 shows the implementation of the complete system including the Arduino Uno, motor drive, Ethernet module. The Ethernet cable is connected from the Ethernet module to the PC. Arduino Uno is connected with power supply and various sensors. The Arduino board composed of an Atmel 8-bit AVR microcontroller. The sensor input values are given to analog pins of the Arduino board. Arduino Uno has inbuilt ADC. The analog values are converted into digital values. The Arduino Uno sends information to the Ethernet module and also connected to the motor drive module.

5. RESULTS

The output window is shown in Fig. 5. It consists of all farm meters such as soil moisture, pH value, Rain detection status, leaf wetness value, spectral value. Motor status allows the farmer to monitor and control the motor. Motor can be switched ON or OFF directly by the user and also by the microcontroller. The user can view the current status of the farm through the online streaming of the video in the screen. Various farm parameter values, date and time are also displayed on the screen. From the sensor, the farmer can switch ON or OFF the motor. Using pH level and NPK value, suitable crop and amount of fertilizer is also determined. The water consumption is reduced by 75% compared to other conventional methods.



Fig 5: Output Window

Table 1: Farm Parameters

Gamma Ray	30%
Solid Moisture	30%
pH Level	6.8 pH
N-P-K	20-13-12
Leaf Wetness	50%

6. CONCLUSION AND FUTURE WORK

In this paper, we have proposed precision agriculture system to optimize water resources, fertilizer, pesticide, insecticide and labour work. The proposed system is well suited for farmer to cultivate in geographically isolated areas. The precision agriculture system implemented was found to be feasible and cost effective for all types of farmland and crops. The system leads to maximum productivity, minimum investment and less impact on the environment. The proposed system consumes only 25% of water than traditional methods of irrigation. The system gives the information about the crops grown in the soil and soil moisture content in the farm. Besides the monetary savings in water use and fertilizers, the importance of the preservation of this natural resource for the next generation justifies the use of this kind of precision agriculture system. The proposed system can be extended to the use of wireless sensors, weed detection using image processing and unmanned vehicles to monitor and control the farm.

7. REFERENCES

- [1] W. A. Jury and H. J. Vaux, "The emerging global water crisis: Managing scarcity and conflict between water users," *Adv. Agronomy*, vol. 95, pp. 1–76, Sep. 2007.
- [2] Y. Kim and R. G. Evans, "Software design for wireless sensor-based site-specific irrigation," *Comput. Electron. Agricult.*, vol. 66, no. 2, pp. 159–165, May 2009.
- [3] M. Blonquist, Jr., S. B. Jones, and D. A. Robinson, "Precise irrigation scheduling for turfgrass using a subsurface electromagnetic soil moisture sensor," *Agricult. Water Manag.*, vol. 84, nos. 1–2, pp. 153–165, Jul. 2006.
- [4] J. Yick, B. Mukherjee, and D. Ghosal, "Wireless sensor network survey," *Comput. Netw.*, vol. 52, no. 12, pp. 2292–2330, Aug. 2008.
- [5] Hou and N. W. Bergmann, "Novel industrial wireless sensor networks for machine condition monitoring and fault diagnosis," *IEEE Trans Instrum. Meas.*, vol. 61, no. 10, pp. 2787–2798, Oct. 2012.
- [6] Gomez and J. Paradells, "Wireless home automation networks: A survey of architectures and technologies," *IEEE Commun. Mag.*, vol. 48, no. 6, pp. 92–101, Jun. 2010.
- [7] D.D.Chaudhary, S.P.Nayse, L.M. Waghmare, "Application of wireless sensor networks for green house parameter control in precision agriculture" published in *International journal of wireless & mobile networks (UWMN)* vol' 3, No.1, Feb 2011.
- [8] Andrew J. Skinner and Martin F. Lambert, "An Automatic Soil Pore-Water Salinity Sensor Based on a Wetting-Front Detector" published by *IEEE Sensors Journal*, Vol, No.1, Jan 2011.
- [9] J. S. Lee, Y. W. Su, and C. C. Shen, "A comparative study of wireless protocols: Bluetooth, UWB, ZigBee, and Wi-Fi," in *Proc. IEEE 33rd Annu. Conf. IECON*, Nov. 2007, pp. 46–51.
- [10] Wang, N. Zhang, and M. Wang, "Wireless sensors in agriculture and food industry—Recent development and future perspective," *Comput. Electron. Agricult.*, vol. 50, no. 1, pp. 1–14, Jan. 2006.
- [11] H.B. Li, R.S. Yang, M. He, Z.H.Chen, "The Fertility Characteristics of the Agricultural Soils from the Inland Plain Region of Shanghai, China", 978-1-4244-4713-8/10/\$25.00 ©2010 IEEE
- [12] K.Sathishkannan, G.Thilagavathi, "Online Farming Based On Embedded Systems and Wireless Sensor Networks," *IEEE International Conference on Computation of Power, Energy, Information and Communication*, 2013.
- [13] Sariga, B.Rajan, "Extensible Embedded Web Server for Online Farming", *International Journal of Scientific & Engineering Research*, vol. 5, No. 10, Oct 2014.