

Design and Fabrication of A Low Cost Submersible ROV for Survey of Lakes

Bharat Kungwani¹, Noopoor Misal²

¹Dept. of Mechanical Engineering, RCOEM, Nagpur, Maharashtra, India

²Dept. of Electronics Design Technology, RCOEM, Nagpur, Maharashtra, India

Abstract - Underwater search robots have been a popular choice for observing the depths of ponds, lakes and oceans alike. The objective of the paper is to design and fabricate such a robot, which will survey and inspect shallow lakes. The Remote Operated Vehicle (ROV) described in the following paper consists of modules which look into the acquisition of data such as videos, images, temperatures, pressures, etc. The device will also determine and identify any undesirable objects lying at the bottom of the lake, to be removed to maintain the ecology of the lake, or respective water body. We propose a low-cost approach with a minimal and simplified configuration of thrusters and communication through wired media.

Key Words: Underwater, ROV, submersible, design, fabrication, low-cost.

1. INTRODUCTION

Remote Operated Vehicle (ROV) falls under the category of Unmanned Underwater Vehicle (UUV) that are used for underwater exploration for carrying out several challenging tasks underwater [1]. ROVs are tools used to inspect, survey and observe underwater objects using cameras in real time. The ROVs are operated using a tether cable linked to human interface devices such as joysticks, keyboards, touch panels, etc. They can also be autonomous and connected to the mother ship. Such ROVs are called Autonomous Underwater Vehicles (AUVs). However, driving ROVs can be a tedious task since they can be subjected to external disturbances and thus need skillful drivers for the fulfillment of any given task. The proposed design of ROV has the application of exploration of lake beds while keeping in mind the cost-effectiveness, portability and ease of control of the vehicle. The priority here was the real-time data telemetry between vehicle and operator. For a successful expedition, the presence of a human operator helps in a mission plan as humans can react to sudden changes caused by the unpredictable nature of the lake environment. Modern ROV systems are categorized by size, depth required, onboard horsepower, capability, and whether they are electro-hydraulic or all electric.

The proposed design of the submersible ROV is a small class ROV that are micro and mini ROVs with power less than 5hp. This paper describes the design and fabrication of a submersible ROV used for the visual inspection of lakes. It

was designed taking into consideration the pressure and the temperature underwater in different parts of the lake. The ROV was designed emphasizing on the reduction of cost, ease of control and portability of the vehicle.

The paper is divided into the following sections:

- Related work
- Mechanical design considerations
- Electronic components
- Fabrication
- Conclusion

2. RELATED WORK

In the later years of the 20th century, the research on manned underwater vehicles boomed to accentuate the understanding of various chemical, biological, geophysical and geological processes transpiring in the depths of lakes, oceans, ponds and seas. The study of phenomena undersea began in the 1970s with Project FAMOUS [2] along the Mid Ocean Ridge [3]. The demands for ROVs began to increase during 1980s and were mostly required by the oil and gas industry [4]. Since then, extensive research has been carried out and the development of UUV nowadays is being done for deployment in several areas of interests. Currently, UUV are used in research in the maritime sector to inspect the ship's hull condition [5]. They are also used in oceanographic discovery and water pollution research [6]. A category of UUV known as Autonomous Underwater Vehicle [AUV] have also been seen which are controlled automatically by on-board microcomputers and can work independently. Whereas ROVs are remotely controlled by the human operator with the help of a cable or wireless communication [7]. ROVs have been in the picture for the detection of underwater archaeological objects and SURF algorithm was developed for the same [8]. Deep water ROVs have been put into motion and also modified to take samples from the sea bed for further research. For the oil industry, ROVs have been proved to be a boon as the deep waters have high water pressure and it is impossible for divers to dive in, [9]. They have been used for the construction of offshore gas and oil fields, as well as for their maintenance. The Mexican Oil [9] and the power industry ROV [10] are a couple of examples of such vehicles. Apart from the main industry specific ROVs, the research based vehicles to enhance knowledge such as "DENA" [11],

“H-ROV” [12] and “Eyeball” ROV [13] have been seen. ROVs have also been used for military applications [14].

Communicating underwater can be a cumbersome task. Both wireless and wired communication have been used so far for the effective communication between the base station and ROV. The sound waves, i.e. acoustics have enabled considerable amount of change in the way of communication but problems with speed, bandwidth, energy of the signal have been recorded [15]. Low frequencies in water are desirable but the implementation requires large transducer sizes which cannot be actualized [15]. For point to point communication, optical communication is done but the scattering causes problems [15]. All wireless communication methods are achievable but they are expensive when looked at practically. Tethered communication is hence preferred over wireless such as optical fiber, Ethernet cable, etc [16].

3. MECHANICAL DESIGN CONSIDERATIONS

3.1 Design of a submersible ROV

The design of a submersible ROV necessitates a detailed consideration of design parameters and operational characteristics. The generic design process consists of the following stages: (i) Definition of problem statement, (ii) Identification of parameters, (iii) Selection of material, (iv) Determination of forces (v) Design.

The operational factors aimed for are: low cost, ease of control, portability and effective survey capabilities [17].

3.2 Definition of problem statement

The problem statement to be dealt with was the surveying of lakes for scientific as well as ecological purposes. It comprised the measurements of temperatures and pressures in various regions underwater and the visual inspection of lake beds along with detection and identification of foreign objects.

3.3 Identification of parameters

The operating conditions for the ROV were found to be: temperatures between 3 °C and 50 °C, working depth of 0 to 100 meters, translucent water with a pH greater than 6 and less than 8, under any type of lighting.

3.4 Selection of material

Keeping in mind the low-cost requirements and the operating environmental conditions, PVC pipe was used for the construction of the hull. The properties of PVC pipe are known to be its considerable weight reduction, good chemical and physical properties such as corrosion resistance, stiffness, shock absorption and neutral chemical behavior.

3.5 Determination of forces

When the ROV is submerged, the magnitude of forces acting on it change drastically. These changes occur due to change in pressure of water caused by variation in depth [18]. The relation can be obtained using the equation (1).

$$\Delta p = \rho \Delta h \quad (1)$$

Where:

Δp = Pressure change [Pa]

ρ = specific weight of the liquid [N/m³]

h = Elevation change [m]

Substituting the values in equation (1), the specific weight of the water is 9805 N/m³ (at 15°C) and a depth of 100 m, a pressure exerted by water column of 0.98 MPa was obtained. Taking into account the forces acting on a hollow cylinder [19], the stresses developed (figure 1), and from the values of strains and their directions, the failure conditions of the structure may be determined (figure 2).

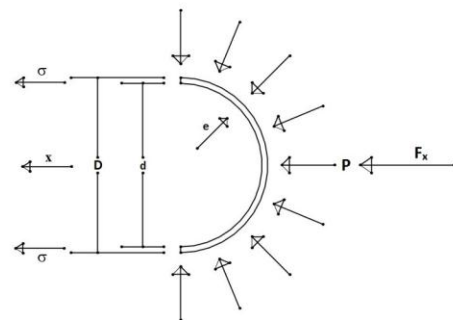

Fig -1: Forces applied to a hollow cylinder

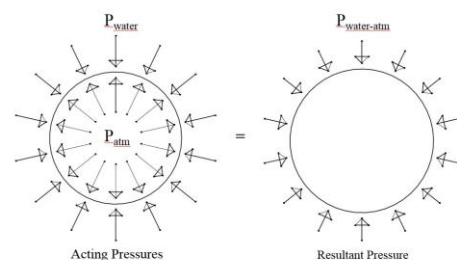

Fig -2: Pressures on a tube submerged in a fluid

The net pressure P_r equals to the difference between atmospheric pressure inside the cylinder and the pressure exerted on the cylinder by the surrounding water, as per equation (2). Substituting the value of pressure exerted by water at a maximum depth (100 m) and the value of internal pressure of the ROV (atmospheric pressure 101,325 Pa) in equation (2), the net pressure of 0.98 MPa was obtained to which the structure is subjected to.

$$P_r = P_{water(abs)} - P_{atm} \quad (2)$$

Where:

P_r = Net Pressure [Pa]

$P_{water(ABS)}$ = Water pressure at 100 m [Pa]

P_{atm} = Atmospheric pressure [Pa]

The critical pressure of a material refers to the pressure it can withstand before failure. The value was found by using equation (3).

$$P_{cr} = \frac{2E}{1-\mu^2} \left(\frac{e}{D-e}\right)^3 \quad (3)$$

Where:

P_{cr} = Critical pressure (failure condition) [Pa]

E = Modulus of elasticity of the material [GPa]

e = Pipe thickness [m]

D = External diameter of the pipe [m]

μ = Poisson's ratio

Substituting the values in equation (3), elasticity for PVC as 2.89 GPa, the Poisson's ratio as 0.410, the thickness of the pipe by 0.006 m, and the outside diameter of the pipe as 0.1016 m, a critical pressure of 1.72 MPa was obtained. This was greater than the net pressure acting on the ROV and indicated that the hull would be safe under the working conditions.

3.6 Design of Immersion System

When an object is immersed in a liquid, the liquid generates a force that tends to push the object towards the surface, known as the buoyant force B [20], given by the equation (4).

$$B = \rho_{fluid} g V \quad (4)$$

Where:

B = Buoyant force [N]

ρ = Fluid density [kg/m³]

g = Gravitational acceleration [m/s²]

V = Volume of displaced fluid [m³]

The immersion system facilitates the vertical motion of the ROV in the water. The existing ways for implementing the immersion system are: a) Mechanical method by using propellers to achieve the displacement, and b) Hydraulic method by using ballast tanks which can be filled with water or air in order to submerge or emerge. For the sake of simplicity, the mechanical means of immersion is used. Substituting in (4), density of water is 1000 kg/m³, gravitational acceleration of 9.81 m/s² and the volume of displaced fluid as 0.0031121289 m³, the force was determined to be 30.52 N.

Based on the above result, the force required for immersion and vertically downward motion of the ROV was obtained. To calculate the power required by the propeller to

overcome this buoyant force, the propeller acting in its passage, was assumed to be mechanically similar to a screw, which is governed by the equation relating the diameter and RPM [21]. Consider a fixed screw rotating and a nut engaged with it. With each turn of the screw, the nut advances a certain distance as determined by the pitch of the helix. In a similar manner, the propeller acts as the screw and the surrounding water may be thought of as the nut engaged with it. Hence, rotation of the propeller causes linear relative motion between the water and the propeller along its axis. Therefore, it can be said that the pitch of the helix is the linear distance that the ROV moves inside the water. Using a two-blade commercial propeller of diameter 0.04 m, rotating at 1500 RPM, with a pitch of 0.035 m, an analogy was drawn to a propeller being turned 1500 times in a minute. The linear velocity of the propeller was found to be 3.14 m/s, whereas the force being exerted by the motor was equal to 30.52 N. The required power of the motor was then calculated using equation (5).

$$P = F v \quad (5)$$

Where:

P = Power [W]

F = Force [N]

v = Linear velocity [m/s]

Using above equation, P was found to be 95.83 W. A commercial motor of power 140 W was chosen. To achieve perfect vertical motion and dive, the propeller was located in the centre of the ROV (figure 3) and weights were added to the front to balance the weight of the rear thrust motors.



Fig -3: Location of propulsion and dive motors

3.6.1 Immersion Motor Control System

For the control of the immersion system, a simple variable switch was utilized, where immersion is facilitated by activating the motor which rotates the propeller pushing the ROV downwards. When the motor is deactivated, the buoyant force exerted by the water will cause the ROV to emerge. A pressure sensor is used to determine the depth of the ROV, as the pressure value can be used to directly determine the depth using equation (1). As demonstrated earlier, the pressure value for 100 m depth is 1.08 MPa (absolute).

3.7 Design of the Propulsion System

As in the case of the immersion system, there were two alternatives for design of the propulsion system: a rudder system or a differential drive system. The differential drive system was more advantageous as it can be used in constricted spaces and for variable speeds. The differential drive was chosen and the propulsion system was implemented using two Brushless DC motors, allowing the motion of ROV in forward and reverse directions along with turns, depending on the direction of rotation of both motors. The propulsion system must overcome the frictional resistance offered by the surrounding water.

The resistance offered to the advancement of the ROV is offered by the drag force acting on the front and other parts that oppose the forward or backward motion of the ROV. The propulsion motors are mounted at 90° to the central axis to ensure perfectly horizontal action of forces.

For the propulsion system, a commercial propeller of 0.04 m, with a pitch of 0.035 m is used. In order to obtain the required power in propulsion, a linear velocity of 1 m/s and the force opposing the forward motion of ROV was calculated using equation (6).

After the text edit has been completed, the paper is ready for the template. Duplicate the template file by using the Save As command, and use the naming convention prescribed by your conference for the name of your paper. In this newly created file, highlight all of the contents and import your prepared text file. You are now ready to style your paper.

$$F = 0.5 \times \rho \times C_d \times A \times V^2 \quad (6)$$

Where

F = Force acting on the ROV [N]

ρ = Fluid density [kg/m³]

C_d = Coefficient of drag

A = Area of contact [m²]

V = Linear Velocity of ROV [m/s]

Substituting the value of required velocity, coefficient of drag as 0.8 and area of contact of front region of ROV, the force was obtained to be 64.8 N.

Another component of drag force resisting the horizontal motion of ROV is the skin friction drag [22], acting along the cylindrical surface area and was found using the following equations.

$$Re = \frac{VL}{\nu} \quad (7)$$

$$C_f = \frac{1.328}{\sqrt{Re}} \quad (8)$$

$$F_s = C_f \frac{\rho V^2}{2} A_s \quad (9)$$

Where:

Re = Reynold's number

L = Length of ROV [m]

ν = Kinematic viscosity [m²/s]

C_f = Coefficient of skin friction

F_s = Skin friction drag [N]

A_s = Lateral surface area [m²]

Kinematic viscosity of water was taken as 1.15 × 10⁻⁶ m²/s (at 15 °C), and the values for length of lateral surface area of ROV were substituted. Using equation (7), Reynold's Number was found to be 308695.65, therefore flow is laminar. By equations (8) and (9), the skin friction drag acting on the ROV was evaluated to be 0.135 N. Therefore, the net force to be overcome by the propulsion system is 64.935 N (drag + skin friction).

4. ELECTRONIC COMPONENTS

The selection of electronic components was based on a technical research. The requirements of the ROV were straightforward. The exploration of the lake bed along with the underwater objects was to be done, keeping in mind the pressure under the water and the variations in the temperature of the lake. The movement of the ROV was to be done by motors which were manually controlled at all times. The mentioned factors along with the overall cost of the vehicle, i.e. the economical nature of the vehicle were taken into consideration before finalizing the electronics components.

4.1 Pressure and Temperature Sensor

We used the MS5803-14BA sensor. This sensor measures the absolute pressure of the fluid around it which includes water, air, and anything that acts as a viscous fluid. Using this sensor, we determined the pressure exerted on the ROV and the various depths of water it moved in. The sensor works on Serial Port Interface (SPI) and Inter-Integrated Circuit (I2C) Protocol which is used in most modern microcontrollers.

MS5803-14BA provides a precise digital 24-bit pressure and temperature value and various operation modes incorporated allow the user to optimize for conversion speed and current consumption. The temperature range detected is -40°C to +85°C and the maximum pressure detected is 14 bar.

4.2 Brushless DC Motors

Brushless DC motors (BLDC) were a wise choice over the brushed DC motors for a submersible ROV because they are waterproof. BLDCs are more efficient and can achieve higher speeds due to the lack of brushes. There were 3 motors used in the ROV, two for thrust and one for immersion.

The motor chosen for operating the submersible ROV was NTM Prop Drive 28-30A 750kV/140W. It works on 12V DC power supply and can achieve a speed of maximum 750 rpm/V. Maximum current drawn by the motor is 20A. This was apt for the ROV to survey the underwater and provide real time video of it.

To control the speed of the BLDC motor, a device known as Electronic Speed Controller (ESC) was employed. The microcontroller feeds the Pulse Width Modulation (PWM) signals to the ESC. The duty cycle of the PWM will define the speed of the BLDC motor. The rating of the ESC used in the submersible ROV was 12V/30A. The ESC was also used to change the direction of the ROV. It also works as a dynamic brake. An ESC has 3 different wires, one wire will plug directly into the main battery of the ROV. The second wire will plug into the receiver's throttle channel. And the final wire will power the motor. 3 ESCs were operated, each for one BLDC motor.

USB Camera and Remote Control

Focusing on the cost-effectiveness of the submersible ROV, the USB camera chosen was a cheap one. The camera is a simple webcam. A model named Quantum QHM495LM seemed apt for our purpose. It has 6 light sensors, image control, and 25MP resolution. It also has a feature of clicking still pictures. It has an angle of view of 58 degrees. The frame rate of the camera is 30 fps. The interfacing of the camera was directly done with the laptop using a 100m long USB 2.0 cable.

Dual axis analog joysticks were integrated onto a single remote control. The joysticks determined the behaviour of the ROV as per the user/driver requirement. The control of the immersion system, i.e. a variable switch was also incorporated to vary the depth of the ROV underwater.

4.3 Microcontroller

Microcontroller is the heart of any electronic system. PIC16F877A was chosen due its various features such as ease of programming, high-speed flash memory, etc. The microcontroller also has SPI and I2C interface required for the pressure and temperature sensor as mentioned earlier. It only has an instruction set of 35 instructions, has 256 bytes of EEPROM, 368 bytes of data memory, and also 8K flash program memory. It is available in 28-pin, 40-pin, 44-pin packages. Here, the 44-pin PDIP package was utilized. Maximum operating frequency on which the PIC16F877A works is 20Mhz. It has 4 input/output ports with dual functionality namely, Port A, Port B, Port C and Port D.

Since the operating voltage of the microcontroller is from 2.0V to 5.5V, a voltage regulator was provided at the input of the microcontroller. The 7805 IC, whose designated task is to provide a constant voltage of 5V was incorporated on the circuit board. The interfacing of the MS5803-14BA sensor breakout board was simple and the readings of both pressure and temperature were recorded. The programming of the microcontroller was done in Embedded-C.

4.4 Power Supply

The entire electronic circuit was given the power supply of 11.1V using a lithium polymer (LiPo) battery. The battery consisted of 3 LiPo cells and had a capacity of 2200mAh. The battery is rechargeable. However, as fore mentioned, the microcontroller had its own voltage regulator at 5V. Similarly, the MS5803-14BA sensor also had a maximum operating voltage of 4.0V. Another voltage regulator which regulated the voltage to 3.3V was incorporated on the circuit board.

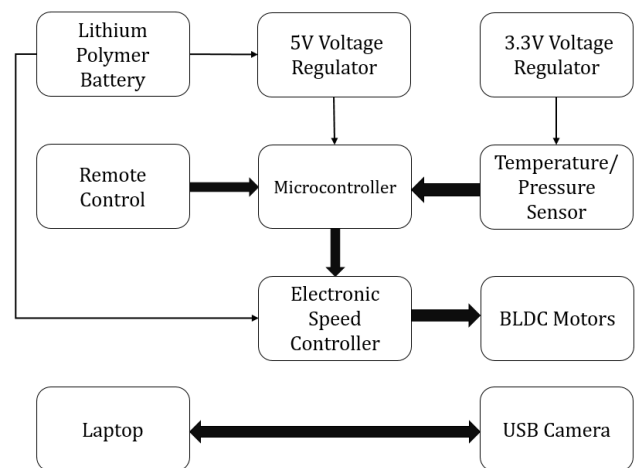

Fig -4: Block Diagram of Electronic System

5. FABRICATION OF ROV

We commenced the fabrication of the ROV with the definition of specifications. The main factors to be considered were construction of main hull, size and the ease of modification thereof. The key requirements deliberated while fabrication were the tightness and rigidity of the assembly as the operating conditions of ROV are underwater and uncertain.

PVC schedule 40 pipe of 4-inch diameter was used for construction of the main hull in view of space required by the internal components while keeping the size minimal. For isolation of the immersion system from internal components and its mounting, a 3-inch PVC Schedule 40 pipe was chosen. The motor mounts were made using aluminium 'L' clamps and at the front, a clear acrylic dome was installed to enable the survey without exposing the camera to the water and eliminating the need for special waterproofing. LED lights were installed with the camera for illumination.

The immersion motor was mounted inside the 3-inch pipe using aluminium mountings and three holes were drilled in the back cover for the tether and propulsion motor wires. The propulsion motor mountings were made so as to minimize the effective width of the ROV while maintaining a safe distance of the motors from the tether to prevent entangling with the propellers.

To prevent water leakage into the ROV and keep the electronic components safe, a three-stage procedure was followed. At first, M-Seal, a multipurpose sealant was applied on all joints and overlapping surfaces. Then, the entire ROV was coated with a waterproofing acrylic elastic to cover up any gaps left in the first step. At last, the process was completed by applying an oil based low odour waterproofing paint for scratch protection of acrylic coating and aesthetic purposes. The finished ROV is shown in figure 5.



Fig -5: Picture of Fabricated ROV

6. CONCLUSION

Submersible ROVs are the best tools for inspection and survey of natural as well as artificial water bodies. The smaller ROVs can be used to gain knowledge required by local fisherman and acquisition of required data for scientific purposes. The ROV presented in this paper can be used for the same in lakes and rivers due to its low cost, small size and easy control. It is shown in this work that effective tools may be developed using low cost and easily available materials for such applications.

REFERENCES

- [1] M.S.M. Aras, M.N. Kamarudin, A.S. M Nor, H.I Jaafar, H.N.M Shah, A.M Kassim, M.Z.A Rashid, "Development and modelling of unmanned underwater glider using the system identification method," *Journal of Engineering and Technology*, Vol. 56, pp. 136-145, October 2013.
- [2] R.D. Ballard, W.B. Bryan, J.R Heirtzler, G. Keller, J.G. Moore and Tj. Van Andel, "Manned submersible observations in the FAMOUS area: mid-Atlantic ridge," *Science*, vol. 190, pp. 103-108, 1975.
- [3] J.R. Heirtzler and T.H. Van Andel, "Project FAMOUS: Its origin, programs, and setting," *Geol. Soc. Am. Bull.*, vol. 88, pp. 481-487, 1977
- [4] The Remotely Operated Vehicles Committee of the Marine Technology Society (MTS ROV), Citing Internet sources URL <http://www.rov.org/rov>
- [5] F. A. Azis, M. S. M. Aras, M. Z. A. Rashid, M. N. Othman, and S. S. Abdullah, "Problem identification for underwater remotely operated vehicle (ROV): A case study," *Procedia Engineering*, Vol. 41, pp. 554560, 2012.
- [6] J. N. Lygouras, K. A. Lalakos, and P. G. Tsalides. "THETIS: an underwater remotely operated vehicle for water pollution measurements". *Microprocessors and Microsystems*, 22(5), pp. 227237, 1998.
- [7] S. Soyulu, A. A. Proctor, R. P. Podhorodeski, C. Bradley, and B. J. Buckham, "Precise trajectory control for an inspection class ROV," *Ocean Engineering*, 111, pp. 508-523, 2016.
- [8] Sakagami, Norimitsu, et al. "Observation support system of an ROV for underwater archaeology." *Intelligent Informatics and Biomedical Sciences (ICIIBMS)*, 2015 International Conference on. IEEE, 2015. Salgado-Jimenez, T., et al. "Deep water ROV design for the Mexican oil industry." *OCEANS 2010 IEEE-Sydney*. IEEE, 2010.
- [9] T. Salgado-Jimenez , J.L. Gonzalez-Lopez, J.C. Pedraza-Ortega, L.G. García-Valdovinos, L.F. Martínez-Soto and P.A. Resendiz-Gonzalez, "Design of ROVs for the Mexican power and oil industries," in proceedings of the 1st International Conference on Applied Robotics for the Power Industry (CAPRI), 5-7 October 2010, Montreal, QC, Canada, pp. 1-8.
- [10] N.H. Tehrani, M. Heidari, Y. Zakeri and J. Ghaisa, "Development, depth control and stability analysis of an underwater Remotely Operated Vehicle (ROV)," in proceedings of the 8th IEEE International Conference on Control and Automation (ICCA), 9-11 June 2010, Xiamen, Fujian, China, pp. 814-819.
- [11] G. Meinecke, V. Ratmeyer and J. Renken, "HYBRID-ROV - Development of a new underwater vehicle for high-risk areas," in proceedings of the IEEE Oceans 2011, 19-22 September 2011, Waikoloa, HI, USA, pp. 16.
- [12] I.C. Rust and H.N. Asada, "The eyeball ROV: Design and control of a spherical underwater vehicle steered by an internal eccentric mass," in proceedings of the IEEE International Conference on Robotics and Automation (ICRA), 9-13 May 2011, Shanghai, China, pp. 5855-5862.
- [13] E. Bovio, D. Cecchi and F. Baralli, "Autonomous underwater vehicles for scientific and naval operations," *An nu. Rev. Control*, vol. 30, pp. 117-130, 2006.

- [14] M. Stojanovic, Underwater Acoustic Communications, Wiley Encyclopedia of Electrical and Electronics Engineering, John Wiley & Sons, 1999, revised and updated Sep 2015, pp. 1-14.
- [15] W.H. Wang, X.Q. Chen, A. Marburg, J.G. Chase and C.E. Hann, "A low-cost unmanned underwater vehicle prototype for shallow water tasks," in IEEE/ASME International conference on Mechatronic and Embedded Systems and Applications (MESA), 12-15 October 2008, Beijing, China, pp. 204-209.
- [16] MOTT, Robert L., "Applied Fluid Mechanics (2006), Pearson Education Publishing, Ed 4, Pages 9-13, 23-39.
- [17] FREEDMAN, Roger A., SEARS, Francis W., YOUNG, Hugh D., Zemansky, Mark W. "University Physics" Volume 1 (2004), Pearson Editorial, Ed. 11, Pages 130-131.
- [18] MENDEZ, Manuel Vicente, (1995) "Pressure Pipes In Water Supply Systems ", Editorial Publications UCAB, Ed 1, Pages 4-4.7, 8.5-8.28.
- [19] JEWETT, John W., SERWAY, Raymond A. Physics 1 (2003), Thomson Editorial, Ed. 3, Pages 508-537.
- [20] MOTT, Robert L., "Applied Fluid Mechanics (2006), Pearson Education Publishing, Ed 4, Pages 9-13, 23-39.
- [21] Streeter, Victor; Wylie, E. Benjamin (1975). Fluid Mechanics (6 ed.). McGraw-Hill. Page 274.