

# Modelling and Fuzzy Logic Control of the Pitch of a Wind Turbine

Silpa Baburajan<sup>1</sup>, Dr. Abdulla Ismail<sup>2</sup>

<sup>1</sup>Graduate Student, Dept. of Electrical Engineering, Rochester Institute of Technology, Dubai, UAE

<sup>2</sup>Professor, Dept. of Electrical Engineering, Rochester Institute of Technology, Dubai, UAE

\*\*\*

**Abstract** - Recently, the renewable energy, especially wind energy, has been paid much attention due to the energy shortage and environmental concern. As the penetration of the wind energy into the electrical power grid is extensively increased, the influence of the wind turbine systems on the frequency and voltage stability becomes more and more significant [1]- [4]. Wind turbine rotor bears different types of loads; aerodynamic loads, gravitational loads and centrifugal loads. These loads cause fatigue and vibration in blades, which cause degradation to the rotor blades. These loads can be overcome and the amount of collected power can be controlled using a good pitch controller (PC) which will tune the attack angle of a wind turbine rotor blade into or out of the wind. Each blade is exposed to different loads due to the variation of the wind speed across the rotor blades. For this reason, individual electric drives can be used in future to control the pitch of the blades in a process called Individual Pitch Control. In this thesis work, a new pitch angle control strategy based on the fuzzy logic control is proposed to cope with the nonlinear characteristics of wind turbine as well as to reduce the loads on the blades. A mathematical model of wind turbine (pitch control system) is developed and is tested with Fuzzy Controller and conventional PID Controller. After comparing the proposed strategy, the simulation results show that the Fuzzy logic controller has the optimum response as it controls the pitch system as well as the disturbances and uncertain factors associated with the system.

**Key Words:** Energy, Wind-Power, Pitch Controller, PID, Fuzzy Controller.

## 1. INTRODUCTION

Energy crisis is one of the biggest problems faced by people in the twenty-first century. The increase in the demand for electric energy along with the availability of limited fossil fuels have together contributed to the need for shifting from the human dependency on conventional resources for energy to the renewable energy resources. There are three important renewable energy resources available to us: solar, gravitational and geothermal energy. Wind energy is one of the indirect consequences from the incident solar energy, promoting air circulation between hot and cold zones [1]. The kinetic energy present in the wind can be converted to mechanical energy by using a wind turbine and further into electrical energy by using a wind turbine generator.

## 2. MOTIVATION

To increase the power capacity of the wind turbine, larger rotors are being built which causes an increase in aerodynamics and other loads across the blades. The aerodynamics and other loads contribute to fatigue failure which results in a decrease in the lifespan and efficiency of the wind turbine [5]. With the help of good pitch angle controllers, the lift profile of the rotor blades can be altered which results in a reduction of the aerodynamics and other loads across the blades. This mechanism uses the fact that much of the fatigue-causing loads are partly deterministic, periodic and vary slowly over a fixed time [7]. Therefore, in this thesis the main goal is to design an optimum controller to control the pitch angle of the wind turbine system so that the loads on the blades are reduced. Reduction in the loads on the blades will ultimately help to improve the performance, efficiency and power output daily of the wind turbine.

## 3. Control Techniques of Wind Turbine System:

The wind energy captured by the turbine can be increased by the following two control strategies: pitch control and stall control. The initial step in both strategies is to check the turbine's power output several times per second using an electronic controller. In case the output power is too high, a signal is sent to the blade pitch mechanism because of which the rotor blades turn slightly out of the wind, adapting the attack angle. Once the wind drops, these blades are turned back into the wind. Turbines with this type of control mechanism are known as pitch-controlled wind turbines.

In the stall control technique, the rotor blades are fixed onto the hub at a fixed angle. But the geometry of the rotor blade is aerodynamically designed in such a way that it ensures that from the moment the wind speed becomes too high, it causes turbulence on the side of the rotor blade which is not facing the wind, creating a stall which prevents the lifting force of the rotor blade from acting on the rotor [1]. In modern turbines, the pitch control technique is used because it helps in controlling the output power simultaneously operating at variable speed to control tip speed ratio and so the power extraction for different wind speeds [8].

#### 4. Model of the Wind Turbine System

The block diagram of a typical wind turbine system model is shown in the figure below [6]. In the following sections, the pitch actuator model and the drive terrain model are explained.

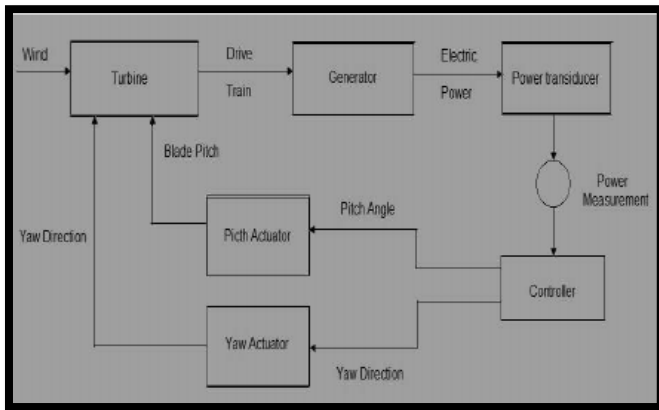

Figure 1: Wind Turbine System Feedback Control System Model

#### 5. Pitch Actuator Model

The pitch actuator is used to turn blades along their longitudinal axis. The actuator model describes a dynamic behavior between a pitch demand, from the pitch controller and measurement of pitch angle [6]

The change in pitch angle is given by

$$d\beta / dt = (\beta_d - \beta) / T_\beta$$

$$T_\beta \cdot d\beta / dt = (\beta_d - \beta)$$

$$T_\beta \cdot d\beta / dt + \beta = \beta_d$$

Applying Laplace transforms, we get

$$T_\beta \cdot \beta_s + \beta = \beta_d$$

$$\beta_s (T_\beta \cdot s + 1) = \beta_d$$

$$\beta / \beta_d = 1 / (s \cdot T_\beta + 1)$$

This is the required Transfer Function. The value of time constant of pitch actuator,  $T_p$  can be calculated from initial parameters of Wind Turbine [6] shown in Table I.

Table 1: Parameters of Wind Turbine

Rated generator power, $P_e$	1000 KW
Rated generator speed, $W_g$	1500 rpm
Rated turning speed of rotor, $W_t$	20 rpm
Wind turbine blade radius, $R$	35 m
Reference pitch angle, $\beta_d$	0 to 90 deg
Rate of change of pitch angle	0.6 deg / sec
Control accuracy of pitch angle	0.3 deg
Damping coefficient, $B$	2 N.m / rad / sec
Drive-train inertia, $J_t$	0.75 N.m <sup>2</sup>

$$T_\beta = (\beta_d - \beta) / (d\beta / dt) = 0.3 / 0.6 = 0.5$$

$$\beta / \beta_d = 1 / (0.5s + 1)$$

#### 6. Drive Terrain Model

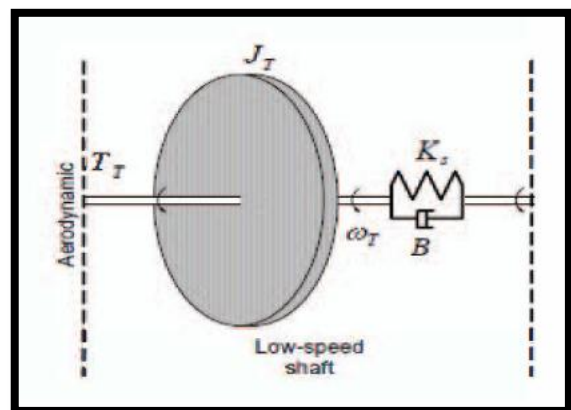

Figure 2: Mechanical model of drive train

The parameters taken while modelling the drive train are shown in Table 2.

Table 2: Mechanical Model Parameters of Drive Train

Parameter	Description	Parameter	Description
$J_T$	Wind turbine inertia [kg.m <sup>2</sup> ]	$w_T$	Wind turbine shaft speed [rad/s]
$J_G$	Generator inertia [kg.m <sup>2</sup> ]	$w_g$	Generator shaft speed [rad/s]
$K_s$	Stiffness coefficient [N.m/rad]	$\theta_T$	Wind turbine shaft angle [rad]
$B$	Damper coefficient [N.m/rad/sec]	$\theta_g$	Generator shaft angle [rad]
$T_T$	Wind turbine torque [N.m]	$1:n_{gear}$	Gear ratio
$T_G$	Generator electro-mechanical torque [N.m]		

The dynamics of drive-train are described by following differential equations

$$J_T \cdot d/dt(w_T) = T_T - (K_s \delta\theta + B\delta w)$$

$$d/dt(\delta\theta) = \delta w$$

Then by using Newton's second law of motion, we get

$$Jdw/dt = T - Bw$$

Applying Laplace transform on both sides

$$J \cdot Ws = T - BW$$

$$J \cdot Ws + BW = T$$

$$W(Js + B) = T$$

$$W/T = 1/(Js + B)$$

This is the required first order Transfer function of Drivetrain. This can also be represented as

$$W/T = (1/B) / ((J/B) \cdot s + 1)$$

$$W/T = (1/2) / ((0.75/2) \cdot s + 1) = 0.5 / (0.375s + 1)$$

Thus, the mathematical model of wind turbine is derived.

### 7. Implementation of Conventional PID Controller

The Simulink model of wind turbine pitch control system with conventional PID Controller is shown in Fig. 3 and the control parameters for the PID controller are shown in Fig. 4.

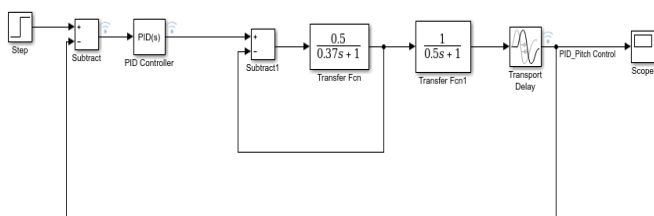

**Figure 3: Simulink diagram of PID Controller Implementation**

Controller parameters

Source:	internal
Proportional (P):	1.29826371423059
Integral (I):	0.413650662438756
Derivative (D):	-2.18301377158872
Filter coefficient (N):	0.157826479197648

**Figure 4: PID Controller Parameters**

### 8. Implementation of Fuzzy Logic Controller

First the rules-surface diagrams for each parameter Kp, Ki, Kd are shown in the figures 5,6 and 7. Then all the 49 rules are displayed in the figure 8. Finally, the Simulink model of wind turbine pitch control system with fuzzy logic is shown in Fig. 9 and the subsystems are shown in Fig 10 and Fig 11.

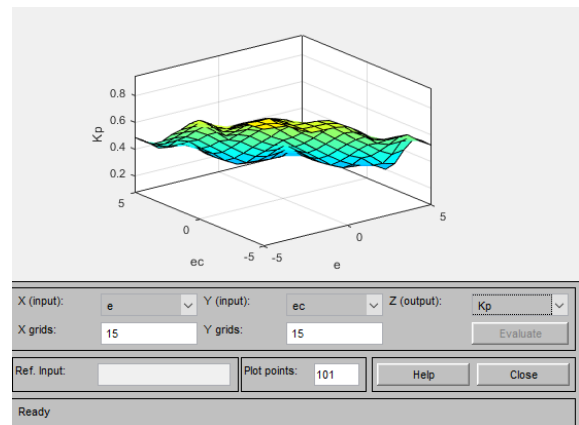

**Figure 5: Surface Rule Diagram for Kp**

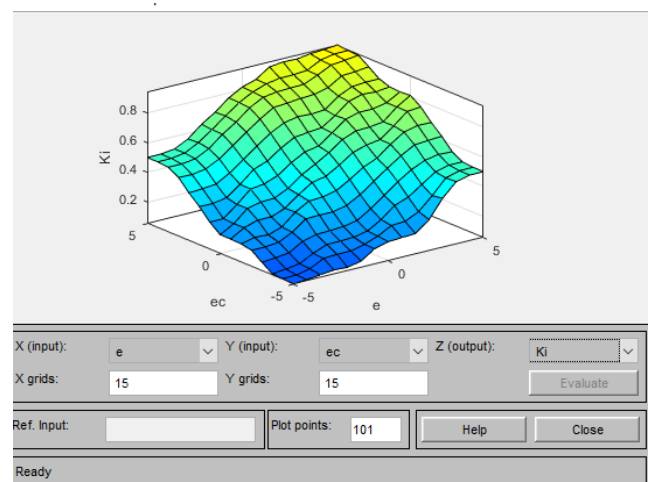

**Figure 6: Surface Rule for Ki**

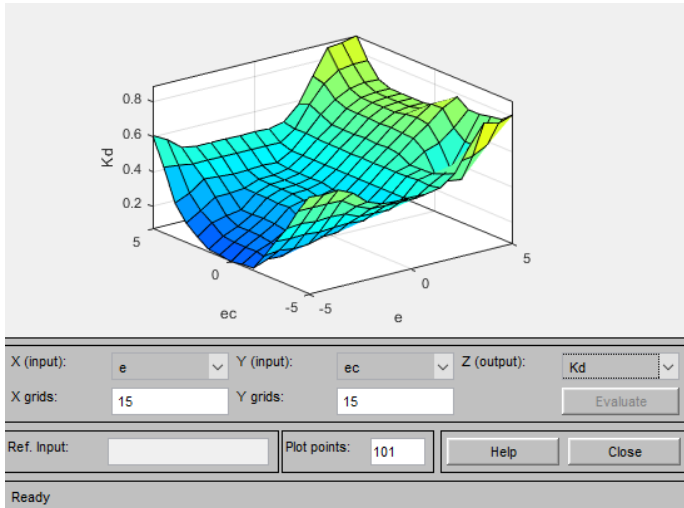

Figure 7: Surface Rule Diagram for Kd

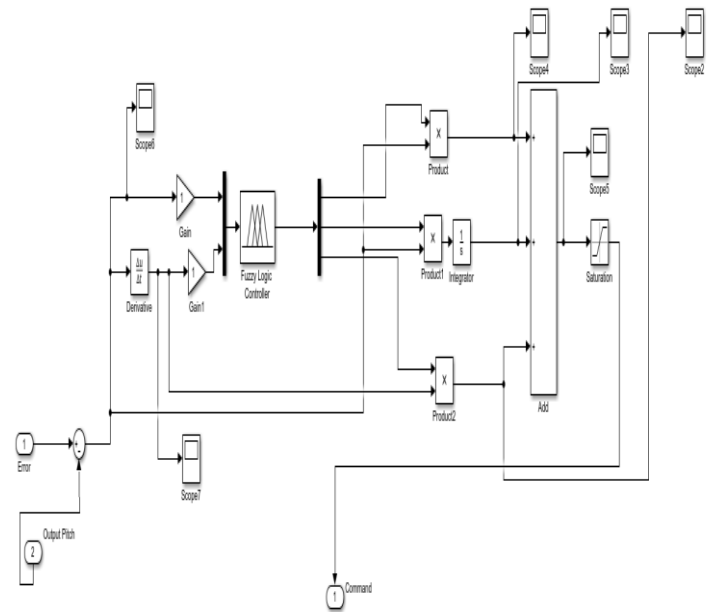

Figure 10: Fuzzy Controller Subsystem

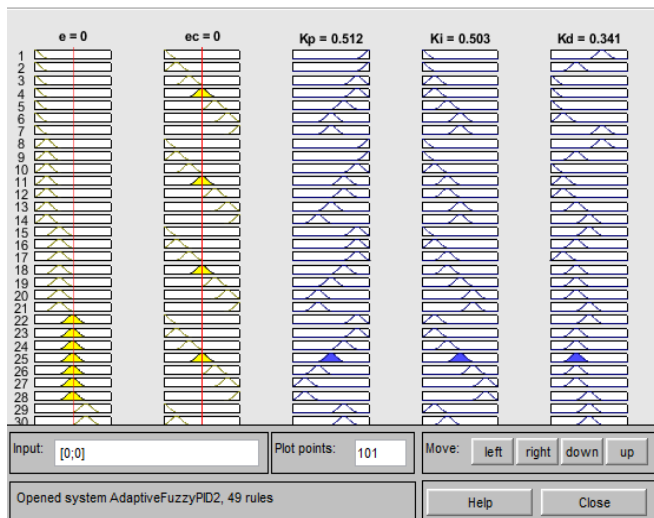

Figure 8: Rule Viewer for Fuzzy Controller

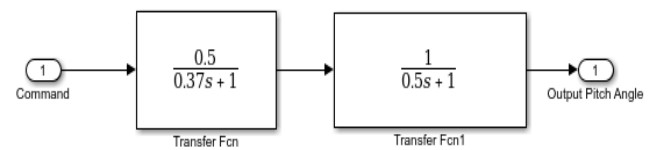

Figure 11: Plant Subsystem

## 10. Simulation and Result of System without Controllers

The figures below show the Simulink model of wind turbine without any controllers and the output graph

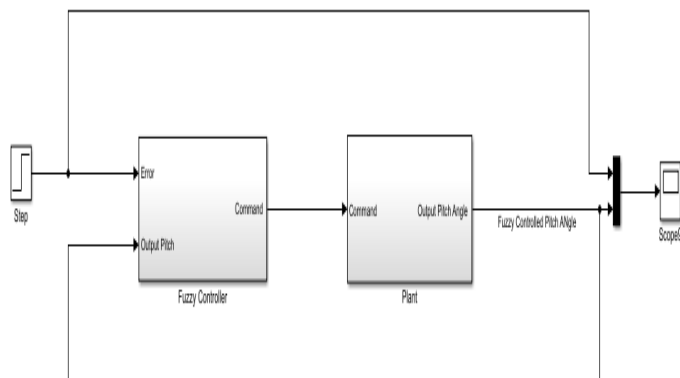

Figure 9: Simulation diagram of fuzzy controller for pitch control system

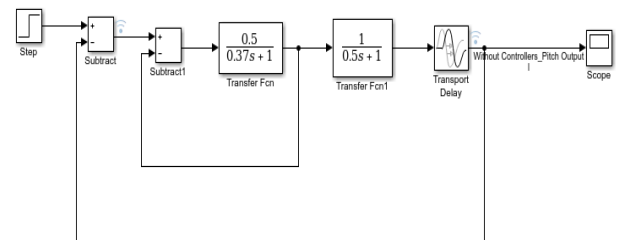
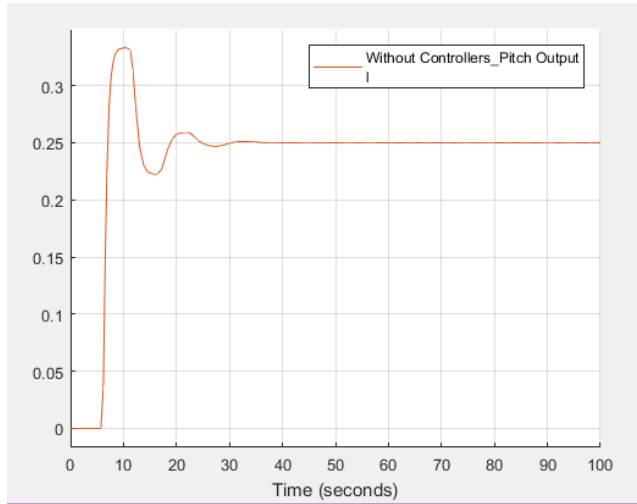

Figure 12: Wind Turbine System Without Controllers



**Figure 13:**The unit step response of wind turbine without controllers

We see that the desired output is not reached as well. Settling time very high. Also the Overshoot and Undershoot is high. Hence, we need to implement controller to overcome these drawbacks.

### 11. Simulation of the Plant with PID Controller

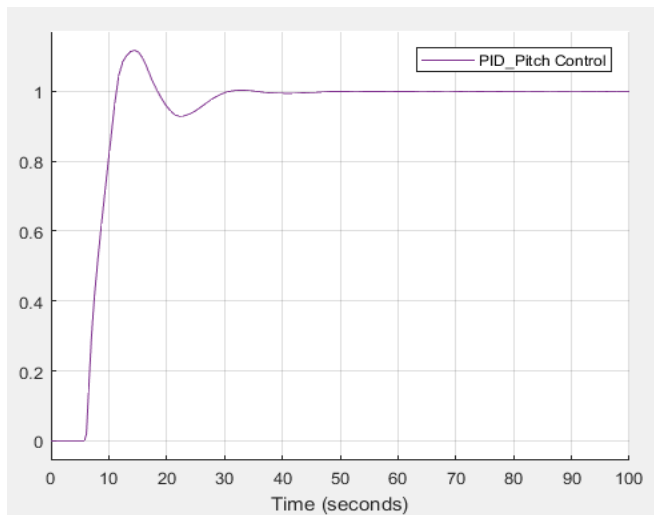

**Figure 14:**The unit step response of wind turbine with PID controller

The unit step response of wind turbine pitch control system is shown in Fig. 17. Time domain specifications are observed from the response graphs and tabulated in Table 6. With PID controller, we observed less rise time, settling time and peak overshoot when compared to the wind turbine model without any controllers.

### 12. Simulation of the Plant with Fuzzy Controller

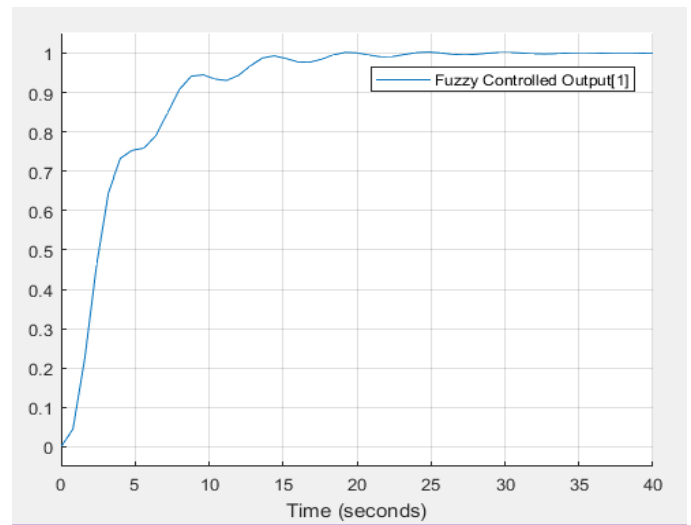

**Figure 15:**The unit step response of wind turbine with Fuzzy controller

The unit step response of wind turbine pitch control system is shown in Fig.18. Time domain specifications are observed from the response graphs and tabulated in Table 6. With fuzzy controller, we observed more rise time and less settling time compared to conventional PID controller and a very little overshoot.

### 14. Comparison of Simulation Results of the Plant using PID, Fuzzy and an Adaptive Fuzzy-PID Controller

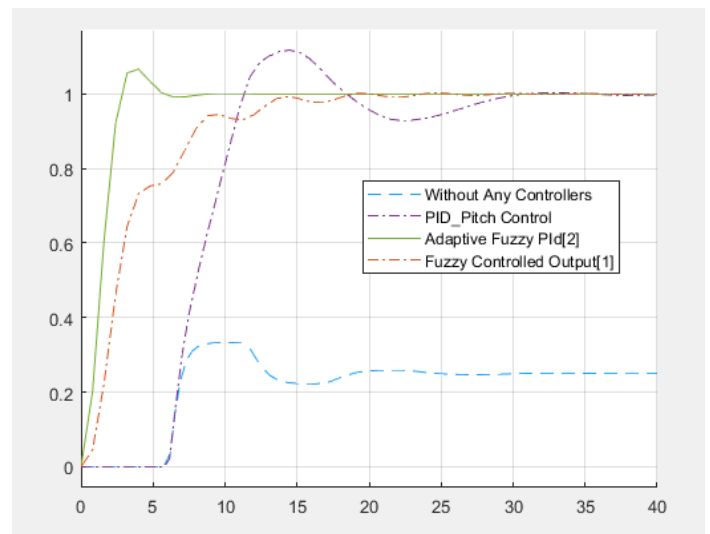

**Figure 16:**Comparison of unit step response of wind turbine pitch controllers

**Table 3: Comparison of Time Domain Specifications of Pitch Control System for Unit Step Input Using**

Time Domain	Without Controller	PID	Fuzzy
Delay Time(s)	8	6	4
Rise Time(s)	0.813	4.21	6.81
Settling Time(s)	38	27	25
Peak Overshoot (%)	32.157	11.8	0.5
Steady State Error	0.75	0	0

From the Table above and Fig.20, we can see that the Fuzzy Logic Controller has the best response when compared to the PID controller. The settling time is fast and overshoot is very less, hence the Fuzzy Logic Controller gives a better control for the pitch angle of the wind turbine system.

### 15. CONCLUSIONS AND FUTURE WORK

In this paper, we developed the wind turbine pitch control system mathematical model and simulated with conventional PID, fuzzy and fuzzy adaptive PID controllers using MATLAB/Simulink to achieve optimum response. We compared the responses in terms of time domain specifications for unit step input using conventional PID and fuzzy logic controllers. Even though, the PID controller produces the response with lower delay time and rise time, it has oscillations with a peak overshoot of 11.8%, which causes the damage in the system performance. To suppress these oscillations fuzzy logic controller is proposed to use. From the results, it can be observed that, this controller can effectively suppress the oscillations and produces smooth response. This technique is much better to realize the control of pitch system and to guarantee the stability of wind turbine output power.

In future, one can use artificial neural networks to control the pitch angle of the wind turbine system and check its performance with the Adaptive Fuzzy PID controller. Also, Individual pitch control method can be used along with the Adaptive Fuzzy PID controller to improve the overall performance of the system.

### REFERENCES

[1]. Civelek, Zafer, Ertuğrul Çam, Murat Lüy, and Hayati Mamur. "Proportional-integral-derivative Parameter Optimisation of Blade Pitch Controller in Wind Turbines by a New Intelligent Genetic Algorithm." IET Renewable Power Generation 10.8 (2016): 1220-228.

[2] C. Tan and H. Wang, "A Review on Pitch Angle Control Strategy of Variable Pitch Wind Turbines", Advanced Materials Research, vol. 772, pp. 744-748, 2013.

[3] Dunne, F. "Optimizing Blade Pitch Control of Wind Turbines with Preview Measurements of the Wind." Order No. 10108716 University of Colorado at Boulder, 2016. Ann Arbor: ProQuest. Web. 4 Feb. 2017.

[4]. Han, Bing, Lawu Zhou, Fan Yang, and Zeng Xiang. "Individual Pitch Controller Based on Fuzzy Logic Control for Wind Turbine Load Mitigation." IET Renewable Power Generation 10.5 (2016): 687-93. Kozak, Peter. "Blade Pitch Optimization Methods for Vertical-axis Wind Turbines." Thesis. ProQuest Dissertations Publishing, n.d. 2016.

[5] Jason T Brown. Montana environmental information centre. <http://meic.org>, 2013.

[6] Novak P, Ekelund T, Jovik I, and Schmidt Bauer B. "Modeling and Control of Variable-Speed Wind-Turbine Drive-System Dynamics," IEEE Control Syst Mag 1995; 15(4), pp. 28-38.

[7] Sharma, R.D. (2013). 'Feedforward Learning Control for Individual Blade Pitch Control of Modern Two-Bladed Wind Turbines'.

[8] S.Suryanarayanan, A.Dixit, "Control of Large Wind Turbines: Review and Suggested Approach to Multivariable Design", Proc. of the American Control Conference 2005, Portland, USA, pp. 686-690.

### BIOGRAPHIES



Silpa Baburajan obtained her B.Sc Electrical Engineering degree from American University of Sharjah (2015) and is currently pursuing her Master's degree in Electrical Engineering, specializing in Control System, at Rochester Institute of Technology (RIT), Dubai Campus.



Dr Abdulla Ismail obtained his B.Sc. ('80), M.Sc. ('83), and Ph.D. ('86) in electrical engineering, from the University of Arizona, U.S.A. Currently, he is working as a professor in the Electrical Engineering Department and assistant to the President at the Rochester Institute of Technology, Dubai, UAE