

STUDY ON INDUCED DRAFT COOLING TOWER PERFORMANCE ANALYSIS IN CAPTIVE POWER PLANT

UMAKANTA B¹, C.N NATARAJ²

¹PG STUDENT, University BDT College of Engineering, Davangere.

²Associate Professor, Department of Studies in Mechanical Engineering, University BDT College of Engineering, Davangere, Karnataka, India.

Abstract: Water cooling is generally utilized as a part of numerous mechanical procedures to control warm expulsion from a hot material surface. Keeping in mind the end goal to control the temperature appropriations, a more profound seeing more exact estimation of splash warm exchange rates is required. In another procedure consolidating test and computational displaying produced for water cooling. It is smarter to comprehend the warmth exchange instruments from the ignition gasses to the chilling water and afterward from the cooling water in the earth. To address this issue a rationale tree is produced to give direction on the most proficient method to adjust and distinguish issues inside cooling framework and timetable fitting support. Liquid flow, Thermodynamics and Heat move are included in building up a cooling framework show and the operation is recognizable to the general working organizations. There will be the examination and parametric examination of the cooling framework show in the rationale tree and the outcomes are compressed as tables and diagrams. The goal is to recognize the few methods for enhancing proficiency of cooling tower. In this investigation examination of a few figuring with respect to the cooling tower.

KEYWORDS- cooling tower, induced draft, approach, range, cooling capacity, evaporation loss, water flow rate, L/G ratio.

1. Introduction

Overheating of machine parts is essential issue in industry. It is caused in light of predictable operation of machine and natural conditions of the earth. Operation can't be stopped or by the day's end the machine can't be offered time to be chilled off and thusly there must be course of action for cooling. Water is the best cooling medium as it is trashy and available in wealth. In any case it must be seen that predictable stream of fresh water to the machine is not judicious as it makes unimaginable waste. Cooling tower is use to achieve the inspiration driving freezing with slightest habit of new water. It circles new water for freezing to the apparatus and usages smallest make up water that is missing in light of dispersal. Beside industry cooled water is required for, for example, ventilation frameworks, or power time. A cooling tower is the apparatus use to reduction the hotness of a water stream through expelling high temperature from water and transmitting it to the air. Cooling tower sort usage of vanishing whereby a little of the water is dispersed into a stirring air stream and thusly

settled into the air. As needs be, whatever remains of the weakened is cooled basically as showed up in the figure. Chilling towers can bring off the water temperature supplementary than devices that usage simply air to scrap warm, like the heater in an auto, and stand along these lines all the more monetarily sagacious and imperativeness profitable.

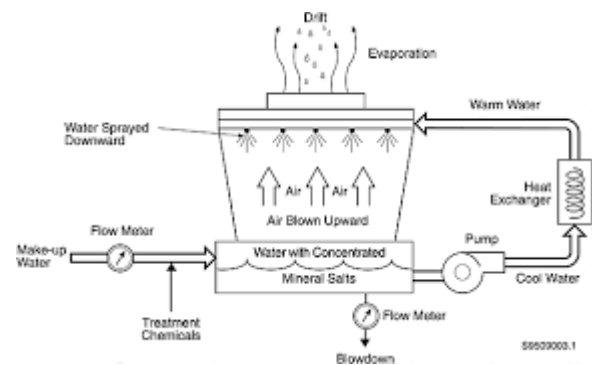

Fig 1:- cooling water system

2. Need & what happens in a cooling tower

- ✓ Evaporation of little piece of cooling tower cools whatever is left of water.
- ✓ Some measure of sensible warmth trade additionally happens.
- ✓ Cooling water gets soaked with oxygen and different gasses show in environment.
- ✓ The current of dry air entering the cooling tower carries with its clean, soil, small scale organic spores, environmental contaminants, and process releases vented to air. The cooling water gets debased.
- ✓ Concentration of salts in cooling water increments. The salts exhibit in cosmetics water get added to the salts abandoned by the dissipated water.
- ✓ Process spills sully cooling water.
- ✓ These changes in cooling water and a portion of the characteristic properties of water prompt issues of erosion, scaling, microbial development and fouling of the framework.

3. Cooling Tower Types

Cooling towers drop into two main types.

- i. Natural draft cooling tower.
- ii. Mechanical draft cooling tower.

3.1 Natural Draft Cooling Tower

Normal draft towers use wide cement fireplaces to current air over the media. For the reason that the expansive dimension of these towers, they are for the most part used for water stream proportions above 45,000 m³/hr. These sorts of towers are utilized just by utility power stations

3.2 Mechanical Draft Cooling Tower

Mechanical draft towers use extensive fans to drive or draw air through flowed water. The waterfalls descending above seal planes, which support increment the interaction period between the water and the air- this amplifies warm exchange between the two. Freezing proportion of Mechanical draft tower rely on their fan distance across and quickness of process. Subsequently, the mechanical draft cooling tower are considerably further generally utilized, the emphasis is arranged them in this part.

Mechanical draft towers are accessible in the accompanying wind stream courses of action:

- A. Counter flow induced draft.
- B. Counter flow forced draft.
- C. Cross flow induced draft.

a. Counter Flow Induced Draft Cooling Tower

In the counter stream prompted draft outline, heated water arrives by the best, whereas the air is presented on the base and departures at the best. Mutually constrained and prompted draft fans are utilized.

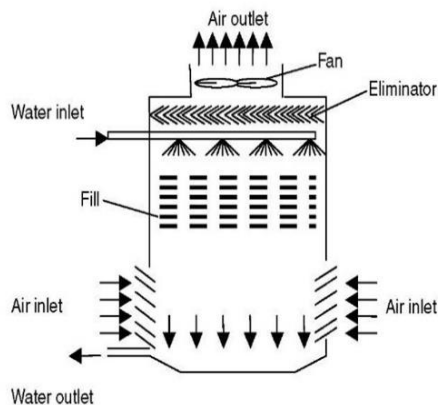

Fig 2:-counter flow induced draft cooling tower

b. Counter Flow Forced Draft Cooling Tower

In some constrained draft hostage stream plan, in any case, the water on the base of the seal is directed to a border rack that capacities as the cool water bowl. Propeller followers remain attached underneath the top to pass the appearance over concluded the tower . Using this outline, the tower is fixed on supports, giving simple entrance near the supporters and their engines.

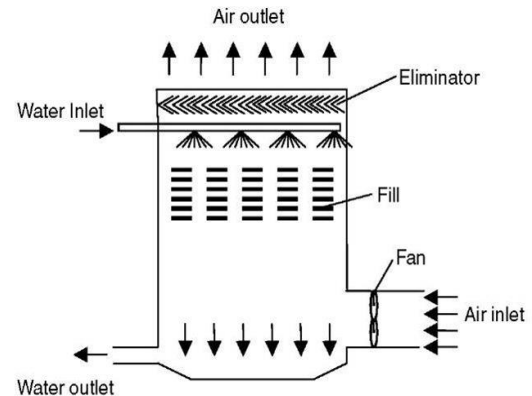

Fig 3:- forced draft cooling tower

c. Cross Flow Induced Draft Cooling Tower

In cross stream incited draft towers, the water pass in at the best and ignores the seal. The air, in any case, is exhibited along the edge either on one side (single-stream tower) or backwards side (twofold stream tower). A prompted draft fan attractions the air over the moistened seal and ejects it through the most noteworthy purpose of the construction.

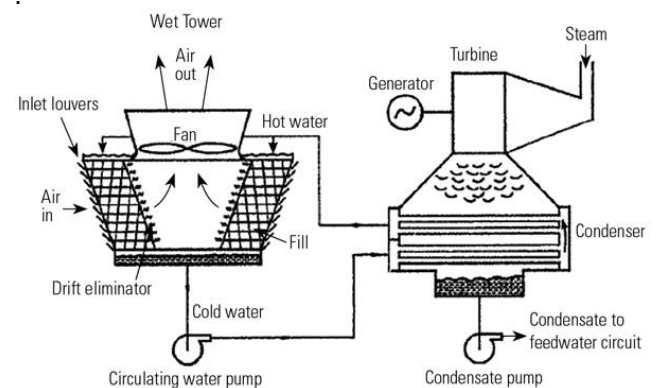

Fig 4:- cross flow cooling tower

Many towers are worked with the objective that they can be gathered together to fulfil the pined for restrain. Thusly, many cooling towers are assemblies of no less than two separate freezing towers or "cells." The amount of chambers they take, e.g., an eight-cell tower, as frequently as possible suggests such towers. Various cell towers can be

lineal , four-sided, or curved dependent upon the condition of the separate cells and whether the air deltas are arranged on the borders or ends of the chambers.

4. Our Cooling Water System

In our plant induced draft counter flow cooling tower are using with six cells back to back configuration.

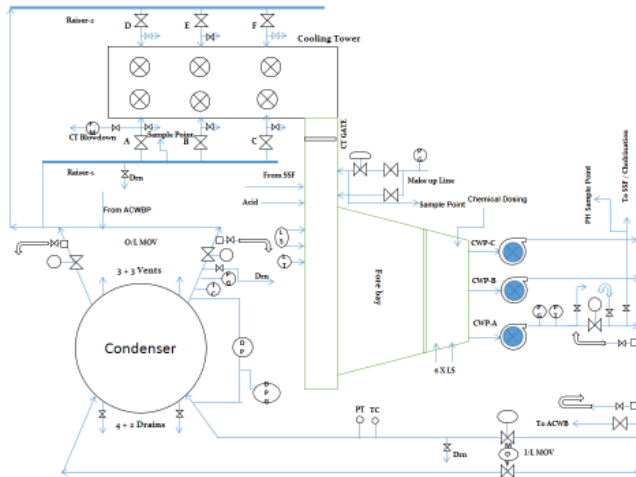

FIG 5:- Structural view of Counter flow induced draft cooling tower

Technical details:

Table -1:-induced draft cooling tower details

Cooling tower	
Type	Induced Draft Counter Flow
Tower Model	84260-6.0-06B
No. of Cells	06 (back to back configuration)
No. of towers	One (1)
Design Circulating Water Flow	18000 M ³ /hr
I/L (Hot) water temp	42 °C
O/L (Cold) water temp	32 °C
Wet bulb temperature	27 °C
Drift Loss	0.02 %
Evaporation Loss	1.44 %
Circulating water Flow	14166 M ³

Total Flow	20166 M ³	
Each Cell	2361 M ³	
Cost	2,62,00,000 RS	
STRUCTURAL DETAILS		
Fans per Cell	one	
Total Number of Fans	Six	
Nominal Cell Dimensions	L X WX M	18.39 X 12.90
Overall Tower Dimensions	L X WX M	55.17 X 25.80
Height-Basin Curb to Fan Deck	M	11.66
Overall Tower Height	M	15.70
Motor data		
No. of Pumps	3 No's	
Pump capacity	8415 m ³ /hr	
Pump speed	590 rpm	
Type of pump	Vertical mixed flow	
Motor Capacity	600 KW	

MATERIAL OF CONSTRUCTION	
Frame work Members	RCC
Casing	RCC
Filling	PVC Film type
Support	RC Beams
RC Beams Support	PVC
Louvers, Material	None
Fan Deck	RCC
Water Distribution – Type	Low pressure non clog spray type
Cold Water Basin – Material	RCC
Furnished By	Paharpur

CT FAN		
Number	One per cell	
Type	Axial Flow propeller type	
Manufacturer	Paharpur	
No. of Blades	Eight (8)	
Diameter	M	10
Fan speed	Rpm	98
Tip speed	m/sec	51.31
fan, driver output	BHP	51.3
Blade Material	GRP51.3	
Hub Material	Fabricated steel HDG	
Air Delivery per Fan	M ³ /hr	1491548

5. Components of Cooling Tower

The elementary apparatuses of an evaporative tower are

1. Frame and casing
2. Fill
3. Cold water basin
4. Drift eliminators
5. Air inlet
6. Louvers
7. Nozzles
8. Fans

1. **Frame and casing :** Maximum towers have helper edges that assistance the outside isolate ranges (lodgings), engines, followers, and diverse parts. With certain slighter plans, for instance, specific crystal fibre parts, the bundling may fundamentally be the edge.
2. **Fill :** Maximum towers use seals to empower warm trade through boosting water and air exchange. Seal can either be sprinkle or film sort.
 - With sprinkle seal, waterfalls above dynamic coatings of even sprinkle slabs, industriously contravention into humbler globules, but also moistening the seal superficial. Flexible sprinkle seal propels favoured warmth trade over the wood sprinkle fill.
 - Film fill contains thin, immovably isolated flexible planes above which the water feasts, encircling a tinny film in interaction with the air. These planes

may be level, layered, honeycombed , or diverse cases. The film sort of seal is the supplementary capable and gives similar warmth move in a more diminutive capacity than the sprinkle seal.

3. **Cold water basin:** The freezing water bowl, arranged nearby the base of the tower, gets the chilled water that streams off over the tower and seal. The bowl regularly has a sump or low point for the frosty water expulsion affiliation. In several tower projects, the icy water bowl is underneath the whole seal.
4. **Drift eliminators :** These catch water beads entangled noticeable all around stream that generally would be lost to the climate
5. **Air inlet :** This is the reason for entrance for the air inflowing a tower. The cove can take up a complete sideways of tower-cross stream plan or be discovered short as a reconsideration or the base of counter stream diagrams.
6. **Louvers :** For the most part, cross-stream towers have delta louvers . The motivation behind louvers is to adjust wind stream into the seal and hold the water inside the tower. Several counter stream tower plans don't need louvers.
7. **Nozzles :** These give the water showers to wet the seal. Constant water dispersion at the highest point of the seal is basic to accomplish legitimate moistening of the whole seal superficial. Spouts container either be settled set up and take either curved or four-sided shower designs or container be a piece of a pivoting get together as initiate in certain roundabout cross -area towers.
8. **Fans :** Both centre point (propellers sort) and spiral followers are used as a piece of towers. Generally, propeller fans are used as a piece of induced draft tower and mutually propeller and outward followers are found in compelled draft towers. Dependent upon their dimension, propeller fans can either be settled or adjustable pitch.
 - Fan abstaining non-programmed customizable pitch sharp edges allows a similar fan to be utilized over an extensive variety of kW with the fan changed in accordance with convey the coveted wind current at the least power utilization.
 - Automatic variable pitch cutting edges can differ wind current in light of changing burden conditions.

6. Tower Materials

In the beginning of refrigeration tower fabricate, towers stood built principally of timber. Wooden parts incorporated the edge, packaging, louvers, fill, and frequently

the cool water bowl. On the off chance that the bowl remained not of wood, it probable of cement. Nowadays, tower makers create towers and tower segments starting an assortment of resources. Regularly a few resources are utilized toward upgrade consumption confrontation, lessen support, and advance unwavering quality and long administration life. Stirred steel, different levels of stainless steel, glass fibre, and cement are generally utilized as a part of tower development and additionally aluminium and different sorts of plastics for a few segments. Wood towers are as yet accessible, however they have glass fibre as opposed to wood boards (packaging) above the timber system. The channel air louvers might be crystal thread, the seal might remain flexible, and the cool water bowl might be strengthened. Bigger tower at times remain finished of cement. Various towers —housings plus bowls—are built of stirred toughen or, wherever a destructive climate is an issue, stainless steel. Once in a while an excited tower abstains a stainless steel bowl. Crystal thread is additionally broadly utilized for refrigeration tower housings and bowls, providing extended lifetime and insurance after the destructive impacts of numerous substances. Plastics are generally utilized for seal, counting PVC, polypropylene, and different polymers. Preserved timber sprinkle seal is as yet determined for wood towers, however elastic sprinkle seal is likewise broadly utilized before water situations command the utilization of sprinkle seal. Film seal, since it suggestions more prominent warmth exchange productivity, remains the seal of decision for requests wherever the coursing water stays for the most part allowed of garbage that might lump the seal ways. Plastics additionally catch extensive usage as spout tools. Numerous spouts are existence finished of PVC, ABS, polypropylene, and glass-filled nylon. Aluminium, glass fibre, and hot-plunged electrifies harden are normally utilized fan resources. Divergent fans are frequently created after aroused steel. Propeller fans are manufactured from aroused, aluminium, or shaped crystal fibre fortified plastic.

7. Cooling Tower Performance

The significant factors, beginning the topic of defining the presentation of cooling towers, are

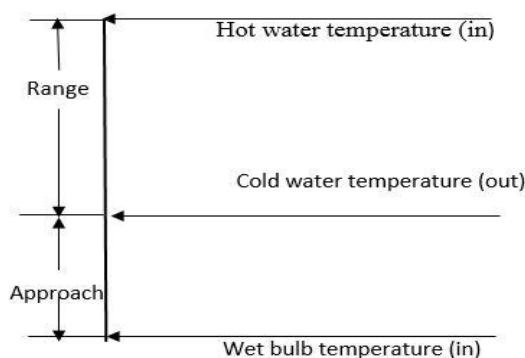

Fig 6:-range and approach

1. **“Range”** is the contrast among the cooling-tower water gulf and vent temperature. A great CT Choice implies that the cooling-tower has possessed the capacity to lessen the water-temperature successfully, and is subsequently presentation admirably.

$$CT \text{ Range } (^\circ C) = [CW \text{ inlet temp } (^\circ C) - CW \text{ outlet temp } (^\circ C)]$$

2. **“Approach”** is the contrast among the cooling-tower’s outlet icy water temperature and surrounding wet knob temperature. Albeit, together variety and methodology ought to be checked, the Approach is a superior pointer of cooling-tower’s execution.

$$CT \text{ Approach } (^\circ C) = [CW \text{ outlet temp } (^\circ C) - \text{Wet bulb temp } (^\circ C)]$$

3. **“Cooling tower effectiveness”** (in percentage) is the proportion of variety, to the perfect variety, i.e., contrast among cooling-water delta temperature and surrounding rainy knob temperature.

$$\text{Effectiveness} = \frac{\text{Range}}{\text{Range} + \text{Approach}}$$

4. **“Cooling capacity”** is the warmth dismissed in kCal/hr or TR, specified as result of mass stream degree of water, particular warmth and temperature distinction.

5. **“Evaporation loss”** is the water amount dissipated for cooling obligation and, hypothetically, for each 10,00,000 kCal warm banned, vanishing amount workings out to 1.8 m³. An exact connection utilized regularly is

$$\text{Evaporation Loss (m}^3\text{/hr)} = 0.00085 \times 1.8 \times \text{circulation rate (m}^3\text{/hr)} \times (T_1 - T_2)$$

$T_1 - T_2$ = Temp. Difference between inlet and outlet water.

6. **“Cycles of concentration”** (C.O.C) is the proportion of broke down objects in coursing water to the disintegrated objects in cosmetics water.

7. **“Blow down”** misfortunes rely on series of focus and the dissipation misfortunes and is assumed by connection

$$\text{Blow Down} = \text{Evaporation Loss} / (\text{C.O.C.} - 1)$$

8. **“Liquid/Gas (L/G) ratio”** of a cooling-tower’s is the proportion among the water and the air mass stream rates. Against configuration esteems, occasional varieties require alteration and fine-tuning of water and wind stream charges to get the

finest cooling-tower's adequacy concluded procedures like water box's stacking variations, sharp edge point modifications.

Thermodynamics likewise manage that the warmth expelled from the water necessity be equivalent to the warmth consumed by the encompassing air.

$$L (T_1 - T_2) = G (h_2 - h_1)$$

$$\frac{L}{G} = \frac{(h_2 - h_1)}{(T_1 - T_2)}$$

Where

L/G = liquid to air mass flow relation (kg/kg)

T₁ = hot water temperature (°C)

T₂ = icy water temperature (°C)

h₂ = enthalpy of air water vapour mixture at exhaust wet-bulb temperature.

h₁ = enthalpy of air-water vapour mixture at inlet wet-bulb temperature.

8. Fill Media Effects

In a refrigeration tower, heated water is dispersed over seal media which streams depressed and is chilled because of vanishing by the mixing air. Air draft is accomplished with utilization of fans. In this way certain power is expended in drawing the water to a stature over the seal and furthermore in fans making the draft. A vitality productive or little power devouring cooling-tower is to consume effective outlines of seal media through proper water dispersion, float eliminator, fan, gearbox and engine. Power reserve funds in the refrigeration tower, with utilization of effective seal configuration.

Function of Fill media in a Cooling Tower:

Warmth trade amongst air and water is affected through surface range of warmth trade, period of warmth trade (connection) and commotion in water affecting careful quality of merging. Seal media in the refrigeration tower is dependable to accomplish all of upstairs.

Splash Fill Media: As the description demonstrates, sprinkle seal media creates the mandatory warmth trade zone through sprinkling activity of water above seal media and henceforth contravention into littler water beads. Accordingly, superficial of warmth trade is the shallow range of the water beads, which is in interaction by air.

Film Fill: In a film seal, water frames a tinny film on both adjacent of seal pieces. In this manner territory of warmth trade is the superficial zone of the seal pieces, which is in interaction with air.

9. Cooling Tower performance analysis calculation

The findings of one typical trial pertaining to the Cooling Towers of a Thermal Power Plant 1x 100 MW is given below

Observations:

- ✓ Type of cooling tower = induced draft
- ✓ Unit load of the station = 100MW
- ✓ Main frequency = 49.99HZ
- ✓ Inlet cooling water temperature = 42 °C
- ✓ Outlet cooling water temperature = 32 °C
- ✓ Air inlet wet bulb temperature = 27 °C
- ✓ Air outlet wet bulb temperature = 37 °C
- ✓ Air inlet dry bulb temperature = 32 °C
- ✓ Air outlet dry bulb temperature = 40 °C
- ✓ Number of CT Cells = 6
- ✓ Dissolved solids in circulating water = 330 ppm
- ✓ Dissolved solids in makeup water = 40 ppm
- ✓ Drift losses = 0.02%
- ✓ Total Measured Cooling Water Flow = 14166 m³/hr
- ✓ Measured CT Fan Flow = 1491548 m³/hr

Analysis at 100% Load Generating power plant

❖ Circulating water flow rate = 14166 m³/hr

✓ **Range:**

$$CT \text{ Range } (^\circ C) = [CW \text{ inlet temp } (^\circ C) - CW \text{ outlet temp } (^\circ C)]$$

$$= [42 - 32]$$

$$= 10^\circ C$$

✓ **Approach:**

$$CT \text{ Approach } = [CW \text{ outlet temp } (^\circ C) - Wet \text{ bulb temp } (^\circ C)]$$

$$= [32 - 27]$$

$$= 5^\circ C$$

✓ **Effectiveness:**

$$CT \text{ Effectiveness } = \frac{\text{Range}}{\text{Range} + \text{Approach}} \times 100$$

$$= \frac{10}{10+5} \times 100$$

$$= 66.667\%$$

✓ **Cooling capacity:**

Cooling capacity (Q) = mass flow rate of water
 × specific heat × temperature difference in kcal/hr
 $= 14166(m^3/hr) \times 4.2(kj/kg) \times 10$
 $= 39.6648 \text{ kcal/sec}$

✓ **Evaporation loss:**

Evaporation losses in $m^3/hr = 0.0085 \times 1.8 \times$
 circulation rate(m^3/hr) $\times (T_1 - T_2)$
 $= 0.0085 \times 1.8 \times 14166 \times 10$
 $= 216.7398 \text{ m}^3/hr$

Percentage of evaporation = $\frac{216.7398}{14166}$
 $= 1.53\%$

✓ **Cycles of Concentrations (COC) :**

$$COC = \frac{\text{Dissolved solids in circulating water}}{\text{Dissolved solids in makeup water}}$$

$$= \frac{330}{40}$$

$$COC = 8.25$$

✓ **Blow down losses:**

Blow down = $\frac{\text{Evaporation loss}}{(COC - 1)}$
 $= \frac{216.7398}{(8.25 - 1)}$
 $= 29.895144 \text{ m}^3/hr$

✓ **Make-up water required:**

Total losses in circulating water = Evaporation losses + Blow
 down losses + Drift losses
 $= 216.7398 + 29.895144 + 2.8332$
 $= 41.578 \text{ m}^3/hr \text{ per cell}$

✓ **Liquid/Gas (L/G) ratio:**

$$L(T_1 - T_2) = G(h_3 - h_1)$$

$$\frac{L}{G} = \frac{(h_3 - h_1)}{(T_1 - T_2)}$$

Where:

L/G = liquid to gas mass flow ratio (kg/kg)

T₁ = hot water temperature (°C)

T₂ = cold water temperature (°C)

h₃ = enthalpy of air water vapour mixture at exhaust wet-
 bulb temperature (i.e at 37°C) from steam table in kcal/kg =
 $(C_p \times T_{3wb} + W_3 \times h_{v3wb})$

Specific humidity of leaving air w₃:

Vapour pressure of the leaving air P_{v3}

$$P_{v3} = (P_{vsat})_{wb} - \frac{[P - (P_{vsat})_{wb}] \times [DBT - WB T] \times 1.8}{2854 - 1.325 [(1.8 \times DBT) + 32]}$$

$$P_{vsat} \text{ at } 37^\circ \text{C WBT} = 0.06282 \text{ bar}$$

$$= 0.06282 - \frac{[1.0132 - 0.06282] \times [40 - 37] \times 1.8}{2854 - 1.325 [(1.8 \times 37) + 32]}$$

$$= 0.06093 \text{ bar}$$

Absolute humidity of leaving air w₃

$$w_3 = 0.622 \times \frac{0.06093}{1.0132 - 0.06093}$$

$$= 0.039801 \text{ kg/kg of dry air}$$

$$h_3 = (C_p \times T_{3wb} + W_3 \times h_{v3wb})$$

$$= (1.005 \times 37 + 0.039801 \times 2568.14)$$

$$= 33.295 \text{ kcal/kg}$$

h₁ = enthalpy of air water vapour mixture at inlet wet-bulb
 temperature (i.e at 27°C) from steam table in kcal/kg = (C_p
 $\times T_{1wb} + W_1 \times h_{v1wb})$

Specific humidity of entering air w₁:

Vapour pressure of the entering air P_{v3}

$$P_{v1} = (P_{vsat})_{wb} - \frac{[P - (P_{vsat})_{wb}] \times [DBT - WB T] \times 1.8}{2854 - 1.325 [(1.8 \times DBT) + 32]}$$

$$P_{vsat} \text{ at } 27^\circ \text{C WBT} = 0.0356811 \text{ bar}$$

$$= 0.03505 - \frac{[1.0132 - 0.0356811] \times [32 - 27] \times 1.8}{2854 - 1.325 [(1.8 \times 32) + 32]}$$

$$= 0.032464 \text{ bar}$$

Absolute humidity of entering air w₁

$$W_1 = 0.622 \times \frac{0.032464}{1.0132 - 0.032464}$$

$$= 0.02 \text{ kg/kg of dry air}$$

$$h_1 = (C_p \times T_{1wb} + W_1 \times h_{v1wb})$$

$$= (1.005 \times 27 + 0.02 \times 2549.58)$$

$$= 18.5882 \text{ kcal/kg}$$

$$\frac{L}{G} = \frac{(h_3 - h_1)}{(T_1 - T_2)}$$

$$\frac{L}{G} = \frac{(33.295 - 18.5882)}{(42 - 32)}$$

$$\frac{L}{G} = 1.4006$$

10. CONCLUSION

For a rectangular cooling tower stack, the model effectively predicts the air and water outlet temperature, fan control prerequisites, cosmetics water necessities, and gulf air and water mass stream rate. Increment in wet knob temperature of gulf air causes increment in air and water outlet temperature and lessening in the vanishing misfortunes. The execution parameters like range, approach, cooling limit, vanishing misfortune, fluid to gas proportion have been assessed when the plant is worked at full load. This check was led with information of incited draft counter stream cooling tower in hostage control plant.

REFERENCES

- 1) M.V.H.Satish Kumar, "Performance Analysis of Cooling Tower" International Journal of Engineering Trends and Technology (IJETT) – Volume 38 Number 9- August 2016.
- 2) Krishna S. Vishwakarma¹, Arpit S.Bhoyar, Saahil K. Larokar, Vaibhav V. Hote and Saurabh Bhudhbaware, "Study the factors on which efficiency of cooling tower can be critically acclaimed" International Journal of Engineering Research and Applications ISSN : 2248-9622, Vol. 5, Issue 4, (Part -3) April 2015.
- 3) Gaurav Aggarwal, s s Kachhwaha and R S Mishra, "Parametric study if induced draft counter flow rectangular cooling tower based on exergy analysis" Journal of scientific and Industrial research vol.69, Reccieved 20 May 2009; revised 19 Jan 2010; accepted 27 January 2010.
- 4) Pooja Rai and Irshad Ahmad Khan, " Performance analysis of cooling tower" 4th international conference on recent trends in Engineering science and management, the international center Goa, 7th August 2016.
- 5) Xiao Li, Yaoyu Li and John E. Seem, "Dynamic Modeling of Mechanical Draft Counter-Flow Wet Cooling Tower" International Refrigeration and Air Conditioning Conference 2010.
- 6) S. Jothibasu. "Energy efficiency improvement in cooling tower of thermal power plant" Central Power Research Institute, P.B. no. 8066, Sadashivanagar, Bangalore.