

A Novel Multi level Converter Unified Power – Quality (MC-UPQC) Conditioning System On line Loading, Losses , And Voltage Stability Of Radial Distribution Systems

Shaik Azharuddin¹, B Venkata Ramana²

¹ PG Student , Dept of EEE , Thandrapaparaya Institute of Science & Techonology,AP,India

²Assistant Professor , Dept of EEE , Thandrapaparaya Institute of Science & Techonology,AP,India

Abstract – This Project Presents a new unified power quality Conditioning System (MC – UP QC) , Capable of Simultaneous compensation for voltage and current in multi-bus/multi-feeder systems. In this Configuration, One Shunt Voltage – Source Converter (Shunt VSC) and two or more serices VSCs exist. Therefore, Power can be Transformed from one feeder to adjacent feeders to companste for sag/swell and interruption. The proposed topology can be used for simultaneous compensation of voltage and current imperfections in both feeders by sharing power compensation capabilities between two adjacent feeders which are not connected. The simulation results show that a significant amount of power-loss reduction, under voltage mitigation, and the enhancement of voltage stability margin can be obtained with an appropriate placement of the MC-UPQC in a distribution network. The performance comparison of the MC-UPQC with one previously reported design approach shows that it is more efficient in under voltage mitigation.

Key Words : Multi Level Converter , Unified Power-Quality, Voltage Stability

1.INTRODUCTION

In recent years, Power engineers are increasingly concerned over the quality of the electrical power. In modern industries, load equipment uses electronic controllers which are sensitive to poor voltage quality and will shut down if the supply voltage is depressed and may mal- operate in other ways if harmonic Distortion of the supply voltage is excessive. Most of this modern load equipment uses electronic switching devices which can contribute to poor network voltage quality. The competition in electrical energy supply has created greater commercial awareness of the issues of power quality while equipment is readily available to measure the quality of the voltage waveform and so quantify the problem. The FACTS devices and Custom power devices are introduced to electrical system to improve the power quality of the electrical power. DVR, DSTATCOM, ACTIVE FILTERS, UPQC etc are some of the devices used to improve the power quality of the voltage and current. With the help of these devices we are capable to reduce the problems related to power quality.

Although all devices can improve the power quality but in this the focus is on UPQC. UPQC is a power electronic device consisting of both DVR and D-STATCOM, former is connected in series and latter is connected in parallel to protect the sensitive load from all disturbances.

1.1 Scope of Work

This dissertation proposes the MATLAB SIMULINK model of unified power quality conditioner which is used for the improvement of power quality at distribution level. The major objectives are summarized as follows: Study the model of UPQC. Investigating the performance of Unified Power Quality Conditioner (UPQC) using the proportional integral control in distribution systems.

1.2 Definition of Power Quality

Power quality has different meanings to different people. Institute of Electrical. All electrical devices are prone to failure or malfunction when exposed to one or more power quality problems. The main reasons for concern with power quality (PQ) are as following: End user devices become more sensitive to PQ due to many microprocessor based controls. Continuous development of high performance equipment: Such equipment is more susceptible to power disturbances. The realization of quality electrical power is the responsibility of the suppliers and users of electricity. Suppliers are in the business of selling electricity to widely varying client. The need of one user is usually not the same as the needs of other users. Most electrical equipment is designed to operate within a voltage of $\pm 5\%$ of nominal with marginal decrease in performance.

2. Responsibilities of the suppliers and users of electrical power

The realization of quality electrical power is the responsibility of the suppliers and users of electricity. Suppliers are in the business of selling electricity to widely varying client. The need of one user is usually not the same as the needs of other users. Most electrical equipment is designed to operate within a voltage of $\pm 5\%$ of nominal with marginal decrease in performance. For the most part,

utilities are committed to adhering to these limits. At locations remote from substations supplying power from small generating stations, voltages outside of the $\pm 5\%$ limit are occasionally seen. Such variation could have a negative impact on loads such as motors and fluorescent lighting. The overall effects of voltage outside the nominal are not that significant unless the voltage approaches the limits of $\pm 10\%$ of nominal. Also, in urban areas, the utility frequencies are rarely outside ± 0.1 Hz of the nominal frequency. This is well within the operating tolerance of most sensitive. This is resulting in increasing harmonic level on power systems and has many people concerned about the future impact on system capabilities. End users have an increased awareness of power quality issues. Utility customers are becoming better informed about such issues as interruptions, sags, and switching transients and are challenging the utilities to improve the quality of power delivered.

increased overall power system efficiency resulted in continued growth of devices such as high-efficiency adjustable-speed motor drives and shunt capacitors for power factor correction to reduce losses. This is resulting in increasing harmonic level on power systems and has many people concerned about the future impact on system capabilities. End users have an increased awareness of power quality issues. Utility customers are becoming better informed about such issues as interruptions, sags, and switching transients and are challenging the utilities to improve the quality of power delivered.

Table -1:

In de ripti x	Desc ription	Examples
Power Quality Indices		
I	Low power quality problems	Service entrances switchboard, lighting power distribution panel
II	po Mode rate r quality problems	HVAC power panels
III	po we High r quality problems	Panels supplying adjustable speed drives, elevators, large motors

There is an increased concern of power quality due to the following reasons:

New-generation loads that use microprocessor and microcontroller based controls and power electronic devices, are more sensitive to power quality variations than that equipments used in the past. The demand for

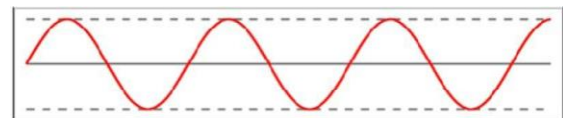

Normal waveform

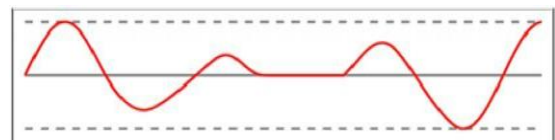

Interruption

Long-duration variations can be categorized as over voltages, under voltages or sustained interruptions.



Voltage Fluctuations or Flicker

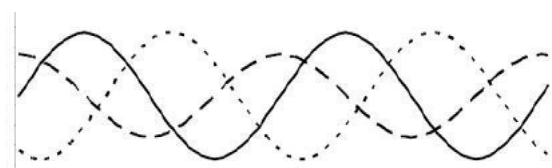

Voltage imbalance

A voltage imbalance is a variation in the amplitudes of three-phase voltages, relative to one another. Voltage imbalance can be the result of different loads on the phases, resulting in different voltage drops through the phase-line impedances. Waveform distortion is defined as a steady-state deviation from an ideal sine wave of power frequency principally characterized by the spectral content of the deviation.

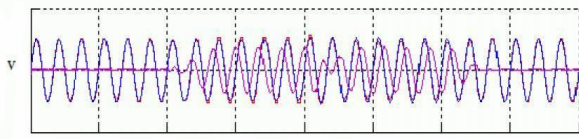

Harmonics

Harmonic distortion levels can be described by the calculating total harmonic distortion (THD) which measures the complete harmonic spectrum with magnitudes and phase angles of each individual harmonic component

The most widely used solution for limitation of the fault currents is to use a transformer with a split secondary winding (or a three windings transformer) and current limiting reactors. The basic configuration of Solid State Current Limiter is shown

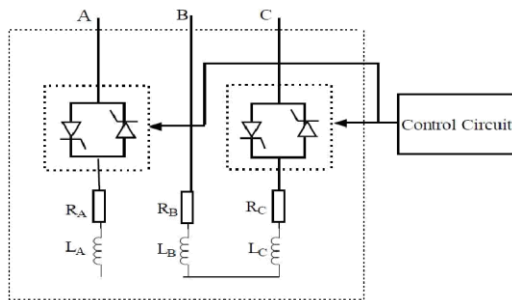

Solid State Current Limiter

The SSTs can be used very effectively to protect sensitive loads against voltage sags, swells and other electrical disturbances. The SSTs provides continuous high-quality power supply to sensitive loads by transferring, within a time scale of milliseconds, the load from a faulted bus to a healthy one.

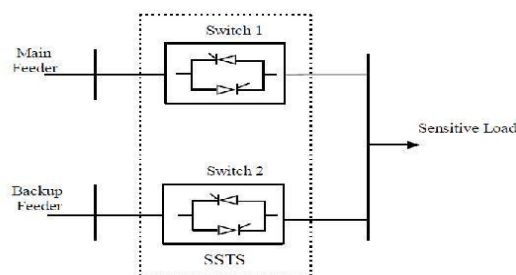

Solid State Transfer Switch

The basic configuration of this device consists of two three-phase solid-state switches, one for the main feeder another for the backup feeder. Each time a fault condition is detected in the main feeder, the control system swaps the firing signals to the thyristors in both switches, i.e., Switch 1 in the main feeder is deactivated

and Switch 2 in the backup feeder is activated. The control system measures the peak value of the voltage waveform at every half cycle and checks whether or not it is within a pre-specified range.

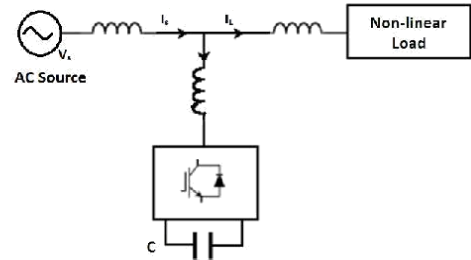

Distribution STATCOM

DVR injects a voltage component in series with the supply voltage, thus compensating voltage sags and swells on the load side. It works as a harmonic isolator to prevent the harmonics in the source voltage reaching the load in addition to balancing the voltages and providing voltage regulation.

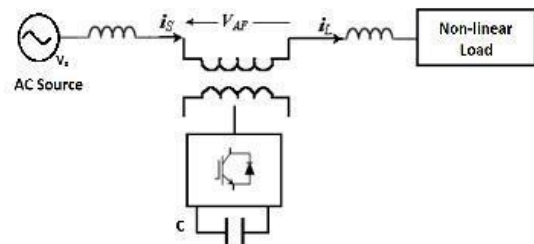

Dynamic Voltage Restorers

The best protection for sensitive loads from sources with inadequate quality, is shunt-series connection i.e. unified power quality conditioner (UPQC). The series compensator is operated in PWM voltage advance controlled mode. It injects voltage in quadrature advance to the supply voltage (current) such that the load end voltage is always maintained at the desired value. The two inverters operate in a coordinated manner.

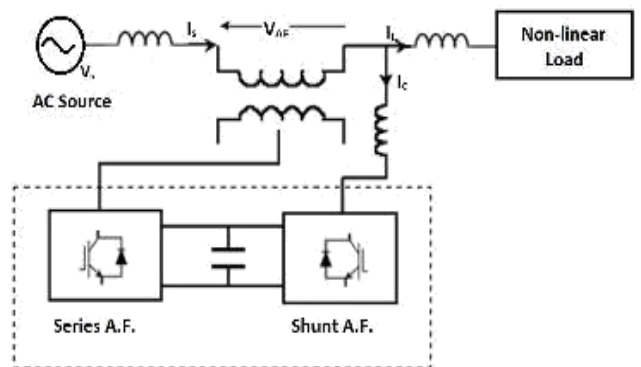

Unified Power Quality Conditioner (UPQC)

Each of Custom Power devices has its own benefits and limitations. The UPQC is expected to be one of the most powerful solutions to large capacity loads sensitive to supply voltage and load current disturbances /imbalance. The most effective type of these devices is considered to be the Unified Power Quality Conditioner (UPQC). There are numerous reasons why the UPQC is preferred over the others. UPQC is much flexible than any single inverter based device. It can simultaneously correct for the unbalance and distortion in the source voltage and load current where as all other devices either correct current or voltage distortion. Therefore the purpose of two devices is served by UPQC only.

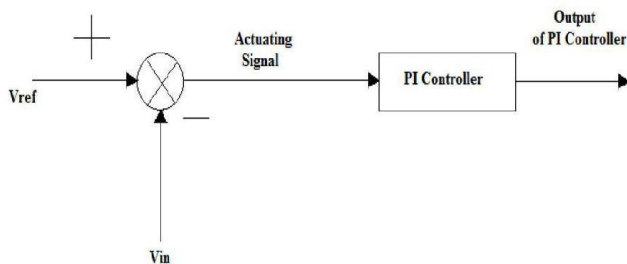

PI controller

A PI-Lead controller is a proportional gain in parallel with an integrator; both in series with a lead controller. The proportional gain provides fast error response. The integrator drives the system to a steady-state error. PI controller is one of the most widely sought after controller in industry as it is the simplest to design.

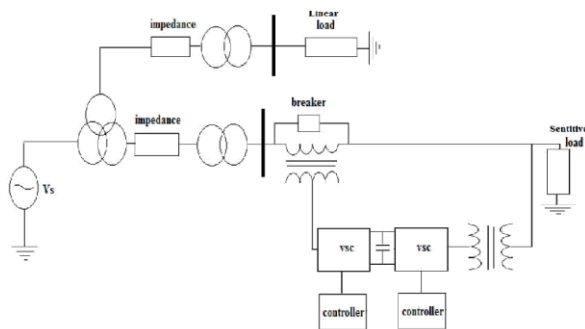

Circuit Model of UPQC Test System

In this system, the generating unit with a test system employed to carry out the simulations concerning the UPQC Actuation. The output from generating unit is fed to the primary of the three winding transformer. Further two parallel feeders of 11KV each are drawn

In this work, the role of Unified power quality conditioner for power quality improvement in distribution network having adjustable speed drive load i.e. field oriented induction motor.

Distribution network having field oriented control induction motor as load during fault conditions.

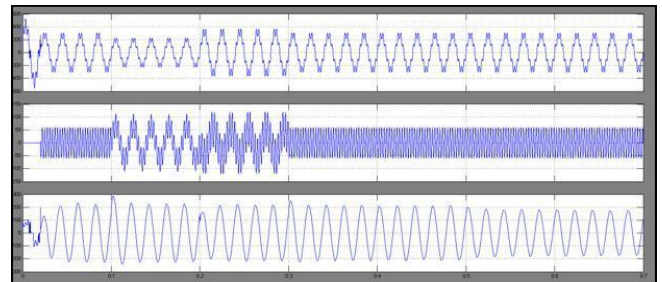

Simulation results for an upstream fault on Feeder2: BUS2 voltage, compensating voltage, and loads L1 and L2 voltages.

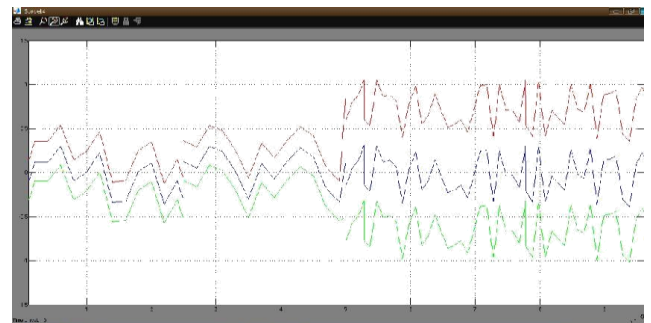

Phase Voltage during sag condition

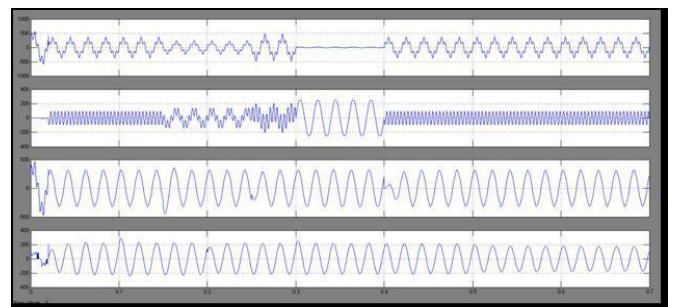

Nonlinear load current, compensating current, Feeder1 current, and capacitor voltage.

3. CONCLUSIONS

In the project, the main objectives for the utilization of the studied equipment have been to reducing the distortion level occurring in the cases of harmonics generating loads in distribution networks and highly improving the power quality of the system. The MATLAB/SIMULINK were used to carry out extensive simulation studies on unified power quality conditioner and for the controlling purpose the proportional integral controller is used and adjustable speed drive is used as a load. Therefore, UPQC is considered to be an efficient solution. Unified power quality conditioner is capable of

reducing the level of THD in the case of networks which are connected to the harmonics generating load (like ASD). All type of faults (single line to ground, double line to ground, three phase line to ground fault are also compensated using UPQC.

ACKNOWLEDGEMENT

It is my sincere obligation to thank my guide Mr. B.Venkata Ramana, Asst.professor for his immeasurable beneficent help, with timely suggestions, insurmountable guidance & constant encouragement given for me I express my gratitude to the Principal Mr. Joshua Jai Prasad, for providing necessary co-operation to me

REFERENCES

- [1] Impact of Unified Power - Quality Conditioner allocation on line Loading, Losses , and Volage Stability of Radial distribution Systems Sanjib Ganguly , Mmember , IEEE
- [2] M.Rastogi ,R.Naik , and N.Mohan , "A" comparative evaluation of harmonic reduction techiques in three phase utility interface of power electrnic loads, "IEEE Trans . Ind . Appl , Vol . 30 , no.5,pp.1149-1155,Sep./Oct 1994.
- [3] F.Z.Peng , " Application issues of active power filters ", IEEE Ind . Appl.Mag. , Vol.4, no.5, pp.21-30,Sep./Oct. 1998.
- [4] H.Akagi , "New trends in active filters for power conditioning"EEETrans.Ind.Appl.,Vol.32,no.6,pp.1 3112-1322,Nov./Dec.1996.
- [5] C.Sankaran, " Power Quality" , CRC Press LLC, 2002.

BIOGRAPHIES



Shaik Azharuddin
P G Student,
Department of EEE,
Thandrapaparaya Institute
of Science and Teconology ,
Komatapalli,Bobbili.



B Venkata Ramana
Assistant Professor
Department of EEE,
Thandrapaparaya Institute
Of Science and Teconology,
Komatapalli , Bobbili.