

# Design And Finite Element Analysis Of Fixture For Milling Of Cummins Engine Block

Shrihari Bukkebag<sup>1</sup>, Dr. S.R. Basavaraddi<sup>2</sup>

<sup>1</sup>PG Scholar, Dept. of Mechanical Engineering KLE Dr MSSCET, Belagavi

<sup>2</sup>Profesor, Dept. of Mechanical Engineering KLE Dr MSSCET, Belagavi

\*\*\*

**Abstract** - One of the critical elements involved in mass a production facility is Fixture. Fixtures are used in machining components with high accuracy and efficiency. The aim of this project is to design a milling fixture to mill the top surface of the B-6 Cummins Engine block to a depth of 1 millimeter with a cycle time less than 3 minutes and meet the production target of 400 units per day. Hydraulic elements are also used in the fixture to make the process more efficient and to achieve the given targets. The fixture is also tested for its design feasibility by performing static analysis on ANSYS.

**Key Words:** Fixture, Milling, Cycle time, Static Analysis, Engine Block.

## 1. INTRODUCTION

The jigs and fixtures are the economical ways to produce a component in mass. So jigs and fixtures serve as one of the most important means of mass production system. These are special work holding and tool guiding device. Quality of the performance of a process is largely influenced by the quality of jigs and fixtures used for this purpose. What makes a fixture unique is that each one is built to fit a particular part or shape. The main purpose of a fixture is to locate and in the cases hold a workpiece during an operation.

### 1.1 Background of the Problem

A six cylinder Cummins engine block is cast in grey cast iron with all the necessary locating points to mount the engine over a fixture. The major requirement of this project is to design and fabricate a milling fixture for milling of the top face of B-6 Cummins Engine block to a depth of 1 millimeter over a bed type milling machine with a cycle time less than 3 minutes and meet the production targets of 400 units per day.

### 1.2 Methodology

The steps involved in designing this fixture include 1. Fixing the Constraints 2. Fixing the dimensions of the fixture based on the dimensions of the engine 3. Building solid 3D model 4. Carrying out Finite Element Analysis on ANSYS to find out the Stress 5. Calculating the results theoretically 6. Comparison of results.

## 2. LIRATURE REVIEW

**K.Srinivasulu et al [1]** in his work based on design of machining fixture for turbine rotor blades discusses about his work based on the industry requirement for machining the turbine blade on a vertical machining centre (VMC). Fixture Design consists of High product rate, low manufacturing operation cost. The fixture was to be designed in such-away that part/product change overtime is very less.

**Victor Songmene et al [2]** published his experimental results of Analytical modelling of slot milling exit burr size. In this work, a computational modelling algorithm was proposed to predict the radial and tangential cutting forces ( $F_r$ ,  $F_t$ ), friction angle  $\lambda$  and burr thickness  $B_t$  in slot milling of ductile materials. A new force model, so-called "mechanistic approach" that comprises an algorithm for simultaneous calculation of average cutting forces, chip thickness and cutting force coefficients  $K$  was then used to build new computational modelling algorithm.

**S. S. Mohite & M. A. Sutar et al [3]** Their work establishes the FEA model of fixture unit assembly to predict fixture unit stiffness and FEA model of rough surface contact to predict contact stiffness. Based on this study the appropriate boundary conditions were derived, the type of elements to be employed and the degree of meshing to be produced were also considered.

**Shailesh S Pachbhai & Laukik P Raut et al [4]** This paper discusses in detail the steps involved in designing a hydraulic clamp it also discusses in length the time taken to machine the same component on a manual fixture and compares it with the time taken on a hydraulic fixture and the amount of time saved leading to an increase in production of the component it also takes into account the cost savings given that the ideal time of the machine is reduced. The hydraulic fixture also improves repeatability and also reduces workpiece distortion.

## 3. DESIGN OVERVIEW

The dimensions of the fixture were finalized based upon the dimensions of the engine and the saddle.



#### 4. CALCULATIONS

##### Design parameters

Power of Motor = 10 hp = 7.5 KW  
 Speed of milling cutter = 145 rpm  
 Dia. of cutter  $D_c = 315$  mm  
 Depth of cut  $a_p = 1$  mm  
 Table Feed  $V_f = 428.62$  mm/min  
 No. of Teeth  $z = 24$

##### Cutting Speed $V_c$ [5]

$V_c = \pi D_n / 1000$   
 $V_c = \pi * 315 * 145 / 1000$   
 $V_c = 143.49$  m/min

##### Feed rate per tooth $F_z$

$F_z = V_f / Z * n$   
 $F_z = 428.62 / 24 * 125$   
 $F_z = 0.123$  mm/tooth

##### Power $P_c$

$P_c = K_c * a_p * a_e * V_f / 60 * 10^6$   
 $P_c = 1750 * 1 * 252 * 429 / 60 * 10^6$   
 $P_c = 3.15$  KW

##### Torque $M_c$

$M_c = P_c * 30 * 10^{-3} / \pi n$   
 $M_c = 3.15 * 30 * 10^{-3} / \pi * 140$   
 $M_c = 214,859.17$  N-mm

##### Force $F$

$F = M_c / r$   
 $F = 214,859.17 / 157.5$   
 $F = 1364.18$  N

#### 4.1 Calculating Stress on Pin 1 & 2

A double Shear Stress is acting on the Pins as illustrated in the figure 4.1 below, a force of 1364.18 N is acting on the centre of the pin and both the ends are fixed. Material used is mild steel with Yield Strength of 250 Mpa.

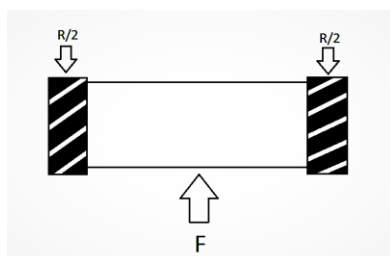

Fig -4.1: Double Shear on pins

#### Calculating stress on pin 1 [6]

$\tau_1 = F / 2A$   
 $\tau_1 = F / 2 * (\pi / 4 * d^2)$

$\tau_1 = 1364.18 / 2 * (\pi / 4 * 12^2)$   
 $\tau_1 = 6.03$  Mpa

#### Calculating stress on pin 2 [6]

$\tau_2 = F / 2A$   
 $\tau_2 = F / 2 * (\pi / 4 * d^2)$   
 $\tau_2 = 1364.18 / 2 * (\pi / 4 * 10^2)$   
 $\tau_2 = 8.68$  Mpa

#### 4.2 Design of bolt

##### Allowable upper limit of force [7]

$F = \sigma * A_s$   
 Where  $A_s$  is the stress area of the bolt which is 58 mm<sup>2</sup>  
 $F = 420 * 58$   
 $F = 24360$  N

##### Initial Tightening load

$F = 1400 * d_o$   
 Where,  $d_o$  = outer diameter of bolt = 10 mm  
 $F = 1400 * 10$   
 $F = 14000$  N

##### Tightening torque

$T = c * d * F_i$   
 where,  $c = 0.15$  coefficient of friction  
 $T = 0.15 * 10 * 1400$

##### Tensile stress on bolt

$\sigma = F / A$   
 $\sigma = 16800 / 113.1$   
 $\sigma = 148.54$  Mpa

##### Torsional Shear Stress

$\tau = 16 * T / \pi * d_c^3$   
 $\tau = 16 * 21000 / \pi * 9.0257^3 * 4$  (No. of bolts = 4)  
 $\tau = 36.36$  Mpa

##### Factor of safety

FOS = Yield Strength / Allowable Strength  
 $FOS = 310 / 36.36$   
 $FOS = 8.4$

#### 4.3 Clamping Pressure

The Clamping Cylinder has an operating pressure range of 1 Mpa to 7 Mpa, which translates to a clamping force of range 1809 N to 12666 N, by operating the cylinder at 1.2 Mpa we have a Clamping Force of 2714 N, which is approximately 1.5 times the force exerted by the milling cutter. [8]

#### 4.4 Table of values

Table -4.1: Table of values

| SL.No | PARAMETERS                      | VALUES          |
|-------|---------------------------------|-----------------|
| 1     | Torque of Milling Cutter        | 214,859.17 N-mm |
| 2     | Force exerted by Milling Cutter | 1364.18 N       |
| 3     | Tightening torque on Bolt       | 21000 N-mm      |
| 4     | Tensile stress on Bolt          | 148.54 Mpa      |
| 5     | Torsional Shear stress on Bolt  | 372.06 Mpa      |

#### 5.SOLID MODELLING

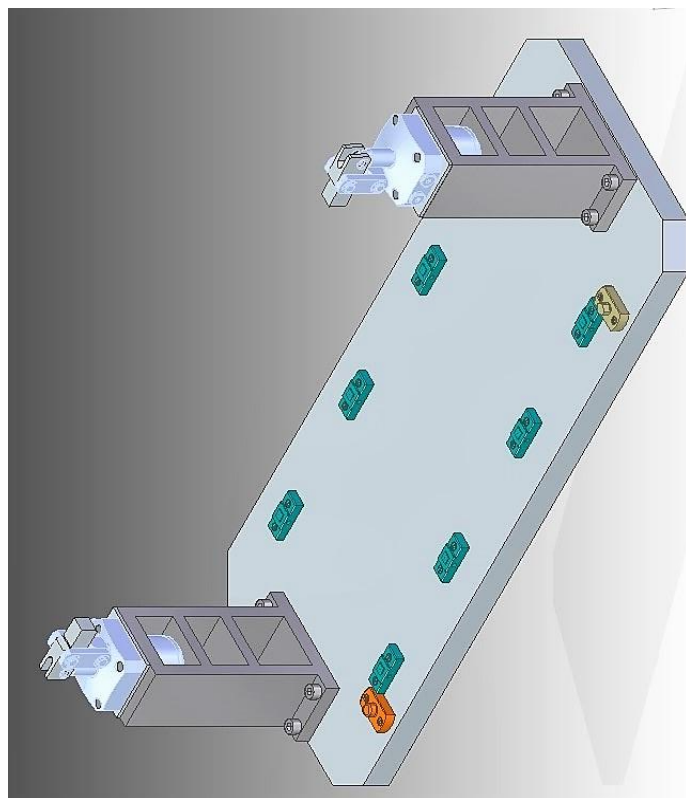

Fig -5.1: Assembled fixture

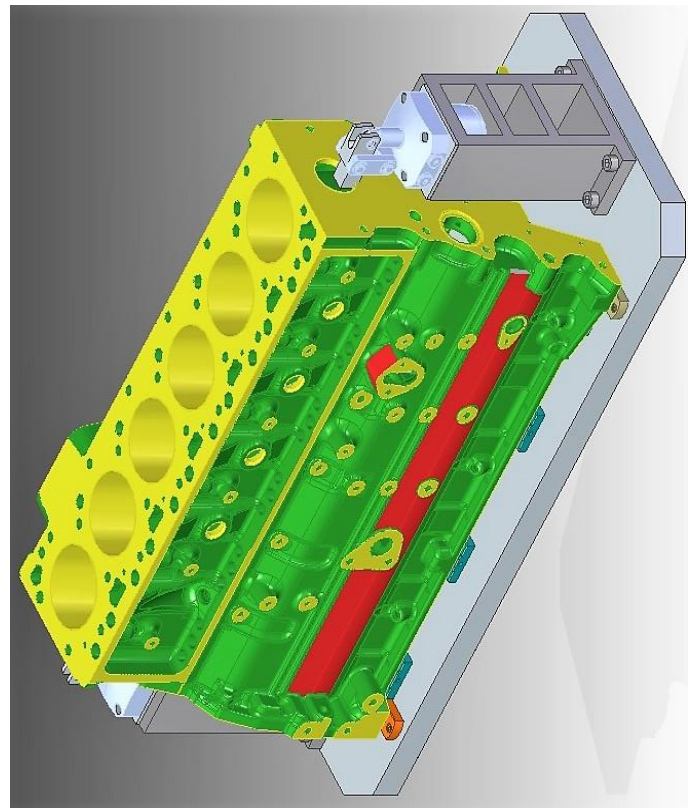

Fig -5.2: Assembled fixture with engine block

#### 6. FEM RESULTS AND DISCUSSIONS

Figure 6.1 shows equivalent Von-Mises stress of 45.31 Mpa acting on Clamp Strap.

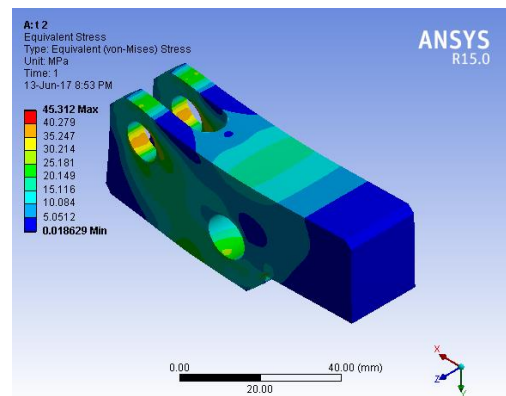

Fig -6.1: Von-Mises Stress acting on Clamp Strap

Figure 6.2 shows maximum principal stress of 60.65 Mpa acting on the Clamp Strap.



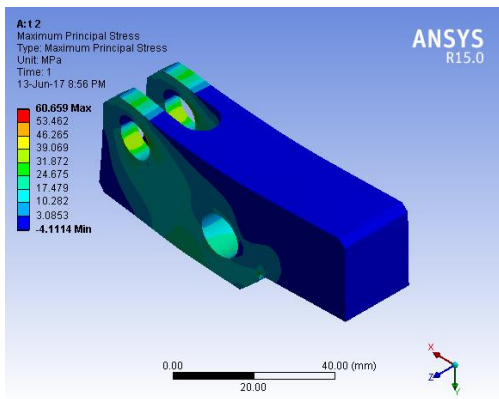

Fig -6.2: Max Principal stress acting on Clamp Strap

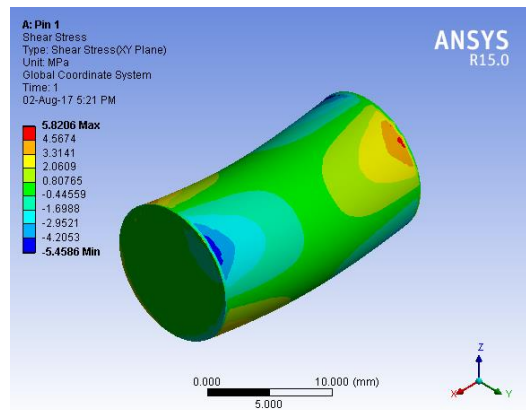

Fig -6.5: Shear Stress acting on pin 1

Figure 6.3 shows equivalent Von-Mises stress of 87.44 Mpa acting on Height Bracket.

Figure 6.6 shows the equivalent von mises stress of 44.80 Mpa acting on Pin 1.

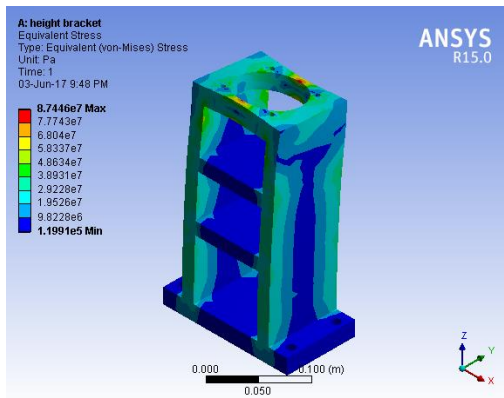

Fig -6.3: Von-Mises Stress acting on Height Bracket

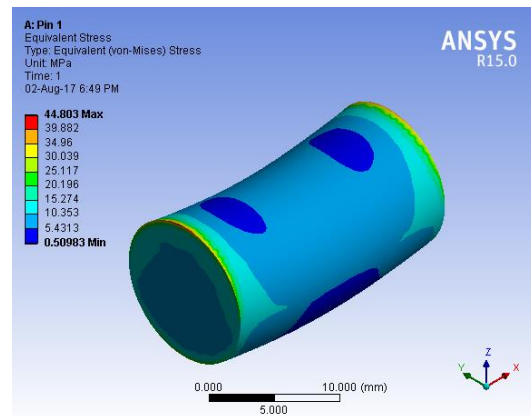

Fig -6.6: Von Mises Stress on Pin 1

Figure 6.4 shows maximum principal stress of 88.96 Mpa acting on the Height Bracket.

Figure 6.7 shows Shear stress of 7.13 Mpa acting on Pin 2

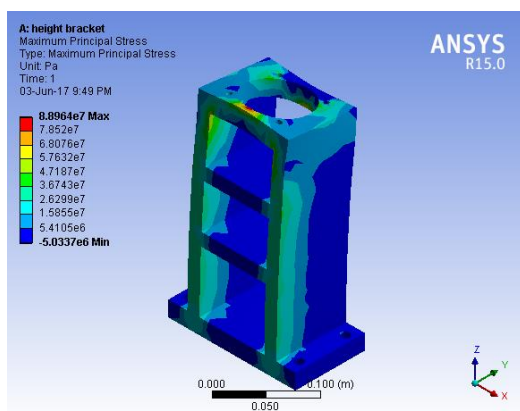

Fig -6.4: Max Principal stress acting on Height Bracket

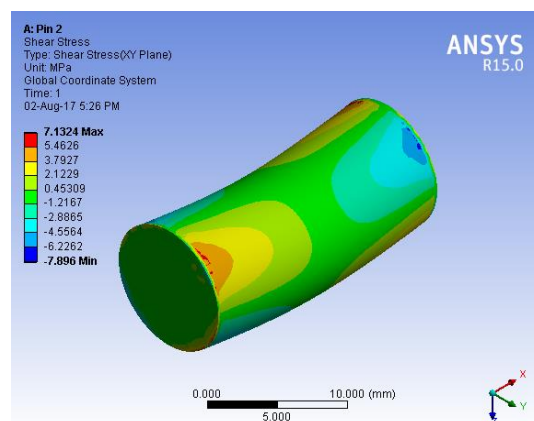

Fig -6.7: Shear Stress acting on pin 2

Figure 6.5 shows shear stress of 5.82 Mpa acting on Pin 1.

Figure 6.8 shows Equivalent Von Mises stress of 93.55 Mpa acting on Pin 2

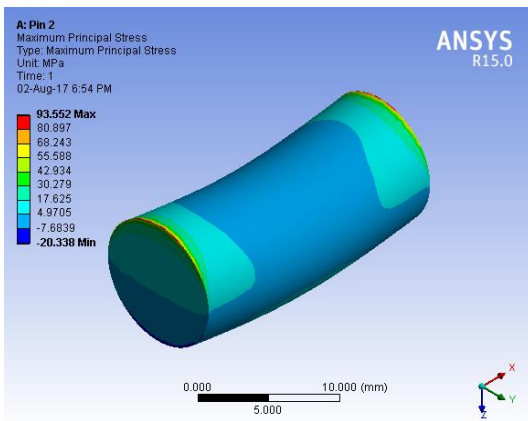

Fig -6.8: Von Mises stress on Pin 2

Figure 6.9 shows equivalent Von-Mises stress of 13.01 Mpa acting on round head pin.

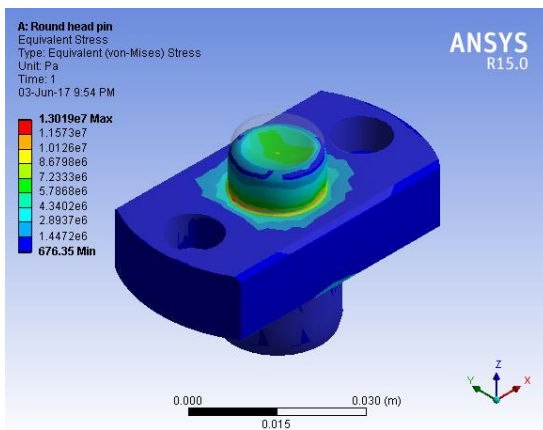

Fig -6.9: Von-Mises Stress acting on Round Head pin

Figure 6.10 shows maximum principal stress of 2.55 Mpa acting on the round head pin.

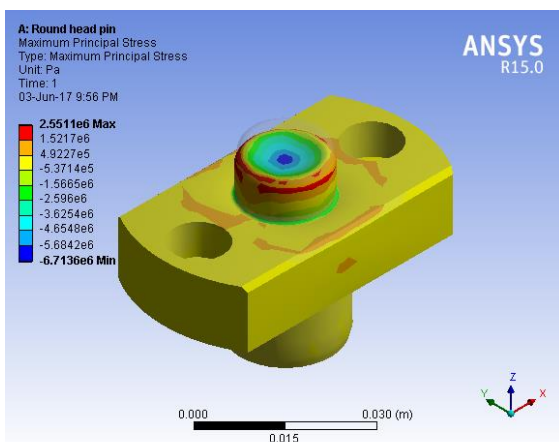

Fig -6.10: Max Principal stress acting on Round Head pin

Figure 6.11 shows equivalent Von-Mises stress of 11.93 Mpa acting on diamond head pin.

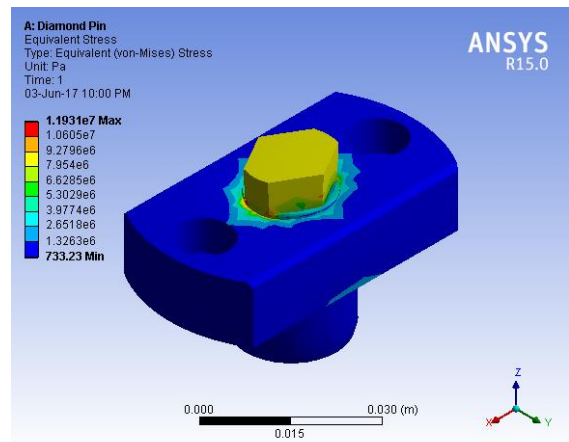

Fig -6.11: Von-Mises Stress acting on Diamond Head pin

Figure 6.12 shows maximum principal stress of 6.79 Mpa acting on the diamond head pin.

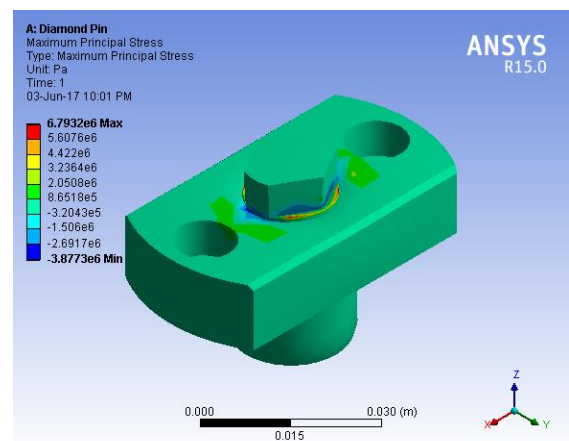

Fig -6.12: Max Principal stress acting on Diamond Head pin

## 6.1 Discussions

**Clamp Strap:** as shown in figure 6.1 & 6.2 is made of Mild Steel with an yield strength of 250 MPa, the equivalent Von-Mises stress of 45.31 Mpa is acting on it and maximum principal stress of 60.65 Mpa acting on the Clamp Strap. The type of element used is Triangular element total no. of nodes 113671 and total no. of elements are 66029.

**Height Bracket:** as shown in figure 6.3 & 6.4 is made of Steel with an yield strength of 250 MPa, equivalent Von-Mises stress of 87.44 Mpa is acting on the bracket and maximum principal stress of 88.96 Mpa is acting on the Height Bracket. The type of element used is Triangular element total no. of nodes 5609 and total no. of elements are 2889.

**Pins:** as shown in figures 6.5 to 6.8 are made of Hardened Steel with an yield strength of 270 Mpa. Shear Stress and Von Mises Stress acting on pin 1 are 5.82 Mpa and 44.80 Mpa respectively. Shear Stress and Von Mises Stress acting on pin 2 are 7.13 Mpa and 93.55 Mpa respectively. The total no. of nodes on pin 1 are 62445 and total no. of elements are 30884 and the total no. of nodes on pin 2 are 56572 and total no. of elements are 27883. The type of element used is rectangular element.

**Round Head Pin :** as shown in figure 6.9 & 6.10 is made of En-31 with an yield strength of 450 Mpa and case hardened, equivalent Von-Mises stress of 13.01 Mpa acting on round head pin and maximum principal stress of 2.55 Mpa acting on it. The type of element used is Triangular element total no. of nodes 3374 and total no. of elements are 1837.

**Diamond Head Pin :** as shown in figure 6.11 & 6.12 is made of En-31 with an yield strength of 450 Mpa and case hardened, equivalent Von-Mises stress of 11.93 Mpa acting on round head pin and maximum principal stress of 6.79 Mpa acting on it. Type of element used is Triangular element total no. of nodes 3354 and total no. of elements are 1820. For all the Critical Parts that have been analyzed its has been found that the stresses acting on them are well below the Yield Strength Limits of the materials used hence we can say that the design is feasible.

## 7. RESULTS

### Machining Time

Table -7.1: Machining Time

| No of Trials | Machining Time (Mins.) |
|--------------|------------------------|
| 1            | 2.56                   |
| 2            | 2.52                   |
| 3            | 2.54                   |
| 4            | 2.58                   |
| 5            | 2.53                   |

### Comparison of Theoretical Calculations with FEM Results

Table -7.2: Comparison of results

| Parameters            | Theoretical Values Mpa | Analytical Values Mpa | Remarks |
|-----------------------|------------------------|-----------------------|---------|
| Shear Stress on Pin 1 | 6.03                   | 5.82                  | Safe    |
| Shear Stress on Pin 2 | 8.68                   | 7.13                  | Safe    |

## 8. CONCLUSION

- The Fixture has been effectively designed for the given problem, the critical components have been analytically tested in Static Analysis, the results of these tests fall well below the yield strength limits of the materials used, rendering the design feasible.
- The dowel pins and rest pads have been case hardened to provide extra robustness for heavy duty mass production.
- Pneumatic sensors have been incorporated into the rest pads to provide feedback to the operator as to whether the engine has been clamped properly or not before the operation begins this will ensure that the component is aligned properly and also help avoid machining errors.
- The average machining time of the engine with the fixture is 2.54 Minutes. On an average this fixture machines around 400 engines per day.

## REFERENCES

- [1] C.Radha Madhavi, B. Ramu, K. Srinivasulu "Design of Machine Fixture for Turbine Rotor Blade", International Journal of research in engineering and technology eISSN: 2319-1163, pISSN: 2321-7308.
- [2] Seyed Ali Niknam & Victor Songmene, "Analytical modelling of slot milling exit burr size", Springer-Verlag London 2014.
- [3] S. S. Mohite & M. A. Sutar, "Finite Element Modelling And Analysis Of Workpiece-Fixture System", Dept. of Mechanical Engineering, Govt. College of Engineering, Karad, Dist- Satara, Maharashtra, India.
- [4] Shailesh S Pachbhai1 and Laukik P Raut, "Design And Development Of Hydraulic Fixture For Machining Hydraulic Lift Housing", ISSN 2278 - 0149 Vol. 3, No. 3, July, 2014.
- [5] Tungaloy cutting tools "Technical Reference".
- [6] Balveer Reddy "Engineering Data Handbook".
- [7] Standard Handbook of Machine Design 3ed - Shigley, Mischke.
- [8] CLASP Product Manual.