

A Multilevel Inverter With MPPT Control For Drifting Analysis And Improved Power Quality

CHOUDHARY YUGANDHARA SURESH¹, DR. B. R. PATIL², SHARVARI SANE³

¹Lecturer, SESGOIFE, Diksal, Raigad, India,

²Principal, Vishwaniketan IMEET, Khalapur, Raigad, India.

³Assistant Professor, Dilkap College of Engineering, Neral, Raigad, India.

Abstract - Maximum power point tracking (MPPT) algorithmic program with a single output voltage sensor for (PV) system is given in this paper. The MPPT algorithmic program is developed by considering the slope (dV_o-dD) of $V_o - D$ characteristics. In this technique solely a resistor circuit is employed to sense the converter output voltage (V_o). The steady state behavior, tracking performance for a modification in insolation and for a load variation with the output voltage sensor primarily based MPPT algorithmic program are addressed through experimental results to see the tracking efficiency. The duty cycle is generated directly without using any proportional-integral control loop to simplify the control circuit. This method is used for fast tracking. However every so often in steady state it suggests low oscillation in MPP. In this paper drift analysis and steady state behavior also are given to see the tracking efficiency. We build the simulation by using MATLAB.

Key Words: Multilevel Inverter, Maximum Power Point Tracking, Adaptive, Drift Phenomena, Steady State .

1. INTRODUCTION

The elevated electricity demand and absence of fossil reserves encouraged researchers to recognition on renewable power resources. A number of the current renewable power assets photovoltaic strength generation is evolving as one of the most awesome renewable energy supply because of its benefits which include ecofriendly nature, much less maintenance and no noise. The $i - v$ traits of a PV module will vary with solar insolation and atmospheric temperature [1], [2]. Performance of the PV system typically relies upon on the operating point on the function curve of the PV module. Most power factor (MPP) exists for a PV module where in the output strength from the module is maximum. Thus far a big number of maximum strength point tracking (MPPT) strategies had been developed to growth the efficiency of the PV system. MPPT algorithms may be categorized specifically into two categories one is input parameter based totally and every other is output parameter based totally. MPPT algorithms along with fractional open circuit voltage [3], fractional short circuit current [4], hill climbing [5], perturb and

observe (P&O) [6]-[8], incremental conductance (InCond) [9], [10], incremental resistance (inr) [8], ripple correlation manage (RCC) [5], techniques have been evolved to extract the maximum electricity from the PV arrays by the use of the input parameter/s either vice chairman V_{pv} (PV module voltage) or I_{pv} (PV module current) or each. The various numerous MPPT techniques, fractional open circuit voltage and quick circuit contemporary strategies provide an easy and powerful way to extract most strength, however they require periodical dimension of open circuit voltage or brief circuit current for reference, inflicting more power loss.

From the literature it is found that P&O and incremental conductance techniques are substantially implemented strategies due to their improved performance and ease of implementation [10]. However with the P&O-like algorithms the working factor actions far from MPP whilst there is a speedy increase in insolation [6]-[9]. The RCC MPPT set of rules calls for the time derivative of the strength converter voltage and contemporary ripples to determine the placement of the working factor on the function curve of the PV module. So for excessive frequency converter it's very tough to acquire the accurate time derivative of the array voltage and current. Different current strategies display improved performance the use of fuzzy logic, neural community, optimization algorithm, sliding mode manage, but they're no longer generally used due to their complexity and want of highly-priced digital processor. Overview of all of the MPPT techniques published recently are very well discussed in [9-10].

The MPPT algorithm also can be implemented via the usage of output parameters inclusive of both V_o (converter output voltage) or I_o (converter output current) depending at the sort of load. In [5] it's mentioned that for a battery load, the available maximum energy can be extracted from the PV module by way of maximizing only the battery current and in [7] the MPPT approach is developed by way of sensing the output contemporary for a battery load. The opportunity of the use of output parameter i.e. both voltage and current to track the MPP is depends on the kind of load and the corresponding analysis is provided in [10]. But in [8], [9]. The tracking performance for an

exchange of insolation and steady state behavior of the MPPT algorithm are not established.

This paper presents a transparent illustration behind the usage of output parameters instead of input parameters for tracking the MPP by exploitation $V_o - D$ and $I_o - D$ characteristics. Most of the sensible PV systems contains battery, wherever the output voltage and current area unit to be measured for the aim of charge management and battery protection. By exploitation only the output parameters, each objectives of MPPT and charge management of battery is achieved which ends in reduction of value of the PV system. Furthermore this MPPT algorithm is economical, simple and strong to load variations. The tracking performance and steady state behavior of the MPPT formula are clearly incontestable through experimental results. Voltage sensor method is validated for the multilevel converter. The main concepts of the any MPPT algorithms are to found the tracking efficiency by using steady state and drift phenomenon. In our paper adaptive method, steady state behavior and drift analysis are address. In this paper we use multilevel inverter which is used to reduce the harmonics in the output voltage. And it will help to improve the PV voltage range.

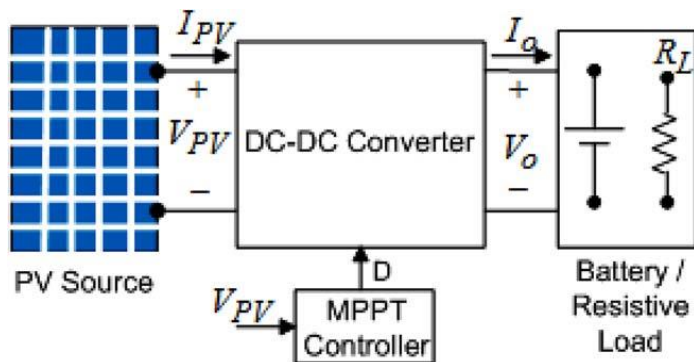

Fig -1: Block diagram of PV system with MPPT control.

MPPT controller is progressing to extract the obtainable most power from the PV module or array regardless of the insolation (G) and temperature (T) variations. If the load is directly connected to the PV module it's impossible to operate at peak point because of ohmic resistance mismatch. Converter facilitates to transfer most power from the PV module to the load by dynamical the duty cycle generated by the MPPT controller and a general block diagram of the PV system with MPPT controller is shown in Fig. 1.

2. VOLTAGE SENSOR BASED FOR MPPT FOR MULTILEVEL INVERTER

Multilevel inverters are the alternative for medium voltage applications. Within the inverters types there are

symmetric and asymmetric topologies. The asymmetric inverters have different DC voltage values. The most common topology is when the different cells are implemented in cascade arrangement, where the DC voltage are in multiples of 3, obtaining an AC voltage with $3n = 27$ levels ($n = 3$ cascaded inverters).

This topology provides a load voltage with low harmonic content, THD < 3%. However, this high quality voltage has a non-negligible drawback, which is the presence of regeneration in some of the inverters, independent of load type [1]. This phenomenon is due to the modulation technique (Nearest Level Modulation) used by this inverter. In this work, the asymmetric 15 level inverter is presented. This inverter is designed to avoid the regeneration problem-power flow from the load to the inverter-in some of the power cells. This is achieved by obtaining the firing angles associated with the power cells considering a minimum load voltage THD. Finally, a power flow analysis is accomplished and simulated results show the feasibility of this approach. Fig.2 shows the proposed inverter fed to 3-phase a.c load and Fig.3 shows the simplified diagram with three stage power circuit.

The most commonly used multilevel topology is the diode clamped inverter, in which the diode issued as the clamping device to clamp the dc bus voltage so as to achieve steps in the output voltage. A three-level diode clamped inverter consists of two pairs of switches and two diodes. Each switch pairs works in complimentary mode and the diodes used to provide access to mid-point voltage.

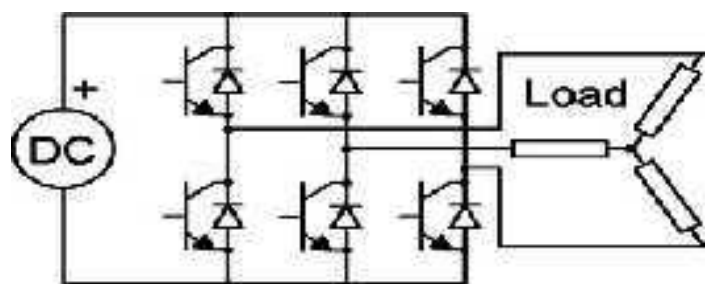

Fig -2: Proposed inverter fed to 3-phase a.c load.

In a three-level inverter each of the three phases of the inverter shares a common dc bus, which has been subdivided by two capacitors into three levels. The DC bus voltage is split into three voltage levels by using two series connections of DC capacitors, C1 and C2.

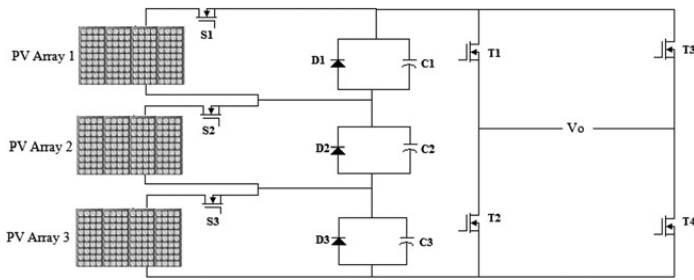

Fig -3: Three Stage Power circuit.

The voltage stress across each switching device is limited to V_{dc} through the clamping diodes D_{c1} and D_{c2} . It is assumed that the total dc link voltage is V_{dc} and midpoint is regulated at half of the dc link voltage, the voltage across each capacitor is

$$V_{dc}/2 (V_{c1}=V_{c2}=V_{dc}/2) \quad (1)$$

Level	S1	S2	S3	T1	T2	T3	T4	V_o
0	0	0	0	0	0	0	0	0
1	1	0	0	1	0	0	1	48
2	0	1	0	1	0	0	1	96
3	1	1	0	1	0	0	1	144
4	0	0	1	1	0	0	1	192
5	1	0	1	1	0	0	1	240
6	0	1	1	1	0	0	1	288
7	1	1	1	1	0	0	1	336

Fig -4: Switching Sequence of 15 Level Inverter Circuit

MPPT is very essential for the maximum power from the PV array. If we connect any load to the PV then in the result we will not get the proper output it is not get power point at the peak due to the mismatch of impedance as shown in Fig.5. Here duty cycle is generated from the MPPT controller.

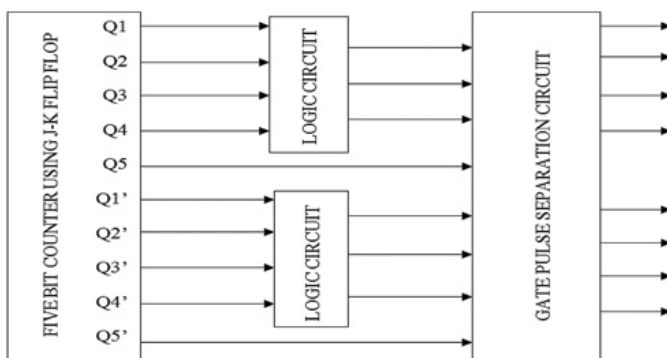

Fig -5: block diagram of proposed logic circuit.

Any number of levels can be achieved with this methodology by only adding the counters as accordance to the number of inverter stages and control logic functions.

2.1 Case 1: For Resistive Load

Using output and input voltage relation

$$\eta = \frac{V_o I_o}{V_{PV} I_{PV}} \quad (2)$$

$$\eta = \frac{V_o I_o}{\frac{(V_{PV})^2}{R_{eq}}} = \left(\frac{V_o}{V_{PV}} \right)^2 \frac{R_{eq}}{R_L} = \left(\frac{D}{1-D} \right)^2 \frac{R_{eq}}{R_L}$$

Where V_{PV} and I_{PV} are the PV voltage and current, separately. The comparable info resistance R_{eq} of the converter can be gotten from (2) as takes after:

$$R_{eq} = \eta \left(\frac{1-D}{D} \right)^2 R_L \quad (3)$$

By utilizing (3), the yield control from the PV module, which is input energy to the inverter, is given by,

$$P = \frac{(V_{PV})^2}{R_{eq}} = \frac{(V_{PV})^2}{\eta R_L} \left(\frac{D}{1-D} \right)^2 \quad (4)$$

Both P and square foundation of energy (P^*) have the greatest incentive at a similar obligation cycle (D). By considering the square base of energy (P^*) to get a target work for following the most extreme power, the accompanying condition can be gotten:

$$P^* = \sqrt{P} = \frac{V_{PV}}{\sqrt{\eta R_L}} \left(\frac{D}{1-D} \right) \quad (5)$$

At MPP, the incline of the P^* bend is zero (i.e., $dP^*/dD = 0$), and it can be assessed as

$$\frac{dP^*}{dD} = \left(V_{PV} \frac{1}{(1-D)^2} + \left(\frac{D}{1-D} \right) \frac{dV_{PV}}{dD} \right) \frac{1}{\sqrt{\eta R_L}} = 0 \quad (6)$$

$$\frac{dP^*}{dD} = \left(\frac{V_{PV} dD + D(1-D) dV_{PV}}{(1-D)^2 dD} \right) \frac{1}{\sqrt{\eta R_L}} = 0 \quad (7)$$

By evaluating dP^*/dD using (7) at MPP, the objective function Q can be obtained as follows:

$$Q = D(1-D) dV_{PV} + V_{PV} dD \begin{cases} = 0, \text{ at MPP} \\ > 0, \text{ on left of MPP} \\ < 0, \text{ on right of MPP.} \end{cases} \quad (8)$$

Consequently, contingent upon the indication of Q, the MPPT calculation chooses whether to increment or decline the obligation cycle, and the comparing Q-D attributes.

2.1 Case 2: Versatile Voltage-Sensor-Based MPPT with Variable Scaling Factor

In this paper, a versatile voltage-sensor-based MPPT with variable scaling component is proposed to lessen the following time what's more, power misfortune in consistent state. The present and past cycle estimations of PV voltage an obligation cycle of the converter are indicated by $V_{pv}(k)$, $V_{pv}(k-1)$, $D(k)$, and $D(k-1)$, individually. The adjustments in the voltage and obligation cycle from the present emphasis to the following cycle are characterized as takes after:

$$dV_{PV} = V_{PV(K)} + V_{PV(K-1)} \tag{9}$$

$$dD = d_1 - D_k \tag{10}$$

The area of the working point is chosen by assessing Q what's more, contingent upon the indication of Q; the obligation cycle is augmented or, then again decremented by ΔD as given in (10). On the off chance that Q is certain, then the obligation cycle is augmented by ΔD , and if Q is negative, then the obligation cycle is decremented by ΔD . As ΔD is straight forwardly utilized in altering the obligation cycle, the controller is basic and simple to actualize with a microcontroller. In this manner,

$$D_{(k+1)} = D_{(k)} \pm \Delta D \tag{11}$$

The value of Q is large in start-up and during insolation change, whereas it is small in the steady state. Thus, a fixed scaling factor cannot satisfy the requirement of MPPT controller in different conditions. Hence, in this proposed algorithm, two different scaling factors M1 and M2 are considered to optimally vary the perturbation step size ΔD , which has been defined as a linear function of Q by,

$$\Delta D = M_1 Q \tag{12}$$

The scaling component M_i ($i = 1, 2$) assumes a critical part in a versatile MPPT strategy; hence, it ought to be picked wisely to build the pinnacle control following productivity. The scaling factor M1 is lessened the following time in startup what's more, for an expansive change in insolation. The scaling component M2 is lessened the power misfortune in the relentless state. In this way, the proposed versatile MPPT technique enhances both the transient furthermore, relentless state execution.

The scaling variable either M1 or M2 is produced ΔD relying upon the estimation of Q concerning a predefined limit estimation of the goal work, i.e., Q_{th} , as appeared in the pseudo code of the calculation. By considering an upper restrict (ΔD_{max}) of 10% and a lower confine

(ΔD_{min}) of 0.5% to bother step measure (ΔD), the scaling variables M1 and M2 ought to comply (13) and (14), individually, with a specific end goal to ensure the union of the MPPT calculation. The estimation of ΔD will fluctuate amongst ΔD_{min} and ΔD_{max} , as given in (15). In this manner,

$$M_1 Q \leq \Delta D_{max} \tag{13}$$

$$M_2 Q > \Delta D_{min} \tag{14}$$

$$\Delta D = \begin{cases} \Delta D_{max}, & \text{if } \Delta D > \Delta D_{max} \\ \Delta D, & \text{if } \Delta D_{max} \leq \Delta D \leq \Delta D_{min} \\ \Delta D_{min}, & \text{if } \Delta D < \Delta D_{min} \end{cases} \tag{15}$$

A: Steady State Analysis

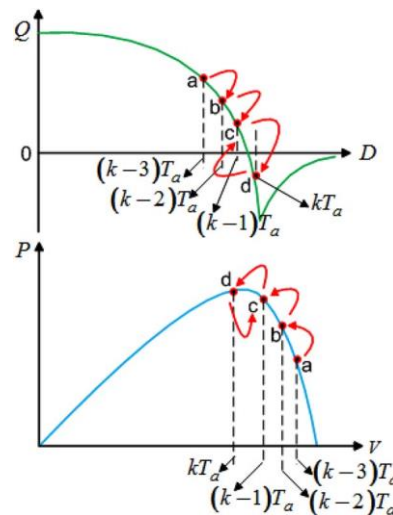

Fig -6: Movement of the Q-D characteristic along with the P-V characteristic.

In fig.6 we can see the movements of the P-V and Q-D Characteristic. In steady state the operating points which are moves in two levels.

B: Steady State Power Loss Evaluation

The two-level operation of the voltage-sensor-based MPPT algorithm reduces the voltage oscillations around the MPP, resulting in power loss reduction compared with three-level MPPT algorithms such as P&O and IncCond.

C. Drift Analysis

The movement of the operational purpose in an exceedingly wrong direction for a modification in insolation is termed drift, and this impact is severe in case of speedy modification in insolation [19]–[22]. The drift downside occurs just in case of modification in insolation with P&O and InCond methods, and it's well self-addressed within the literature [18]–[20], [22], however the drift analysis for voltage-sensor- based MPPT will not exist within the

literature. The drift analysis with this methodology can be examined by evaluating the modification in operational voltage VPV and therefore the objective perform letter for a modification in isolation.

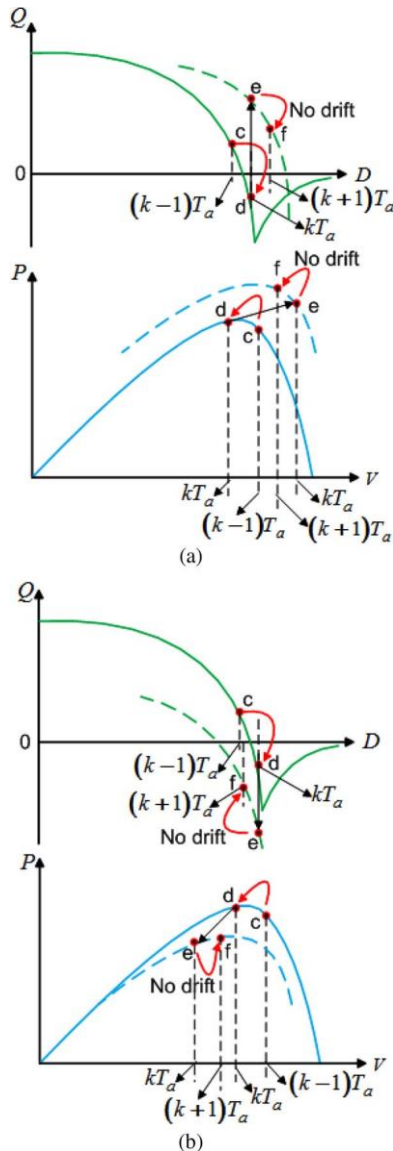

Fig -7: Drift analysis with Q-D and P-V characteristics (a) for a step increase in insolation and (b) for a step decrease in insolation.

3. SIMULATION

Our simulation model is completed within the MATLAB 2010 software. From exploitation library we have a tendency to area unit begin the simulation. Maximum electrical parts area unit found within the Sim-power system of the MATLAB. For the device we have a tendency to use MOSFETS instead of the IGBT as a result of its shift amount is extremely low. To create this device tendency to we tend to take all element ten and connect them as per the given device in our paper as shown within the on top of

model generator block is use and it's connected to generator to get the pulse. Likewise as we've got to point out the results, for showing results scope is used. We are able to see the results because the kind of waveform. Powergui block is used to supply the equivalent circuits to the planned device. Fig. seven is nothing however the example of the specified output. An adaptive MPPT design with multilevel inverter circuit is shown in fig. 8. A) & fig. 8. B). Fig. 8. C) Shows the final MPPT output while comparison of drift analysis of fixed and adaptive MPPT method is shown in fig. 8.D). From fig. 8. (E) We are able to see the level and once we check the THD as shown in refer the fig. 8 (F) thus from the figure seven we have a tendency to assume our output and that we can prove these results by applying the planned ways.

Fig -8 (A): MPPT with Multilevel Inverter Circuit

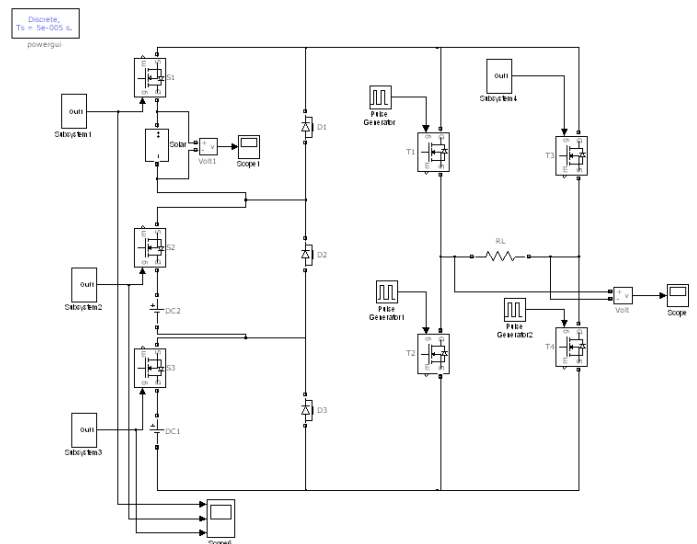

Fig -8 (B): Adaptive MPPT Design

```

1 function d1 = MPPT(Vnew,Vold,Inew,Iold,Pnew,Pold,dD)
2 %V=Input Voltage; vi=New Voltage; I=Input current; a=New current;d=Calculated duty cycle
3 Vnew = 6;
4 Inew = 1.9;
5 d1 = 0.5;
6 Dk=dD-(dD+0.5)/(Vnew/Vold);
7 dV=Vnew-Vold;
8 dP=Pnew-Pold;
9 %dI=Inew-Iold;
10 %Pnew=Vnew*Inew;
11 %Pold=Vold*Iold;
12 if (dP/dV==0)
13     dD=d1-Dk;
14 else if (dP/dV>0)
15     % p < 0 Method
16     if (dP>0)
17         if (dV>0)
18             d1=d1+Dk;
19         else
20             d1=d1-Dk;
21         end
22     else
23         if (dV<0)
24             d1=d1-Dk;
25         else
26             d1=d1+Dk;
27         end
28     end
29     d1=Dk;
30 end
31 d1=Dk+1;
32 end
33

```

Fig-8 (C): MPPT Output

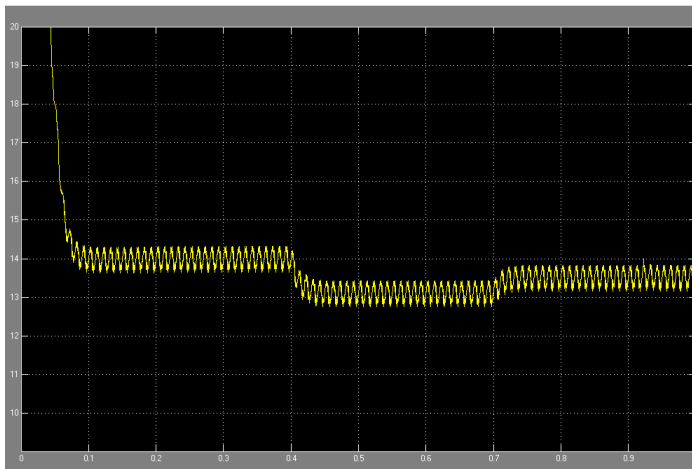

Fig-8 (F): THD calculation of proposed 3-phase, 15-level inverter using powergui FFT Analysis tool.

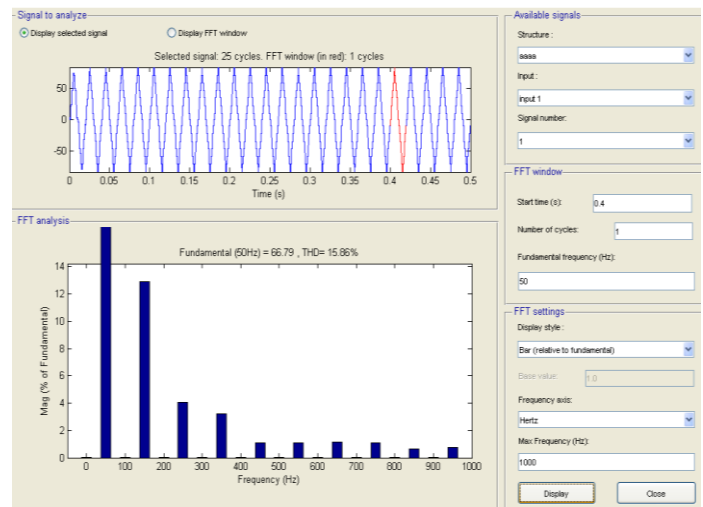

Fig-8 (D): Comparison of drift analysis of Fixed & Adaptive MPPT Method

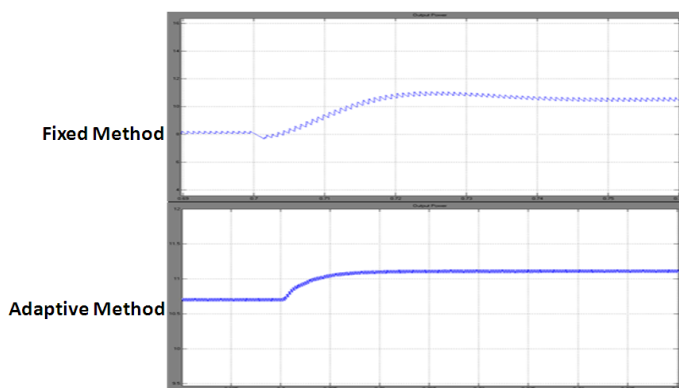
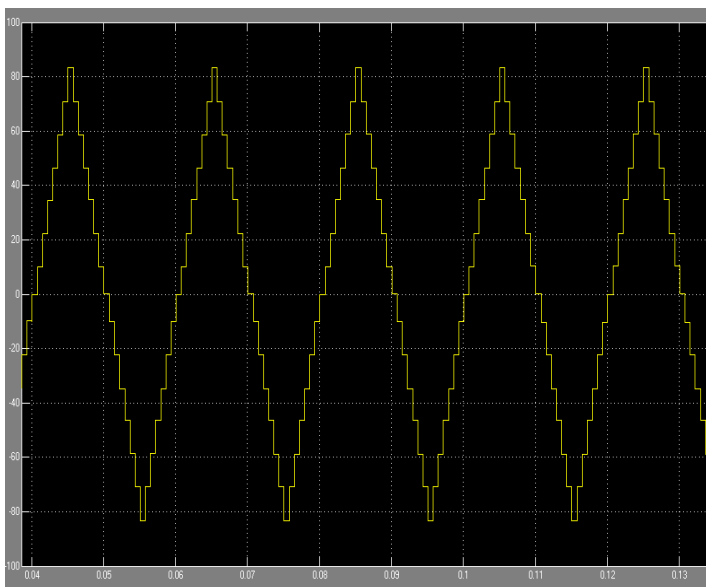

Fig-8 (E): The 3-phase, 15-level output voltage waveform from the proposed inverter.



4. CONCLUSION

In this paper, MPPT algorithm with variable scaling factor by considering direct duty cycle management methodology for multilevel inverter has been implemented. The projected system is designed, and also the practicality of MPPT management has been proved. The simulation and experimental results proves that the planned system is ready to track the most power from the PV module; furthermore, the steady-state two-level operation and also the drift-free phenomena are the deserves of this tracking algorithm. Hence, this technique improves the efficiency of the PV system and reduces power loss in steady state. From the results obtained, it's detected that, with a well-designed system, as well as a correct converter and an economical MPPT algorithm, the MPPT will be developed with less quality and reduced value.

REFERENCES

- 1] M. G. Villalva, J. R. Gazoli, and E. R. Filho, "Comprehensive approach to modeling and simulation of photovoltaic arrays," IEEE Trans. Power Electron. vol. 24, no. 5, pp. 1198–1208, May 2009.
- 2] D. B. Snyman and W. Swiegers, "Integrated photovoltaic maximum power point tracking converter," IEEE Trans. Ind. Electron., vol. 44, no. 6, pp. 769–773, Dec. 1997.
- 3] M. A. S. Masoum, H. Dehbonei, and E. F. Fuchs, "Theoretical and experimental analyses of photovoltaic systems with voltage and current-based maximum power-point tracking," IEEE Trans. Energy Convers., vol. 17, no. 4, pp. 514–522, Dec. 2002.

4] .F. Liu, S. Duan, B. Liu, and Y. Kang, "A variable step size INC MPPT method for PV systems," IEEE Trans. Ind. Electron., vol. 55, no. 7, pp. 2622–2628, Jul. 2008.

5] A. Safari and S. Mekhilef, "Simulation and hardware implementation of incremental conductance MPPT with direct control method using Cuk converter," IEEE Trans. Ind. Electron., vol. 58, no. 4, pp. 1154–1161, Apr. 2011.

6] K. S. Tey and S. Mekhilef, "Modified incremental conductance algorithm for photovoltaic system under partial shading conditions and load variation," IEEE Trans. Ind. Electron., vol. 61, no. 10, pp. 5384–5392, Oct. 2014.

7] Q. Mei, M. Shan, L. Liu, and J. M. Guerrero, "A novel improved variable step-size incremental- resistance MPPT method for PV systems," IEEE Trans. Ind. Electron., vol. 58, no. 6, pp. 2427–2434, Jun. 2011.

8] P. L. Chapman, and P. Midya, "Dynamic maximum power point tracking of photovoltaic arrays using ripple correlation control," IEEE Trans. Power Electron., vol. 21, no. 5, pp. 1282– 1291, Sep. 2006.

9] T. Wu, C. Chang, and Y. Chen, "A fuzzy-logiccontrolled single-stage converter for PV-powered lighting system applications," IEEE Trans. Ind. Electron., vol. 47, no. 2, pp. 287–296, Apr. 2000.

10] Syafaruddin, E. Karatepe, and T. Hiyama, "Artificial neural network-polar coordinated fuzzy controller based maximum power point tracking control under partially shaded conditions," IET