

Seismic Analysis on bare frame, infilled frame and soft story RC framed buildings

Charan chikka javaregowda k s¹, Mahadev prasad²

¹M.Tech, Department of civil engineering, The Oxford College of Engineering & Technology, Bangalore, Karnataka, India

² Assistance Professor, Department of civil engineering, The Oxford College of Engineering & Technology, Bangalore, Karnataka, India

Abstract -Strength and stiffness are the main requirement for the any structural building. But know a days bare frames are most common in the all over the country. In bare frame design neglecting the masonry loads. Masonry is the most commonly used material in the buildings. Masonry infills are used to partition walls. In this paper we study the behavior of bare frame structure, infilled structure and soft story structure.

Comparing the results of base shear, story drift, natural time and natural frequency.

Key Words: infilled frame, bare frame, open one story frame, open two story frame, RC frame, diagonal strut, seismic analysis, base shear, time period, natural frequency, story drift.

1.INTRODUCTION

In multi-storey buildings, A large number of buildings in India are RC framed structures are constructed with masonry infills or brick infills for functional and architectural reasons. The masonry infills reinforced concrete frames buildings are commonly constructed for commercial, residential and industrial buildings in seismic regions. Masonry infills stiffness contribution are generally ignored in practice and masonry infills are normally considered as architectural [non-structural] elements. The masonry infills are typically consists of brick or concrete blocks constructed between columns and beams of reinforced concrete frame.

Infilled frames are composite structure made by the combination of infill wall and moment resisting plan frame. The infill are used as interior partition walls ad external walls. And also infills are protecting from outside environment to the building to our requirements. Infill walls are tend to contact with the beam and column when the structure is subjected to seismic load, and also exhibit-dissipation characteristics under lateral loads. The presence of masonry infill walls has a affect on the lateral load of a reinforced concrete frame building, increasing the structural stiffness and structural strength. Clearly designed infills can increase the lateral resistance, overall strength and energy

dissipation of structure. An infill wall reduce the bending moment in the frame and lateral deflections there fore decreasing the probability of collapse and also reduce the displacement.

Nowadays reinforced concrete frames are most common in building construction practice around the globe. The vertical gap that is created by the beams and columns are normally filled by the masonry or brick and it is known as brick infill walls or panels. These walls are built from brunt brick in cement mortar. These walls are generally of 230 to 115 mm thick. For the functional requirements the openings is provided in the walls for doors, windows and ventilators etc. The one more important reason for the use of brick or masonry infills in structure is the ease with which can be constructed that is it generally contains the locally obtained materials and also it has the heat insulating and good sound proofing properties those results in the greater comfort for the buildings.

Masonry walls are the non structural part of building or structure. Masonry walls are provided strength, stability and durability to the RC frame structure and also helps to maintain the indoor and outdoor temperature. It separates a building from outside world.

Masonry is the world used for construction with mortar as a binding material with individual units of bricks, tiles etc. mortar is a mixture of binding materials can be cement, lime soil or any other. The durability and strength of masonry wall construction depends on the type and quality of materials used and workmanship.

1.1 LITERATURE REVIEW

Numerous studies have made on the seismic analysis of RC frame structure with and without infill walls. As well frame with open first story, frame without open first story, bare frame. A brief review of the available information studies are presented below.

V.K.R. Kodur, M.A. Erki and J.H.P. Quenneville : Considerd a RC frame building model for the analysis. These frames were analysis for three cases they are Bare frames, infilled frame, infilled frame with opening frame. the result they considered

that the base shear and natural frequency of infilled frame is more as compare to infilled frame with opening and bare frame. Time period of infilled frame is less as compared to infill frame with openings and bare frame.

Jaswat N.Arlekar, Sudhir K.Jain and C.V.R. Murty : Analyzed using ETABS software. For the buildings with masonry infill walls and building with no walls in the ground story and bare frame building model. Static and dynamic analysis of building models are used. The result obtained from the ETABS for natural period is not tally with natural period obtained from the expression of the load IS 1893-1984. The natural period of soft story frame and bare frame buildings is more compare to natural period of infilled frame.

Mehmet Metinkose : Analysed the various reinforced concrete frames models they are

- 1) Frame with open first story, 2) Bare frame, 3) Frame without open first story.

Based on the different results obtained from the different models, it was seen that the height of building and number of floors was the primary parameters affecting the fundamental period of building. The fundamental period of frame with open first story and bare frame is more then the fundamental period of frame without open first story.

P.M. Pradhan, P.L. Pradhan, and R.K. Maske : Highlighted the need of knowledge on masonry infilled frame. The infill contributes the stiffening and strengthening of the frames. The infill can increases the stiffness of the frame 4 to 20 times (referring to number of literature).

B. Srinivas and B.K. Raghu Prasad : Concluded that effect of masonry infill wall on dynamic behavior of structure. They discussed for different type frame models they are, * RC masonry infilled frame * soft first story frame * bare frame model.

According to IS 1893 code designed Diagonal strut method was used for modeling the masonry infill walls. To study the response behavior of the building nonlinear static and nonlinear dynamic analysis was performed.

Authors concluded the presence of infill reduce the lateral forces and increases the overall strength of the building. The story drift decrees due to the presence of masonry infill walls in the infilled frame.

Arlekar, Jain and murty (1997) : Studied the importance of the presence of the soft first story or open first story in the analysis of the building.

Lee and Woo (2002) : Concluded the effect of masonry infill on the seismic performance of low rise reinforced concrete frame. Authors investigated that the effect of masonry infill are to be considered for the reinforced concrete frame buildings.

Haque and Khan (2008) : Discussed the behavior of the columns at the bottom level of the reinforced concrete multistoried buildings with soft ground floor subjected to seismic loading. The structural behavior of masonry infills of upper floors has been considered by modeling them as diagonal strut.

Dolsek and Fajfar (2008) : Illustrated the effect of masonry infill on the seismic response of a multistory reinforced concrete frame using response spectrum analysis. From the analysis results author concluded that the masonry infill can completely change they throughout behavior of the structure.

Kaushik, Ravi and Jain (2009) : Studied the some properties for masonry infilled reinforced concrete frame building with an soft storey for the effectiveness in increasing the performance during earthquake.

P.G.Asteries : Studied the lateral stiffness of brick masonry infilled walls frame with different size of the opening in the minimizing or reduction of the brick masonry infilled frames stiffness has been investigated.

Kasim Armagan Kormaz : Investigated reinforced concrete frame structure with various amount of brick masonry infill walls considered to diagonal approach is adopted for modeling masonry infill walls and investigate the affect of infill walls.

Polykov (1956) : The study of the behaviour of masonry infills suggested that the frames and infills dispartate at two compression corners. He invented the concept of equivalent diagonal strut and proposed that transformation of stresses from the frame to infill occurs only in the compression zone of the infill.

Holmes (1961) : concluded that the infills can be changed or replaced by diagonal strut that is pin jointed at corners and is same thickness and materials and its width is equal to one third of the diagonal.

2 METHODOLOGY OF SYSTEM

The present work is focusing on the seismic analysis of bare frame structure, infilled structure, and soft story structure. Using response spectrum. For G+14 story building with the spacing between the two frame is 6m in both direction.

2.1 Objective:

- The frame structure are used for the analysis.
- Reinforced concrete frame with bare frame structure, infilled structure, soft story structure are analyzed by response spectrum.
- ETABS 2016 is used for the analysis
- Comparison of results for different structure.

2.2 Methodology :

- To analyses the seismic behavior of G+14 RC bare frame.
- To analyses the seismic behavior of G+14 RC infill frame.
- To analyses the seismic behavior of G+14 RC one story opening at ground.
- To analyses the seismic behavior of G+14 RC two story opening at ground.

2.3 Analyzing the data:

Following data are used in the model

- Seismic zone :3
- Number of stories : 15
- Floor height :3.5m
- Depth of slab : 150mm
- Size of beam : (230x450)mm
- Size of column : (230x600)mm
- Spacing between frame : 6m
- Live load on floor :3kn/m²
- Floor finish :0.6kn/m²
- Terrace water proof : 1.5 kn/m²
- Materials M20 concrete, Fe 415 steel
- Wall thickness : 230 mm
- Density of concrete :25kn/m³
- Density of infill : 20kn/m³
- Type of soil : medium
- Damping of structure : 5 %
- Response spectrum : as per IS 1893(part-1):2002

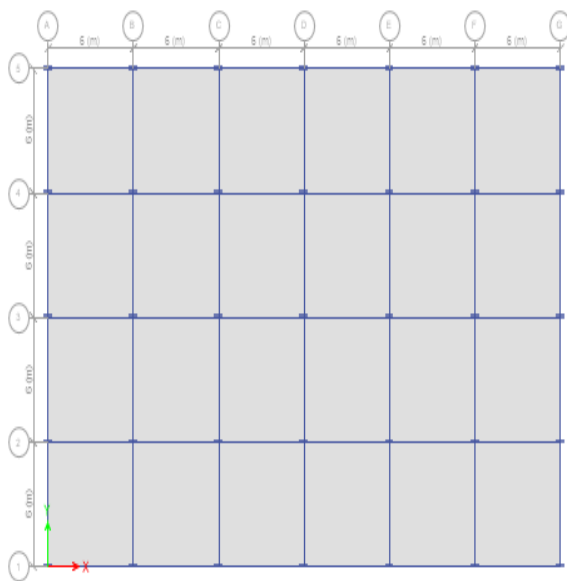
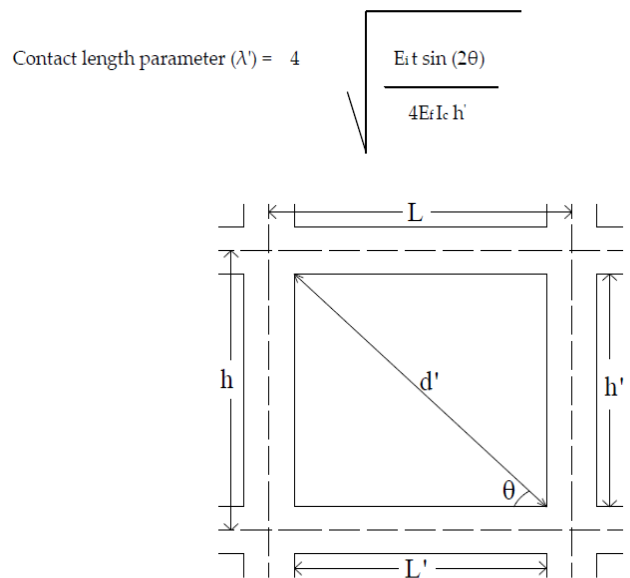

Fig-1:Building plan (ETABS model)



d'=diagonal length of strut
 t=thickness of infill wall
 Ic=moment of inertia of column
 h=column height between beams
 h'=height of infill wall
 l'=length of infill wall
 l=beam length between beams
 Ei=modulus of elasticity of infill materials
 Ef=modulus of elasticity of frame materials.

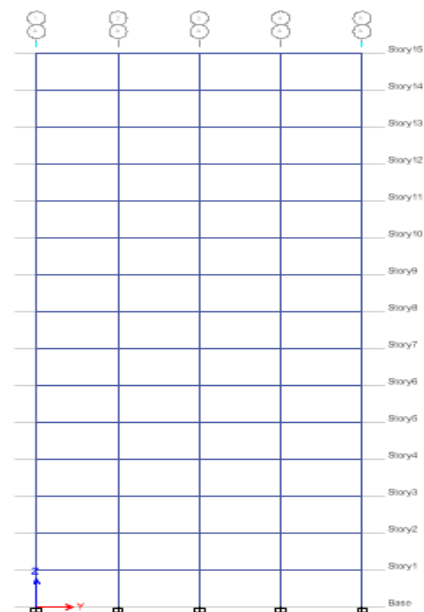

Fig-2: Bare frame

w = 0.175 (λ'h)-0.4d'

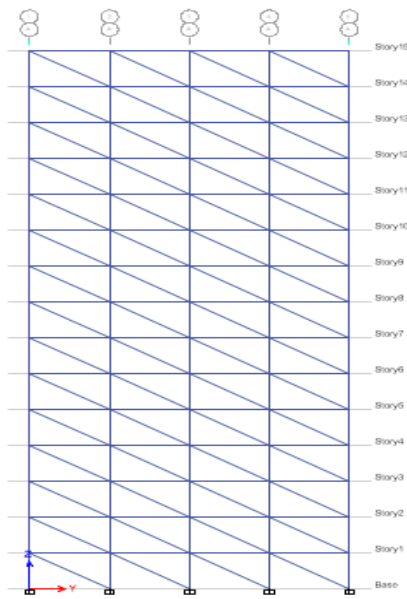

Fig-3: Infilled frame

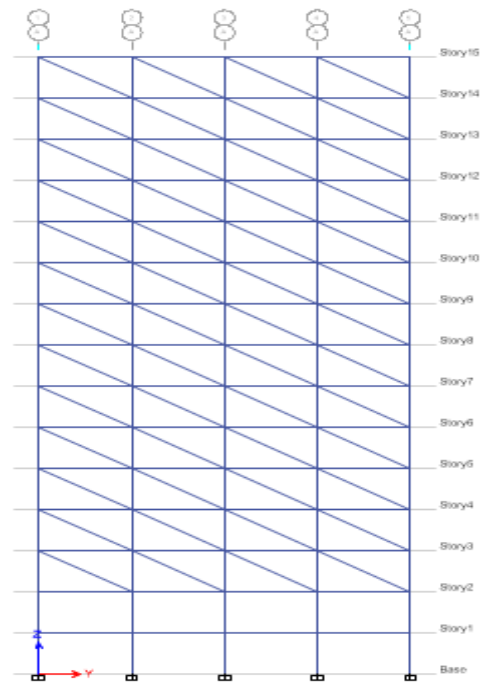

Fig-5: Open two story frame

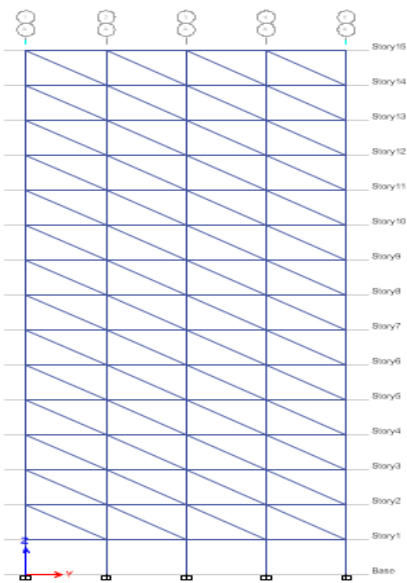

Fig-4: Open one story frame

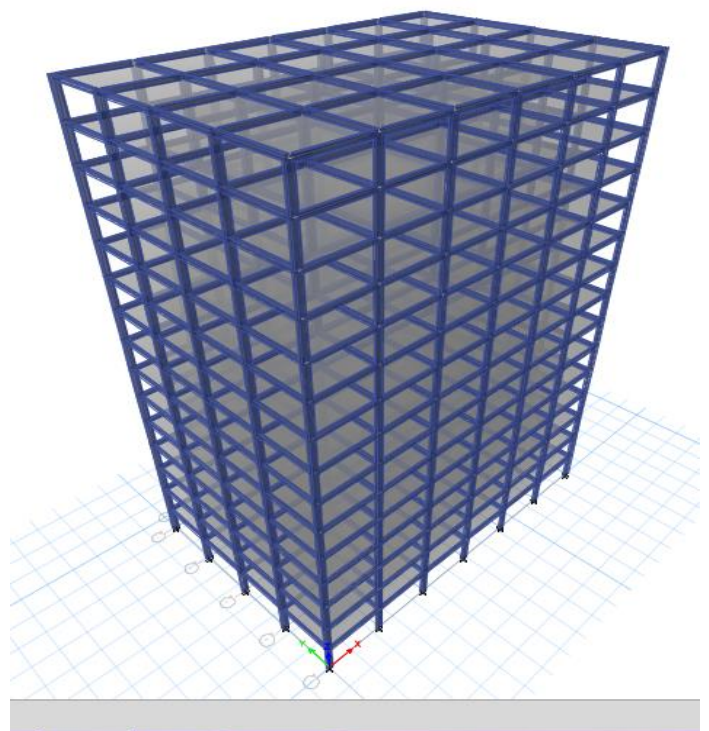

Fig-6: 3D Bare frame building model

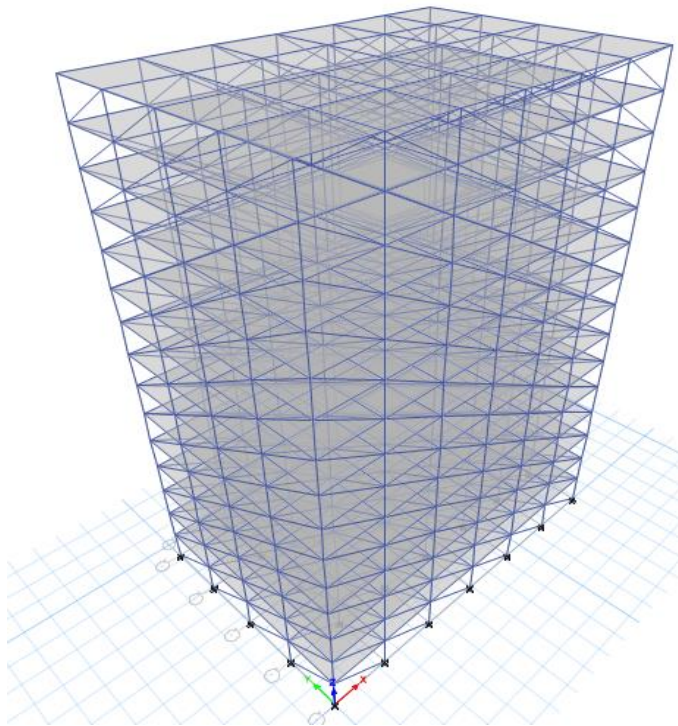

Fig-7: 3D infilled frame building model

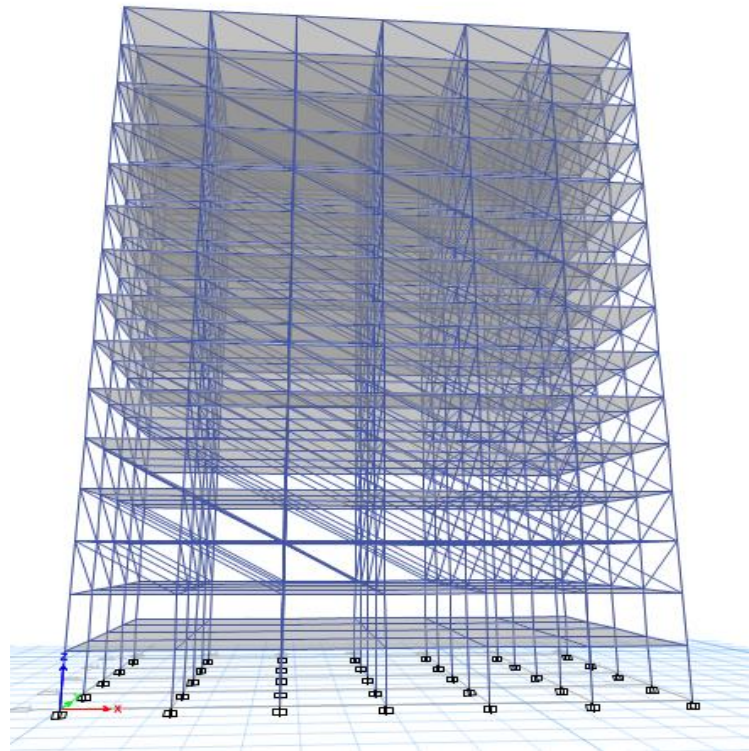

Fig-9: 3D bottom two open story frame building model

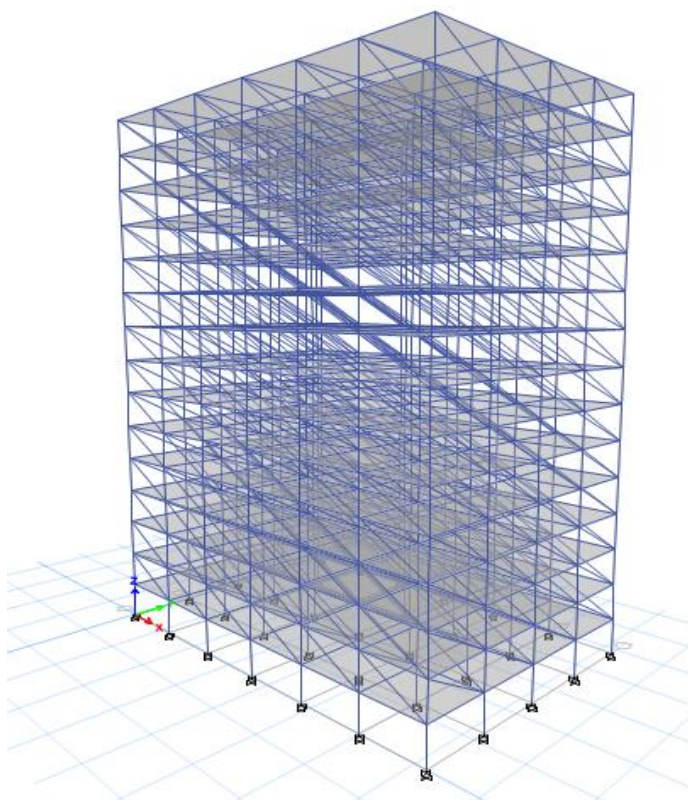

Fig-8: 3D open first story frame building model

3 RESULT AND DISCUSSION:

The seismic analysis on the bare frame, infilled frame and soft story building results are discussed below. And above analysis as done by using the ETABS software. The parameters considered are story drift, natural frequency, time period, base shear.

Comparison of dynamic characteristics of frames with

3.1 BARE SHEAR:

Table-1: variation in base shear for different RC buildings.

Base shear Vb(KN)	Type of structure
728.559	Bare frame
2816.02	Infilled frame
2322.52	Open one story
1639.11	Open two story

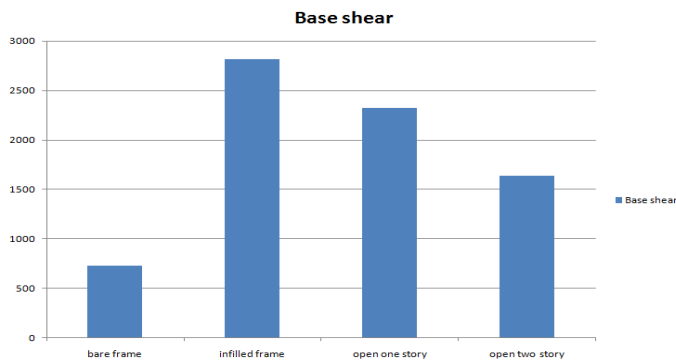

Chart-1: variation in base shear for different RC buildings.

3.2 NATURAL FREQUENCY:

Table-2: variation in natural frequency for different RC buildings.

Natural frequency W(Hz)	Type of structure
0.208	Bare frame
9.691	Infilled frame
3.8094	Open one story
2.4812	Open two story

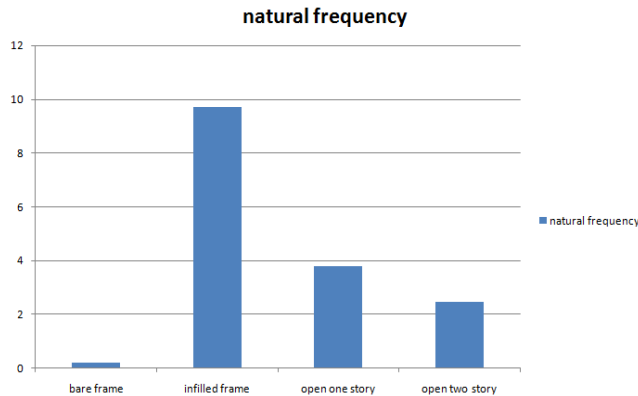

Chart-2: variation in natural frequency for different RC buildings.

3.3 TIME PERIOD :

Table-3: variation in time period for different RC buildings.

Time period T(sec)	Type of structure
4.802	Bare frame
0.648	Infilled frame
1.649	Open one story
2.531	Open two story

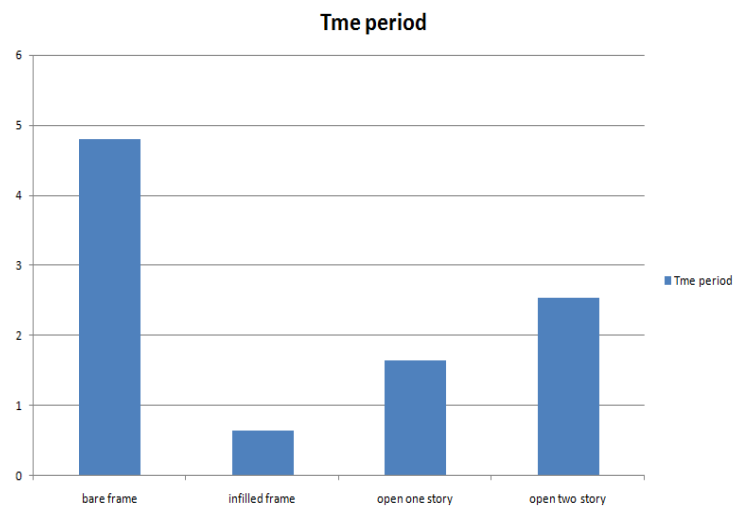

Chart-3: variation in time period for different RC buildings.

3.4 CONCLUSION:

This analysis is done for the soft story like open one story, open two story, infilled frame and bare frame structure. We concluded that seismic analysis on reinforced concrete frame structure has been done that includes soft story, infilled frame and bare frame following conclusion are obtained.

- Equivalent diagonal strut method is used for the modeling of the infill wall, effectively this method is used for the this seismic analysis of reinforced concrete frame structure.
- From the obtained studied graph we concluded that some important points.
- For the earthquake force infilled frame is more effective compare to the bare frame.
- For earthquake force infilled frame structures are more resist than bare frame.
- For the large extent infill structures are more stiffness and strength compare to other type of structures.
- Story drift in infills frame structure is less compare to the bare frame there fore bare frame structure leads to collapse during earthquake force.
- Compare to the bare frame and open one story frame structure, bare frame structure gives more effective than open one story. Bare frame gives more stiffness and strength compare to the open one story . because in open one story there is no infill at ground floor.
- Story drift in bare frame is less compare to the open one story. There fore structure leads to collapse during earthquake force.
- Compare to the open one story frame structure and open two story frame structure, open one story frame gives more effective than open two story,

open one story is more stiffness and strength compare to the open two story.

- Story drift in open one story frame is less compare to the two story frame structure.
- There fore compare to all frame structure infilled frame structure is strength and stiffness.

Considering dynamic characteristics parameters are,

- Time period: time period is more in the bare frame compare to the other frame like infilled and soft story frames.
- Natural frequency: natural frequency is more less in the bare frame compare to the infilled and soft story frames.
- Base shear: base shear is more in the infilled frame compare to the bare and other structure.

Studying the above all parameters we concluded that infilled frames are stiffer and strength compare to other frame structure.

3.5 REFERENCE:

1. ETABS – 2016 integrated building design software manual, CSI, USA.
2. C,V,R,Murthy and Diptesh, “seismic design of reinforced concrete framed buildings for bricks masonry infilled frames, the Indian concrete journal (2004).
3. P, G, Asteris, “ bricks masonry infilled plane frames for lateral stiffness” ASCE (2003), journal of structural engineering.
4. Mulgund G,V “ seismic analysis of reinforced concrete frame buildings with brick masonry infills “ international journal of technologies and advanced engineering, vol no 2.
5. B,K Raghu and B. srinivas “ the influence of masonry in reinforced concrete multistory building to near fault ground motions” journals of international association for bridge and structural engineering (IABSE) 2009.
6. R,K. Masonary, P.M.Pradhan, P.L.Pradhan engineering and technology. Vol 8 february 2012.
7. C.V.R.Murthy, jaswant N.Arlekar, and sudhir K. jain, “seismic behaviour of reinforced concrete framed building structure with soft story 1997 new delhi.
8. Mehunet Metin Kosel “ parameters affecting the reinforced concrete building with infill wall engineering structure 31 (2009).
9. M.A.Erki, J.H.P. Quenneville and V.K.R. kodur, “ seismic analysis of infilled frames “ journal of structural engineering vol 25, july 1998.
10. Abbic B.liel and siamak satter “ seismic performance of reinforced concete frame structure with and without masonry infill walls “ university of Colorado, boulder.